



## Roof Mount Condenser **CR-410**

Our CR-410 high capacity roof mount condenser has been specifically engineered for use in commercial, light transit and school bus applications. This unit is the perfect combination of sleek, low profile European styling and American innovation. It has rugged Thermoplastic Polyolefin (TPO) cover shrouds and lightweight aluminum structure underneath, while allowing complete service access without cover removal. The highly adjustable mounting rails are designed to attach this unit to any exterior roof radius without leaving visually gaps between roof

and unit cover. MCC's innovative introduction of the roof mount condenser series to the North American bus market has given body builders the opportunity to free up skirt place for a variety of options including Compressed Natural Gas (CNG) tanks, wheelchair lifts and luggage compartments, while maintaining an aerodynamic exterior appearance to the vehicle. Our CR-410 roof mount condenser is the solution to road salt damage.



### Features

- Designed for use with R134a Refrigerant
- Utilizes Micro Channel Aluminum coil
- Thermoplastic Polyolefin (TPO) plastic cover
- Multiple unit configurations available
- Heavy-gauge aluminum frame
- Exterior visible sight glass and moisture indicator without cover removal
- O-Ring refrigerant connections
- Multiple available options and upgrades

### Benefits

- Lower cost, less weight, environmentally friendly
- Improved performance/ efficiency, reduced weight, reduced refrigerant charge, increased compressor life
- Durable, lightweight, flexible, UV resistant housing
- Allows unit to be used in various mounting applications and on various body types/ roof contours
- Corrosion resistant, lightweight base
- Ability to view for service/ maintenance purposes while saving time
- Reduced risk of refrigerant leaks
- Brushless fan motors, branch and winter guard kits just to name a few

# Rooftop Condenser **CR-410**

MCC Roof Mount Condensers

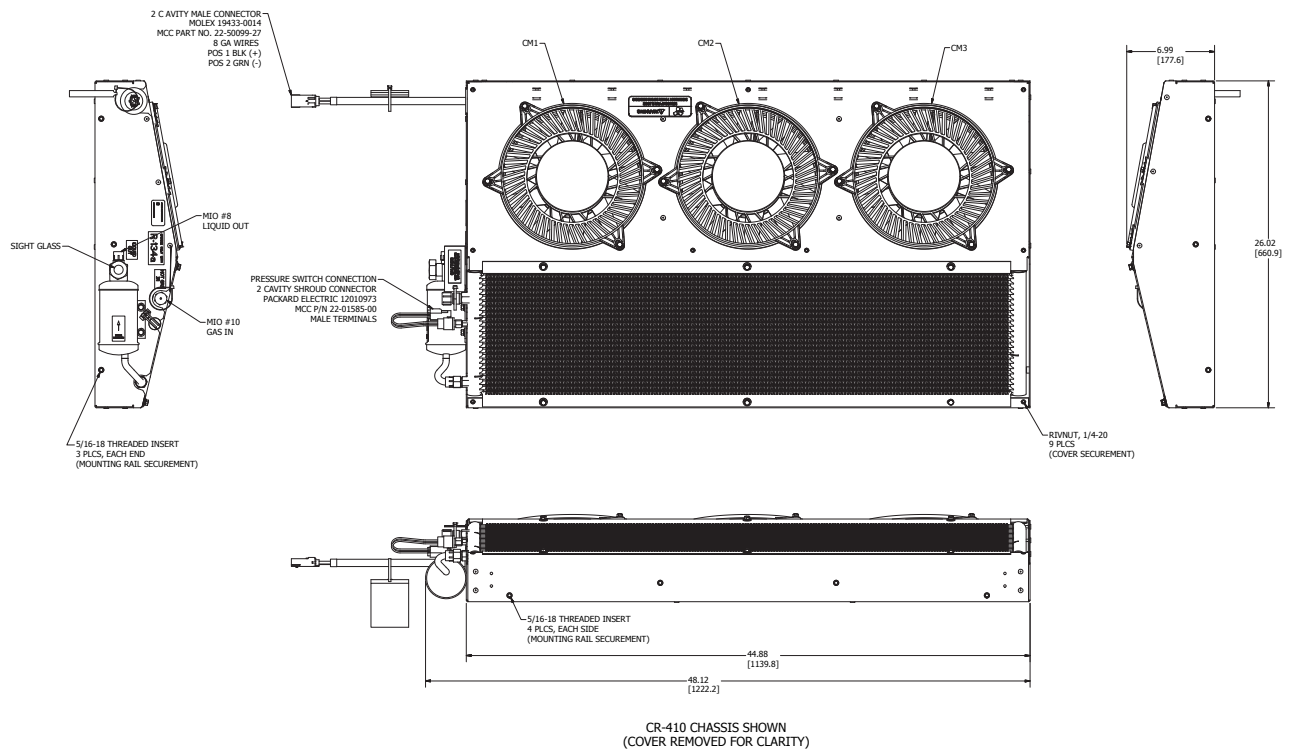

## Technical Data

Capacity	82000 Btu/hr (24 kW) IMACA <sup>[1]</sup> 57000 Btu/hr (16.7 kW) ARI <sup>[2]</sup>
Air flow	1680 CFM (2854 m <sup>3</sup> /hr)
Condenser coil	Advanced technology Micro Channel Heat Exchanger (MCHX)
Condenser fans	Low-profile, axial-flow type propeller fans balanced for quiet, vibration-free operation with finger guard.
Fan motors	Totally enclosed low profile permanent-magnet 4-pole brushed motors with extended life lubricated sealed bearings.
Max amperage requirement	21 amps @ 13.5 VDC; 11 amps @ 24 VDC
Safety controls	High refrigerant pressure cut-out 400 psi (28 bar), cut-in 300 psi (21 bar)
Filter dryer	16 in <sup>3</sup> (262 cm <sup>3</sup> )
Weight	58 lbs (26.3 kg)
Available color	White

[1] IMACA conditions: 100°F (38°C) / 90°F (32°C) / 50% RH

[2] ARI conditions: 95°F (35°C) / 80°F (27°C) / 50% RH

