



Compressor **Bock¹ FKX40 and FKX50 Bus Air Conditioning**

World class performance, compact and robust design

The product of extensive experience in the transport refrigeration and air conditioning market, the Bock FKX40 and FKX50 open drive compressor models offer world class performance and durability. The 4 cylinder FKX40 and

6 cylinder FKX50 are available in a variety of displacement levels and can be sized to meet a wide range of applications. The Bock Compressors offer many valued features sought after in the transport air conditioning market.

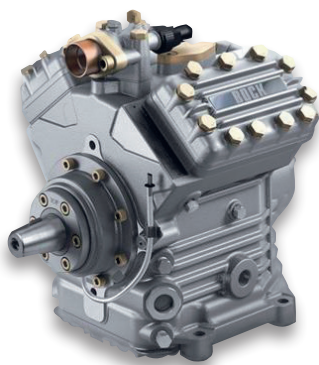

FKX40

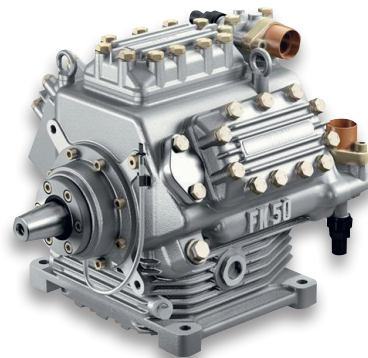

FKX50

Features

- High efficiency and reliable operation
- Lightweight and compact aluminum design
- Robust lubrication system and bearings
- Forced-feed lubrication
- Proven shaft seal designed for long life and ease of service
- Optimized for R134a
- Special K-valve plate optimized for air conditioning applications
- Practical drain through a feely accessible flexible tube (no dismantling of the clutch necessary)

Compressor Bock¹ FKX40 and FKX50 Bus Air Conditioning

MCC Compressors

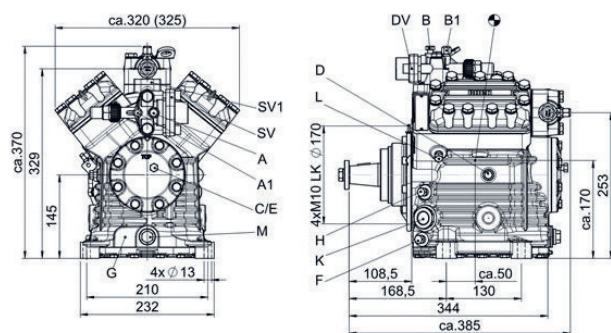

FKX40

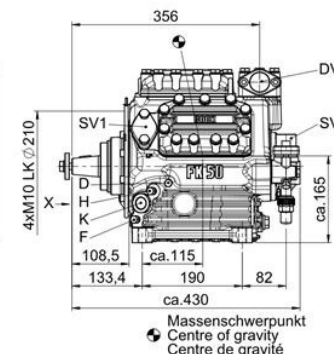
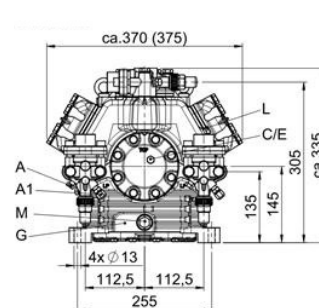

FKX50

Technical Data

	Bock ¹ FKX40	Bock ¹ FKX50
Rotation	CW/CCW	CW/CCW
Max speed	3500 rpm	3500 rpm
Clutch coil	24 VDC	24 VDC
Displacement	39.7 in ³ (650 cm ³ /rev)	50.7 in ³ (830 cm ³)
Number of cylinders	4	6
Refrigerant	R134a	R134a
Pulleys	2-SPB, 2 – 5 V	2-SPB, 2 – 5 V
Oil charge	67.6 oz (2000 cm ³)	67.6 oz (2000 cm ³)
Dimensions (L x W x H)	15.2" (386.08 mm) x 12.8" (325.12 mm) x 14.6" (370.84 mm)	16.9" (429.26 mm) x 14.8" (375.92 mm) x 13.2" (335.28 mm)
Weight (without clutch)	73 lbs (33 kg)	93 lbs (42 kg)

¹⁾ Bock Compressors are now part of the Global GEA Companies



Mobile Climate Control