



OPERATION AND SERVICE
for
68RM35-610 & Y13-R3501
MICROMAX / MCHX

T-356

REV. 06/2015



SAFETY SUMMARY

GENERAL SAFETY NOTICES

The following general safety notices supplement the specific warnings and cautions appearing elsewhere in this manual. They are recommended precautions that must be understood and applied during operation and maintenance of the equipment covered herein. The general safety notices are presented in the following three sections labeled: First Aid, Operating Precautions and Maintenance Precautions. A listing of the specific warnings and cautions appearing elsewhere in the manual follows the general safety notices.

FIRST AID

An injury, no matter how slight, should never go unattended. Always obtain first aid or medical attention immediately.

OPERATING PRECAUTIONS

Always wear safety glasses.

Keep hands, clothing and tools clear of the evaporator and condenser fans.

No work should be performed on the unit until all circuit breakers and start-stop switches are turned off, and power supply is disconnected.

Always work in pairs. Never work on the equipment alone.

In case of severe vibration or unusual noise, stop the unit and investigate.

MAINTENANCE PRECAUTIONS

Beware of unannounced starting of the evaporator and condenser fans. Do not open the condenser fan grille or evaporator access panels before turning power off, and disconnecting and securing the power plug.

Be sure power is turned off before working on motors, controllers, solenoid valves and electrical control switches. Tag circuit breaker and power supply to prevent accidental energizing of circuit.

Do not bypass any electrical safety devices, e.g. bridging an overload, or using any sort of jumper wires. Problems with the system should be diagnosed, and any necessary repairs performed, by qualified service personnel.

When performing any arc welding on the unit, disconnect all wire harness connectors from the modules in the control box. Do not remove wire harness from the modules unless you are grounded to the unit frame with a static-safe wrist strap.

In case of electrical fire, open circuit switch and extinguish with CO₂ (never use water).



SPECIFIC WARNING AND CAUTION STATEMENTS

The statements listed below are applicable to the refrigeration unit and appear elsewhere in this manual. These recommended precautions must be understood and applied during operation and maintenance of the equipment covered herein.

SPECIFIC WARNINGS AND CAUTIONS

 **WARNING**

Be sure to observe warnings listed in the safety summary in the front of this manual before performing maintenance on the hvac system.

 **WARNING**

Read the entire procedure before beginning work. Park the coach on a level surface, with parking brake applied. Turn main electrical disconnect switch to the off position.

 **WARNING**

Do Not Use A Nitrogen Cylinder Without A Pressure Regulator

 **WARNING**

Do Not Use Oxygen In Or Near A Refrigeration System As An Explosion May Occur.

 **WARNING**

The Filter-drier May Contain Liquid Refrigerant. Slowly Loosen The Flare Nuts To Avoid Refrigerant Contact With Exposed Skin Or Eyes.

 **WARNING**

Extreme Care Must Be Taken To Ensure That All The Refrigerant Has Been Removed From The Compressor Crankcase Or The Resultant Pressure Will Forcibly Discharge Compressor Oil.

 **WARNING**

Be careful of remaining hot coolant in the hoses when disassembling.



CAUTION

Do not under any circumstances attempt to service the microprocessor. Should a problem develop with the microprocessor, replace it.



CAUTION

To prevent trapping liquid refrigerant in the manifold gauge set be sure set is brought to suction pressure before disconnecting.



CAUTION

Use care when checking/manipulating wires/plugs attached to the Logic Board. Damage to the board or wiring harness can occur.



TABLE OF CONTENTS

DESCRIPTION 1-1

1.1 INTRODUCTION 1-1

1.2 GENERAL DESCRIPTION 1-1

 1.2.1 Air Conditioning Unit Assembly 1-1

 1.2.2 Condensing System 1-1

 1.2.3 Evaporator System 1-4

 1.2.4 Compressor Assembly 1-5

 1.2.5 Fresh Air Connection 1-5

 1.2.6 System Operating Controls And Components 1-5

1.3 RELAY BOARD (12-00371-01) 1-8

1.4 LOGIC BOARD 1-9

1.5 CONTROL PANEL (Driver Controller) 1-9

1.6 CONTROL PANEL (Full Function Controller) 1-10

1.7 REFRIGERATION SYSTEM COMPONENT SPECIFICATIONS 1-10

1.8 ELECTRICAL SPECIFICATIONS CONDENSER MOTORS 1-11

1.9 ELECTRICAL SPECIFICATIONS - SENSORS AND TRANSDUCERS 1-11

1.10 ELECTRICAL SPECIFICATIONS -EVAPORATOR MOTORS 1-11

1.11 SAFETY DEVICES 1-11

1.12 AIR CONDITIONING REFRIGERATION CYCLE 1-13

1.13 HEATING CYCLE 1-13

OPERATION 2-1

2.1 STARTING, STOPPING AND OPERATING INSTRUCTIONS 2-1

 2.1.1 Power to Logic Board 2-1

 2.1.2 Starting 2-1

 2.1.3 Self-Test and Diagnostics (Check for Errors and/or Alarms) 2-2

 2.1.4 Stopping 2-2

2.2 PRE-TRIP INSPECTION 2-2

2.3 MODES OF OPERATION 2-2

 2.3.1 Temperature Control 2-3

 2.3.2 Cooling 2-3

 2.3.3 Heating 2-3

 2.3.4 Boost Pump (Optional) 2-4

 2.3.5 Vent Mode 2-4

 2.3.6 Compressor Unloader Control 2-4

 2.3.7 Evaporator Fan Speed Selection 2-4

 2.3.8 Fan Motor Operation Sequence 2-4

 2.3.9 Condenser Fan Control 2-5

 2.3.10 Compressor Clutch Control 2-5

 2.3.11 Liquid Line Solenoid Control 2-6

 2.3.12 Alarm Description 2-6



- 2.3.13 Hour Meters 2-6
- 2.4 MICROPROCESSOR DIAGNOSTICS 2-6
 - 2.4.1 Control 2-6
 - 2.4.2 Diagnostic Mode 2-6
 - 2.4.3 System Parameters 2-6
 - 2.4.4 Test Mode 2-7
- TROUBLESHOOTING 3-1**
 - 3.1 SELF DIAGNOSTICS 3-1
 - 3.2 SYSTEM ALARMS 3-1
 - 3.2.1 Alarm Codes 3-1
 - 3.2.2 Activation 3-1
 - 3.2.3 Alarm Queue 3-1
 - 3.2.4 Alarm Clear 3-1
 - 3.3 TROUBLESHOOTING 3-2
 - 3.3.1 Troubleshooting CAN Communication 3-2
 - 3.3.2 CAN Communication Command List 3-2
 - 3.3.3 System Will Not Cool 3-5
 - 3.3.4 System Runs But Has Insufficient Cooling 3-5
 - 3.3.5 Abnormal Pressures 3-5
 - 3.3.6 Abnormal Noise Or Vibrations 3-5
 - 3.3.7 Control System Malfunction 3-6
 - 3.3.8 No Evaporator Air Flow Or Restricted Air Flow 3-6
 - 3.3.9 Expansion Valve Malfunction 3-6
 - 3.3.10 Heating Malfunction 3-6
- SERVICE 4-1**
 - 4.1 MAINTENANCE SCHEDULE 4-1
 - 4.2 SUCTION AND DISCHARGE SERVICE VALVES 4-2
 - 4.3 MANIFOLD GAUGE SET 4-2
 - 4.3.1 Installing R-134a Manifold Gauge Set 4-2
 - 4.4 PUMPING THE SYSTEM DOWN OR REMOVING THE REFRIGERANT CHARGE 4-3
 - 4.4.1 System Pump Down For Low Side Repair 4-3
 - 4.4.2 Refrigerant Removal From An Inoperative Compressor. 4-4
 - 4.4.3 Pump Down An Operable Compressor For Repair 4-4
 - 4.4.4. Removing Entire System Charge 4-5
 - 4.5 REFRIGERANT LEAK CHECK 4-5
 - 4.6 EVACUATION AND DEHYDRATION 4-5
 - 4.6.1 General 4-5
 - 4.6.2 Preparation 4-5
 - 4.6.3 Procedure for Evacuation and Dehydrating System (Triple Evacuation) 4-6
 - 4.6.4 Procedure for Evacuation and Dehydrating System (One Time Evacuation) 4-6
 - 4.7 ADDING REFRIGERANT TO SYSTEM 4-6
 - 4.7.1 Checking Refrigerant Charge 4-6
 - 4.7.2 Adding Full Charge 4-6



4.7.3 Adding Partial Charge 4-7

4.8 CHECKING FOR NONCONDENSIBLES 4-7

4.9 CHECKING AND REPLACING HIGH OR LOW PRESSURE SWITCH 4-7

4.10 FILTER-DRIER 4-8

 4.10.1 To Check Filter-Drier 4-8

 4.10.2 To Replace Filter-Drier 4-8

4.11 SERVICING THE LIQUID LINE SOLENOID VALVE 4-8

 4.11.1 Coil Replacement 4-9

 4.11.2 Internal Part Replacement 4-9

 4.11.3. Replace Entire Valve 4-9

4.12 THERMOSTATIC EXPANSION VALVE 4-9

 4.12.1 Valve Replacement 4-10

 4.12.2 Superheat Measurement 4-10

4.13 REPLACING RETURN AIR FILTERS 4-11

4.14 COMPRESSOR MAINTENANCE 4-11

 4.14.1 Shaft Seal Reservoir 4-11

 4.14.2 Removing the Compressor 4-11

 4.14.3 Transferring Compressor Clutch 4-12

 4.14.4 Compressor Oil Level 4-13

 4.14.5 Checking Unloader Operation 4-14

4.15 TEMPERATURE SENSOR CHECKOUT 4-14

4.16 PRESSURE TRANSDUCER CHECKOUT 4-15

4.17 REPLACING SENSORS AND TRANSDUCERS 4-15

4.18 REMOVING THE CONDENSER FAN MOTOR (2 FAN APPLICATIONS) 4-16

4.19 REMOVING THE CONDENSER FAN MOTOR (3 FAN APPLICATIONS) 4-17

4.20 SERVICING THE EVAPORATOR FAN BLOWER MOTOR ASSEMBLY 4-17

 4.20.1 Removing and Disassembling 4-17

 4.20.2 Routine Examination and Cleaning 4-17

 4.20.3 Brush Replacement 4-18

4.21 SERVICING THE REHEAT COOLANT VALVE 4-19

 4.21.1 Reheat Coolant Valve Malfunctions 4-19

 4.21.2 Replacing the Coil 4-19

 4.21.3 Replacing the Internal Valve Parts 4-20

 4.21.4 Replacing the Valve Assembly 4-20

4.22 LOGIC BOARD REPLACEMENT 4-21

ELECTRICAL 5-1

5-1 INTRODUCTION 5-1



LIST OF TABLES

Table 1-1. Model Number Chart	1-3
Table 1-2. Additional Support Manuals	1-3
Table 2-1. Controller Test List	2-7
Table 2-2. Parameter Codes	2-8
Table 3-1 Error Codes	3-1
Table 3-2 Alarm Codes	3-3
Table 3-3. General System Troubleshooting Procedures	3-5
Table 4-1. Temperature Sensor Resistance	4-15
Table 4-2. Pressure Transducer Voltage	4-16
Table 4-3. Logic Board Configuration	4-20
Table 4-4. R-134a Temperature - Pressure Chart	4-21

LIST OF ILLUSTRATIONS

Figure 1-1. A/C Component Identification	1-1
Figure 1-2. Unit Assembly - Back View	1-4
Figure 1-3. Unit Assembly - Inside View (Typical)	1-5
Permanent Magnet-Typical	1-7
Brushless-Typical	1-7
Wound Field-Typical	1-7
Figure 1-4. Control Panels (Typical)	1-7
Figure 1-5 Relay Board (12-00371-01)	1-8
Figure 1-6 Logic Board	1-9
Figure 1-7. Micromate Control Panel (Driver Controller)	1-9
Figure 1-8. Micromate Control Panel (Full Function Controller)	1-10
Figure 1-9. Refrigerant Flow Diagram	1-13
Figure 2-1 Capacity Control Diagram	2-3
Figure 4-1.Suction or Discharge Service Valve	4-2
Figure 4-2. Manifold Gauge Set (R-134a)	4-2
Figure 4-3. Low Side Pump Down Connections	4-3
Figure 4-4. Compressor Service Connections	4-4
Figure 4-5. System Charge Removal Connections	4-5
Figure 4-6. Checking High Pressure Switch	4-7
Figure 4-7. Filter-Drier Removal	4-8
Figure 4-8. Liquid Line Solenoid Valve	4-9
Figure 4-9. Thermostatic Expansion Valve	4-10
Figure 4-10. Thermostatic Expansion Valve Bulb and Thermocouple	4-10
Figure 4-11. Compressors	4-12
Figure 4-12. Removing Bypass Piston Plug	4-12



LIST OF ILLUSTRATIONS (Continued)

Figure 4-13. Compressor Clutch 4-12

Figure 4-14 Transducer Terminal Location 4-15

Figure 4-15. Condenser Fan Motor Removal 4-16

Figure 4-16. Evaporator Fan Blower Removal 4-17

Figure 4-17. Reheat Coolant Valve Assembly 4-18

Figure 5-1. Wiring Schematic - Legend - 68RM35-610 (All) 5-2

Figure 5-2. Wiring Schematic - Control Circuit - 68RM35-610- 1 thru 9 5-3

Figure 5-3. Wiring Schematic - Power Circuit - 68RM35-610-3, -4, -5 5-4

Figure 5-4. Wiring Schematic - Power Circuit - 68RM35-610-1, -2 5-5

Figure 5-5. Wiring Schematic - Power Circuit - 68RM35-610, 6, -7, -8, -9 5-6

Figure 5-6. Wiring Schematic - Control Circuit - 68RM35-610-10 5-7

Figure 5-7. Wiring Schematic - Power Circuit - 68RM35-610-10 5-8

Figure 5-8. Wiring Schematic - Legend - Y13-R3501-00 & -02 5-9

Figure 5-9. Wiring Schematic - Control Circuit - Y13-R3501-00 & -02 5-10

Figure 5-10. Wiring Schematic - Power Circuit - Y13-R3501-00 & -02 5-11

Figure 5-11. Wiring Schematic - Legend - Y13-R3501-01 5-12

Figure 5-12. Wiring Schematic - Control Circuit - Y13-R3501-01 5-13

Figure 5-13. Wiring Schematic - Power Circuit - Y13-R3501-01 5-14

SECTION 1

DESCRIPTION

1.1 INTRODUCTION

This manual contains Operating Instructions, Service Instructions and Electrical Data for Mobile Climate Control Model 68RM35 and Y13-R3501 Air Conditioning and Heating equipment listed in Table 1-1.

Model 68RM35 and Y13-R3501 systems (see Figure 1-1) consists of a one piece air conditioning unit assembly, containing the condenser & evaporator, and engine compartment mounted compressor. To complete the system, the air conditioning and heating equipment interfaces with electrical cabling, refrigerant piping, engine coolant piping (for heating), duct work and other components furnished by the bus manufacturer.

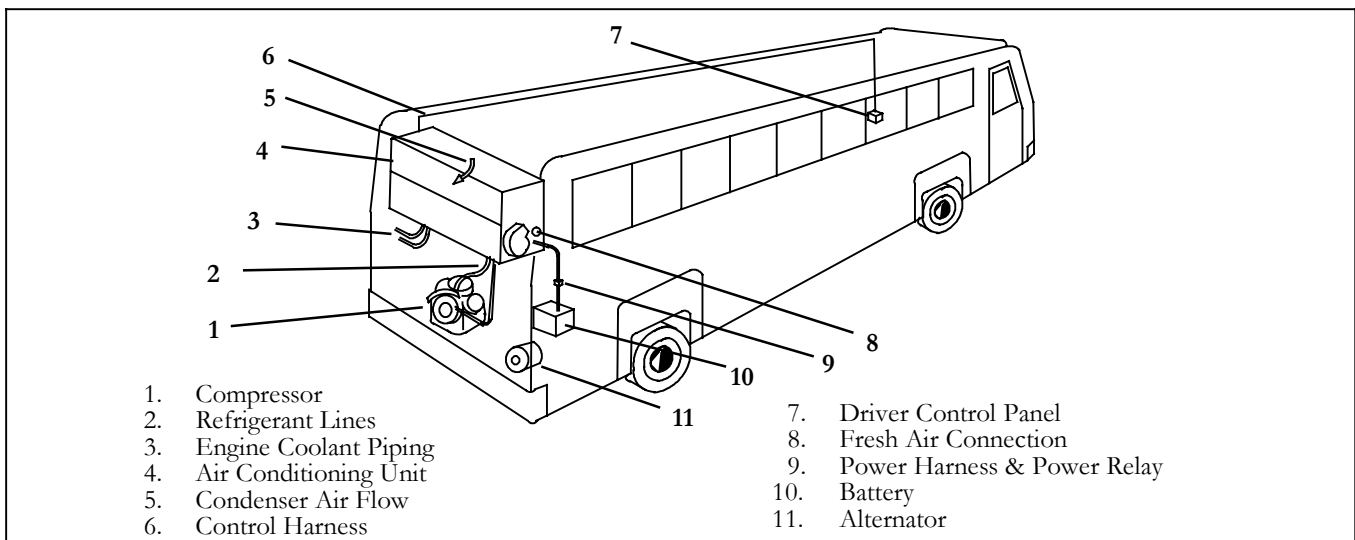

Figure 1-1. A/C Component Identification

1.2 GENERAL DESCRIPTION

1.2.1 Air Conditioning Unit Assembly

Operation of the units is controlled automatically by a microprocessor based Micromax Controller which maintains the vehicle's interior temperature at the desired set point.

The unit assembly (see Figure 1-2 and Figure 1-3) includes the condensing system equipment, evaporator system equipment, Micromax controller, and a fresh air connection. Components are accessible by opening the inside or outside covers. Descriptions of the systems are provided in the following sub paragraphs.

1.2.2 Condensing System

The condensing system includes the condenser coil, liquid-suction heat exchanger, fan and motor assemblies, filter-drier, receiver (with sight glasses and moisture indicator), liquid line solenoid valve,

discharge line check valve, discharge line connection, service valves, fusible plug and an ambient temperature sensor.

The discharge check valve is a spring loaded, normally closed valve that opens with the flow of refrigerant from the compressor. When the compressor clutch is disengaged, the discharge check valve will close, preventing the flow of high pressure liquid from the condenser back into the compressor.

The condenser coil provides heat transfer surface for condensing refrigerant gas at a high temperature and pressure into a liquid at high temperature and pressure. The condenser fans circulate ambient air across the outside of the condenser tubes at a temperature lower than refrigerant circulating inside the tubes, this results in condensation of the refrigerant into a liquid.

The receiver collects and stores liquid refrigerant. The receiver is fitted with upper liquid level sight glass to enable determination of refrigerant liquid



level and a lower moisture indicator to determine refrigerant moisture content. The receiver is also fitted with a fusible plug which protects the system from unsafe high pressure conditions. The liquid-suction heat exchanger further cools the liquid refrigerant to improve overall system efficiency. The filter-drier removes moisture and debris from the

liquid refrigerant before it enters the thermostatic expansion valve. The liquid line solenoid valve closes when the system is shut down to prevent flooding of coils with liquid refrigerant. The service valves enable isolation of the filter-drier for service. The ambient temperature sensor measures ambient temperature and sends an electrical signal to the controller.



Table 1-1. Model Number Chart

MODEL NUMBER	AUXILLARY EQUIPMENT CAPABILITY	CONTROL	CONDENSER MOTOR	EVAPORATOR MOTOR	FILTER
68RM35-610-1	NO	Reheat	Wound Field	Wound Field	Cleanable
68RM35-610-2	YES	Reheat	Wound Field	Wound Field	Cleanable
68RM35-610-3	NO	Reheat	Permanent Magnet w/ Resistor	Permanent Magnet	Cleanable
68RM35-610-4	YES	Reheat	Permanent Magnet w/ Resistor	Permanent Magnet	Cleanable
68RM35-610-5	NO	Reheat	Permanent Magnet w/ Resistor	Permanent Magnet	Cleanable
68RM35-610-6	YES	Reheat	Brushless	Brushless	Cleanable
68RM35-610-7	NO	Reheat	Brushless	Brushless	Cleanable
68RM35-610-8	NO	Reheat	Brushless	Brushless	Cleanable
68RM35-610-9	YES	Reheat	Brushless	Brushless	Cleanable
68RM35-610-10	NO	Reheat	Brushless	Brushless	Cleanable
Y13-R3501-00	YES	Reheat	Brushless	Brushless	Cleanable
Y13-R3501-01	YES	Reheat	Brushless	Brushless	Permatron
Y13-R3501-02	YES	Reheat	Brushless	Brushless	Cleanable

Table 1-2. Additional Support Manuals

MANUAL/FORM NUMBER	EQUIPMENT COVERED	TYPE OF MANUAL
T-356PL	68RM35-610 & Y13-R3501 Units	Service Parts List
T-333	ESS Cooling System	Operation and Service With Service Parts List

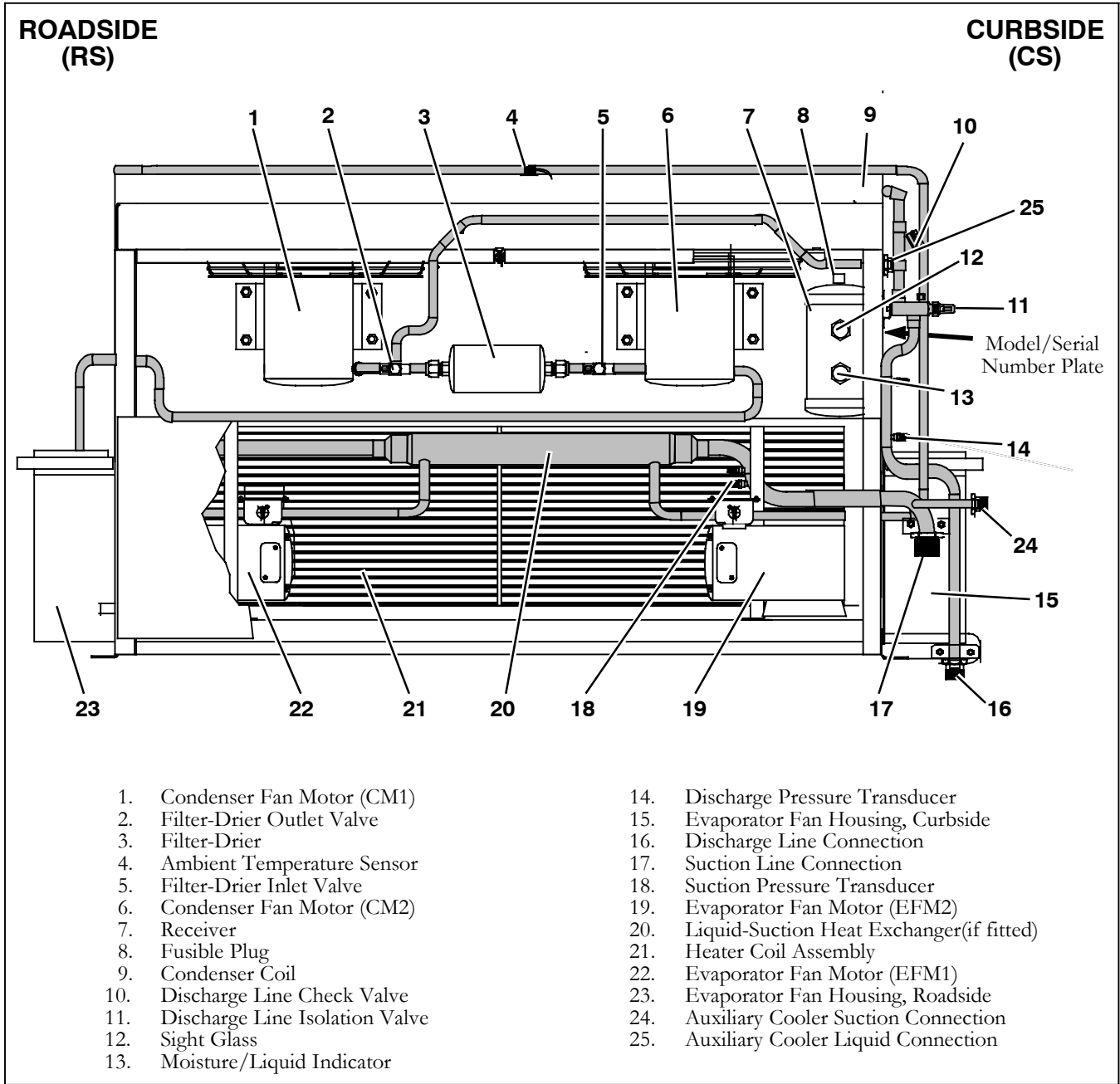

Figure 1-2. Unit Assembly - Back View (68RM35-610 Units)

1.2.3 Evaporator System

The evaporator system includes the evaporator coil, fan and motor assemblies, liquid-suction heat exchanger (if so equipped), heater coil assembly, a thermostatic expansion valve, and condensate drain connections.

The thermostatic expansion valve meters the flow of refrigerant entering the evaporator coil. The evaporator coil provides heat transfer surface for

transferring heat from air circulating over the outside the coil to refrigerant circulating inside the tubes; thus providing cooling. The liquid-suction heat exchanger absorbs heat from the liquid refrigerant further heating the suction gas, decreasing the possibility of liquid refrigerant from returning to the compressor. The heating coils provide heat transfer surface for transferring heat from engine coolant water circulating inside the tubes to air circulating over the outside surface of the tubes, thus providing

heating. The fans circulate the air over the coils. The air filters remove dirt particles from the air before it passes over the coils.

A heat valve controls the flow of engine coolant water to the heating coils upon receipt of a signal from the controller. The condensate drain connections provide a means for connecting tubing for disposing of condensate collected on the

evaporator coils during cooling operation.

1.2.4 Compressor Assembly

The compressor assembly includes the refrigerant compressor, clutch assembly, suction and discharge service valves, high pressure switch, low pressure switch, suction and discharge servicing (charging) ports and electric solenoid unloaders.

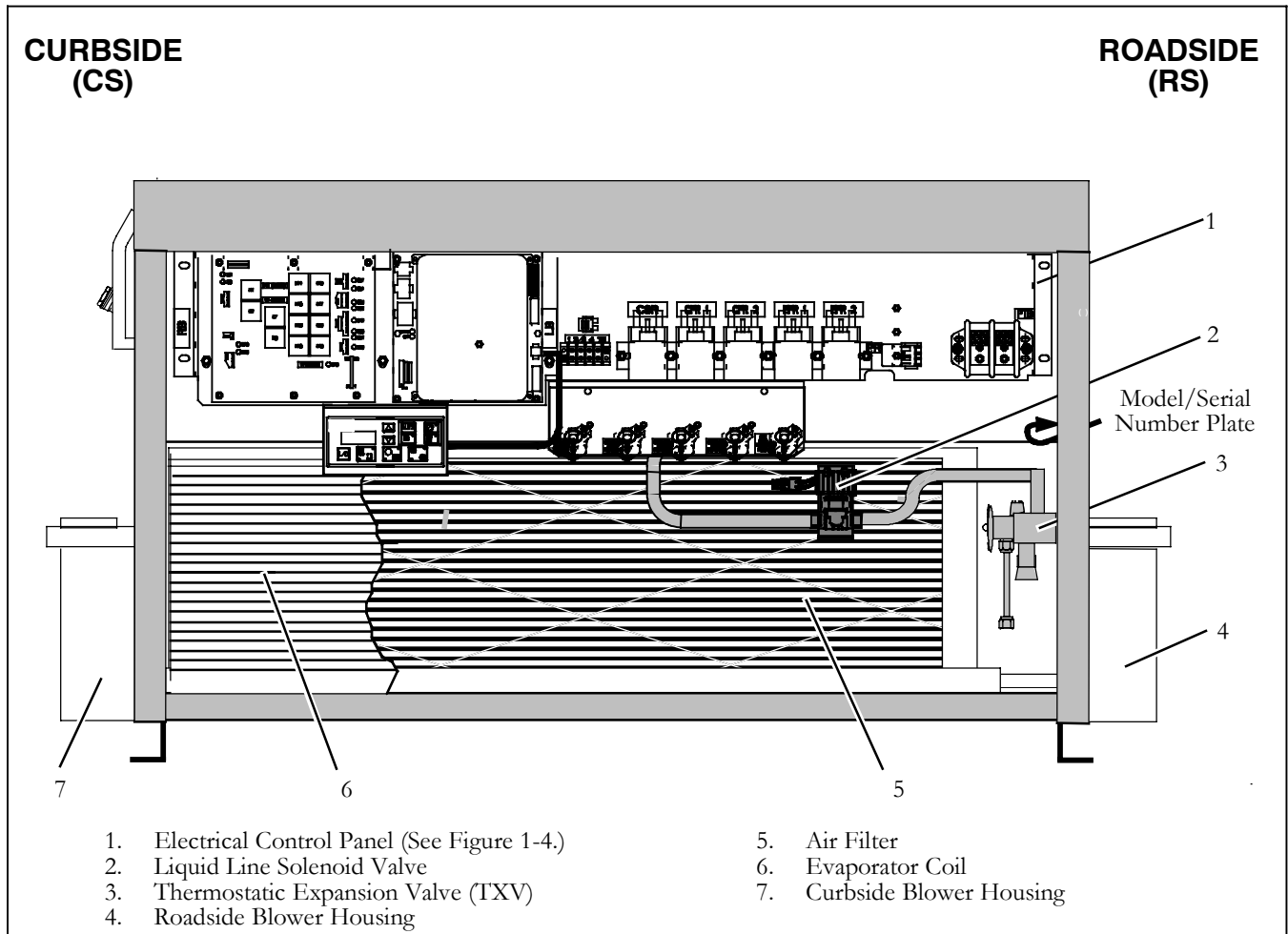

Figure 1-3. Unit Assembly - Inside View (Typical)

The compressor raises the pressure and temperature of the refrigerant and forces it into the condenser tubes. The clutch assembly provides a means of belt driving the compressor by the bus engine. The suction and discharge service valves enable servicing of the compressor. Suction and discharge servicing (charging) ports mounted on the service valves enable connection of charging hoses for servicing of the compressor, as well as other parts of the refrigerant circuit. The high pressure switch contacts open on a pressure rise to shut down the system when abnormally high refrigerant pressures occur.

The electric unloaders provide a means of controlling compressor capacity, which enables control of temperature inside the bus.

1.2.5 Fresh Air Connection

A connection (see Figure 1-1) is provided on the unit curb side for connection of the OEM supplied fresh air ducting.

1.2.6 System Operating Controls And Components

The system is operated by a Mobile Climate Control Micromax microprocessor controller (Figure 1-4) which consists of a logic board, relay board, circuit



breakers, relays, and an OEM supplied driver control panel or a MCC Micromate control panel (Figure 1-8). The logic board regulates the operational cycles of the system by energizing or de-energizing relays in response to deviations in interior temperature or system pressures. Modes of operation include Cooling, Heat and Vent. With the Micromate set in the AUTO mode, the logic board will cycle the system between the operating modes as required to maintain desired set point temperature.

In the vent mode the evaporator fans are operated to circulate air in the bus interior.

In the heat mode the heat valve and the OEM supplied floor blower and/or boost pump are energized. The evaporator fans operate to circulate

air over the evaporator coil in the same manner as the vent mode.

In the cooling mode the compressor is energized while the evaporator and condenser fans are operated. The compressor is fitted with cylinder unloaders to match compressor capacity to the bus requirements. Once interior temperature reaches the desired set point, the system may operate in the clutch cycle or reheat mode. A controller programmed for clutch cycle will de-energize the compressor clutch and allow the system to operate in the vent mode until further cooling is required. A controller programmed for reheat will maintain compressor operation and open the heat valve to allow reheating of the return air. In the reheat mode interior temperature is maintained at the desired set point while additional dehumidification takes place.

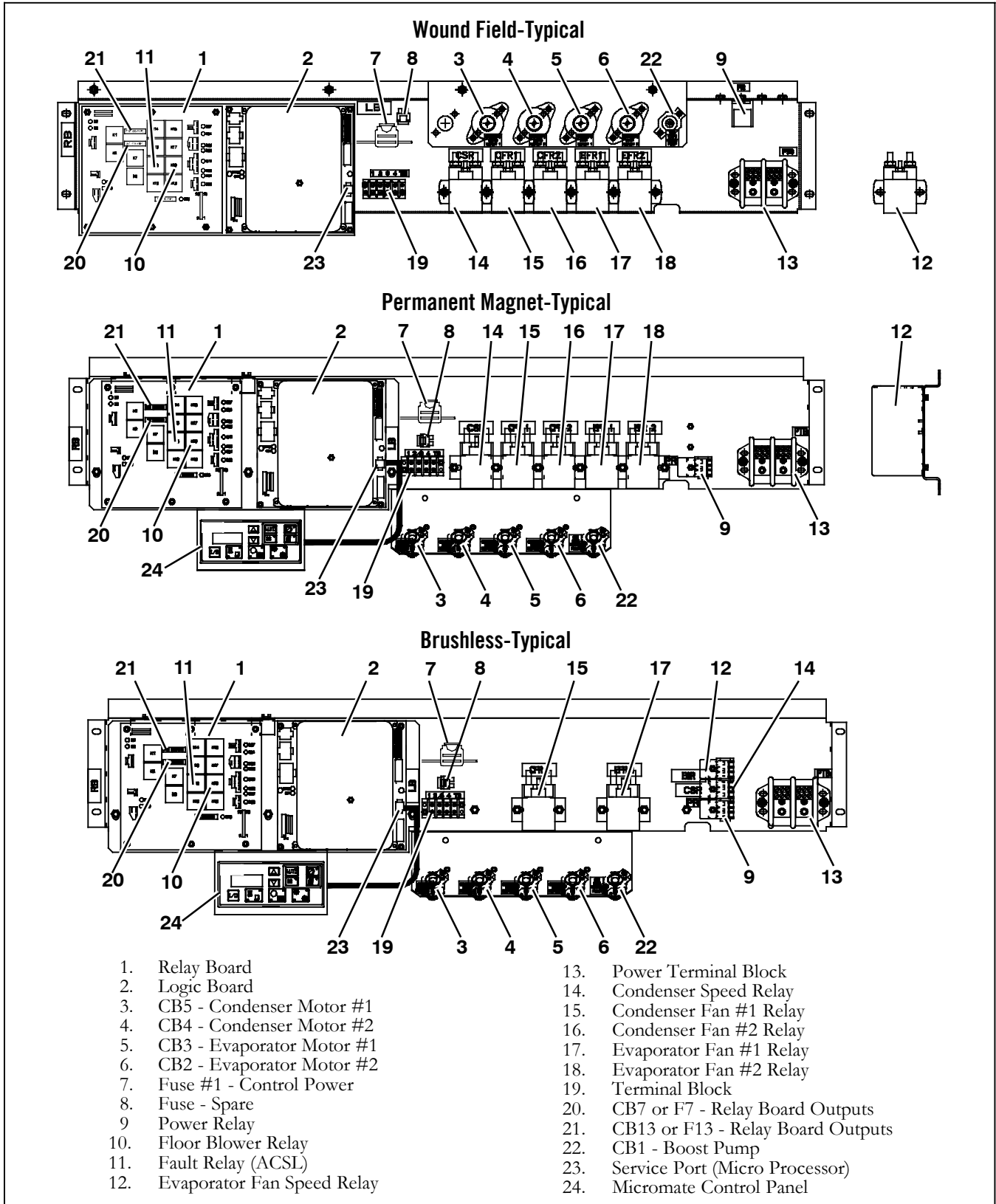
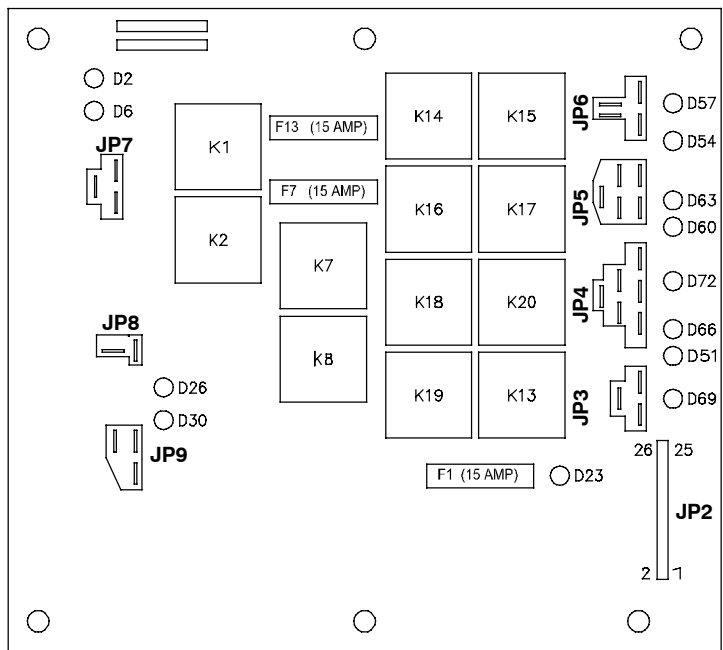

Figure 1-4. Control Panels (Typical)



1.3 RELAY BOARD (12-00371-01)



a. Relays

- K1 Energizes evaporator fans in low speed
- K2 Energizes evaporator fans in high speed (not energized in low speed).
- K 7 Energizes condenser fans in low speed
- K 8 Energizes condenser in high speed (not energized in low speed).
- K13 Energizes the A/C clutch and liquid line solenoid valve.
- K14 Energizes unloader 1.
- K15 Energizes unloader 2.
- K16 Spare.
- K17 Energizes reheat coolant valve
- K18 Energizes the fault light output.
- K19 Energizes the boost pump.
- K20 Spare.

b. Connectors

- JP1 Jumpers
- JP2 Logic board connector.
- JP3 Boost pump.
- JP4 A/C clutch, liquid line solenoid valve and fault output.
- JP5 Floor blower relay.
- JP6 Unloaders 1 & 2.
- JP7 Evaporator fan relays.
- JP8 24 Volt power input.
- JP9 Condenser fan relays.

c. LEDs

- D 2 Relay K2 output active (evaporator fan high speed relay energized)
- D 6 Relay K1 output active (evaporator fan relay energized)
- D26 Relay K7 output active (condenser fan relay energized)
- D30 Relay K8 output active (condenser fan high speed relay energized)
- D51 A/C clutch and liquid line solenoid valve output active.
- D54 Unloader 1 output active.
- D57 Unloader 2 output active.
- D63 Heat output active (RCV).
- D66 Fault output active.
- D69 Boost pump output active.
- D72 Floor blower output active.

d. Fuses

- F1 Logic board
- F7 Condenser motor contactors and speed relays.
- F13 All other control devices.

Figure 1-5 Relay Board (12-00371-01)



1.4 LOGIC BOARD

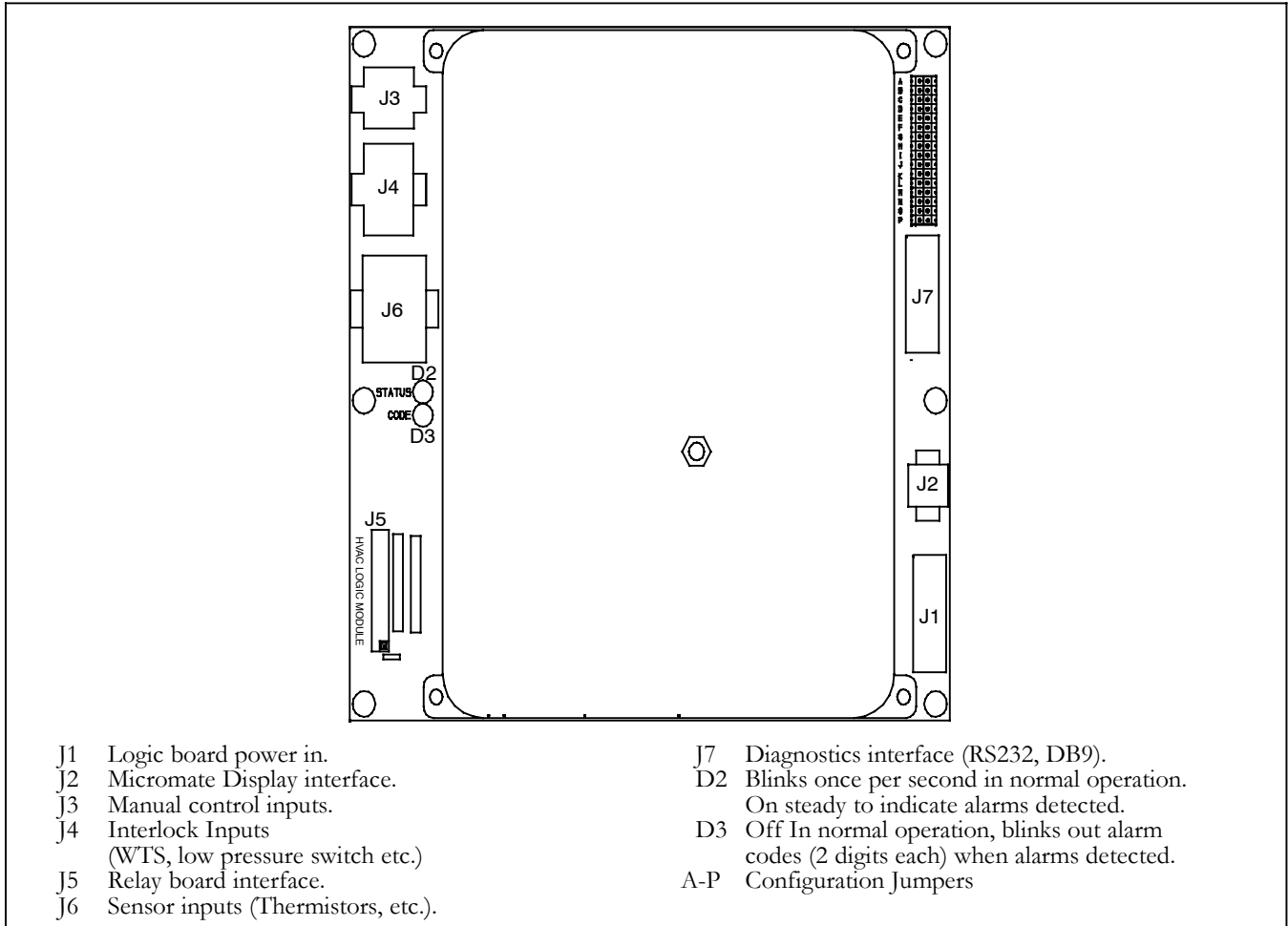

Figure 1-6 Logic Board

1.5 CONTROL PANEL (Driver Controller)

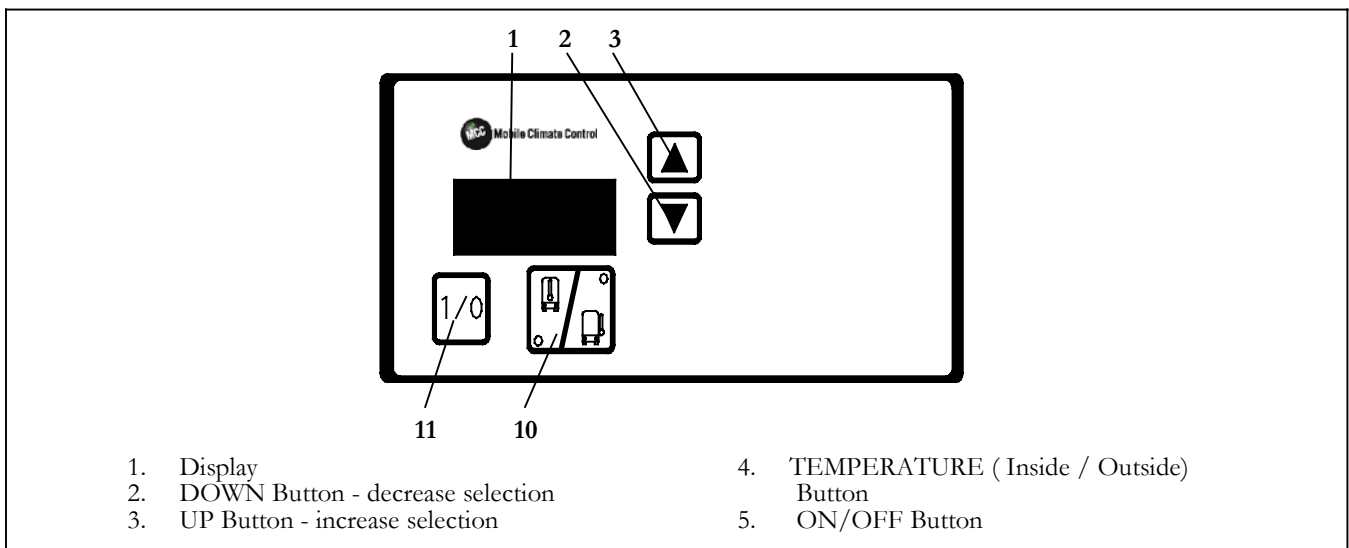

Figure 1-7. Micromate Control Panel (Driver Controller)



1.6 CONTROL PANEL (Full Function Controller)

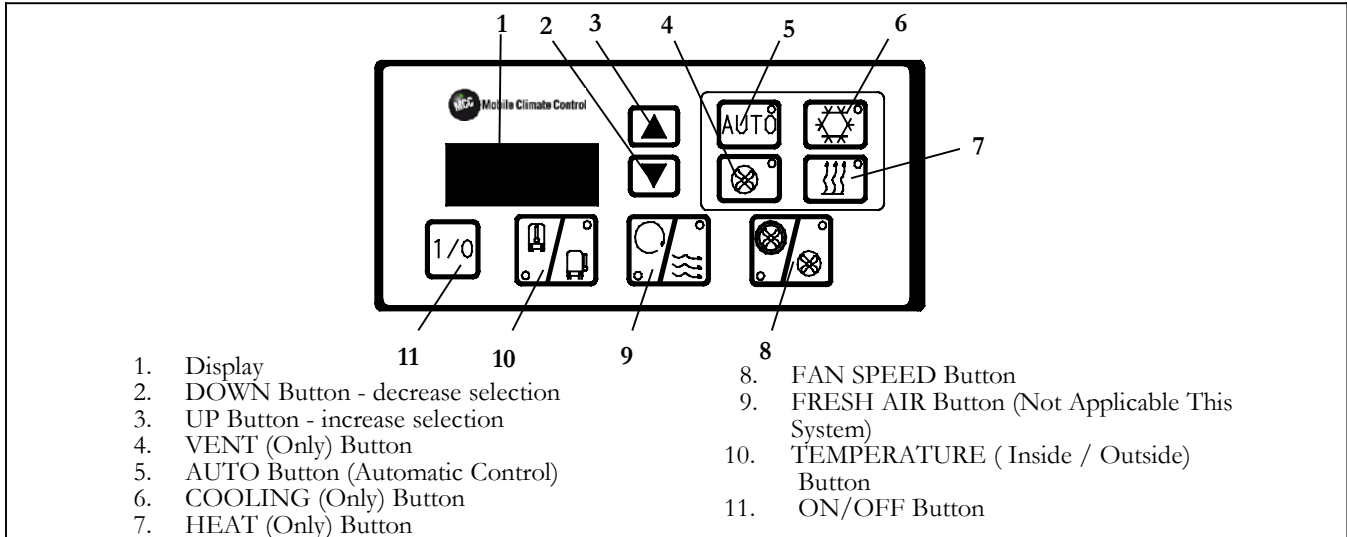

Figure 1-8. Micromate Control Panel (Full Function Controller)

1.7 REFRIGERATION SYSTEM COMPONENT SPECIFICATIONS

a. Refrigerant Charge

R-134a 17.0 lb (+ 0.50/-0.0 lb) (7.04 kg (+ 0.23/-0.0 kg))

With ESS unit added, an additional 2.0 lb (0.90 kg) required

b. Compressor

Compressor	05G
No of Cylinders	6
Weight - Dry, With Clutch	145 lbs (66 kg)
Oil Charge	5.5 pints (2.6 liters)

c. Compressor Oil

Oil Level:

Level in sight glass between Min.-Max marks on compressor crankcase

Approved Compressor Oils

Castrol: Icematic SW68C

Mobil: EAL Arctic 68

ICI: Emkarate RL68H

d. Thermostatic Expansion Valve:

Superheat Setting: 12 ± 3°F (5 to 8°C)

MOP Setting: 53.9 ± 4 psig (3.67 ± 0.27 bar)

e. High Pressure Switch (HPS):

Opens at: 300 ± 10 psig (20.41 ± 0.68bar)

Closes at: 200 ± 10 psig (13.61 ± 0.68bar)

f. Low Pressure Switch (LPS):

Opens at: 6 ± 3psig (0.41 ± 0.20 bar)

Closes at: 25 ± 3 psig (1.7 ± 0.20 bar)

g. Water Temperature Switch (WTS):

[Bus manufacturer supplied - suggested close on temperature rise at 105°F (41°C)]



1.8 ELECTRICAL SPECIFICATIONS CONDENSER MOTORS

MOTOR TYPE (refer to Table 1-1)	WOUND FIELD	PERMANENT MAGNET*	BRUSHLESS (2 Fan)	BRUSHLESS (3 Fan)
Voltage	27 VDC	27 VDC	24-28 VDC	24-28 VDC
Horsepower (kW)	0.8/0.5 (0.6/0.37)	0.75(0.56)	0.5(0.37)	0.5(0.37)
Full Load Amps	32/22	27	20	14.2
Operating Speed High/Low (RPM)	1800/1400	1800	1800	3930
Bearing Lubrication	Factory Lubricated (additional grease not required)	Factory Lubricated (additional grease not required)	Factory Lubricated (additional grease not required)	Factory Lubricated (additional grease not required)

*For permanent magnet with resistor applications, Resistor = 420 watts

1.9 ELECTRICAL SPECIFICATIONS - SENSORS AND TRANSDUCERS

a. Suction and Discharge Pressure Transducer

Supply Voltage: 4.5 to 5.5 vdc (5 vdc nominal)
Input Range: -6.7 to 450 psig (-0.46 to 30.62 bar)
Output Voltage: vdc = 0.0098 x psig + 0.4659
(See Table 4-2 for calculations.)

b. Temperature Sensors

Input Range: -52.6 to 158°F (-47 to 70°C)
Output: NTC 10K ohms at 77°F (25°C)
(See Table 4-1 for calculations.)

1.10 ELECTRICAL SPECIFICATIONS -EVAPORATOR MOTORS

MOTOR TYPE (refer to Table 1-1)	WOUND FIELD	PERMANENT MAGNET*	BRUSHLESS
Voltage	27 VDC	24-28 VDC	24-28 VDC
Horsepower (kW)	0.8/0.5 (0.6/0.37)	0.75(0.56)	0.75(0.56)
Full Load Amps	32/22	27	25
Full Load Amps	For Y13-R3501-01 ONLY		35/17
Operating Speed High/Low (RPM)	1800/1400	1800	1800
Bearing Lubrication	Factory Lubricated (additional grease not required)	Factory Lubricated (additional grease not required)	Factory Lubricated (additional grease not required)

*For permanent magnet with resistor applications, Resistor = 420 watts

1.11 SAFETY DEVICES

System components are protected from damage caused by unsafe operating conditions with safety devices. Mobile Climate Control supplied safety devices include a high pressure switch (HPS), low pressure switch (LPS), circuit breakers and fuses.

a. Pressure Switches

High Pressure Switch (HPS)

During the A/C mode, compressor operation will automatically stop if the HPS switch opens due to an

unsafe operating condition. Opening HPS de-energizes the compressor clutch shutting down the compressor. The high pressure switch is installed in the center head of the compressor.

Low Pressure Switch (LPS)

The low pressure switch is installed in the compressor and opens on a pressure drop to shut down the system when a low pressure condition occurs. In addition, if the control monitors a pressure less than 10 psig by the suction pressure



transducer mounted in the evaporator section, the system will be shut down for at least one minute.

b. Fuses and Circuit Breakers

The Unit is protected against high current by an OEM supplied 150 amp fuse or circuit breaker. The microprocessor is protected by a 10 amp fuse, while the relay board is protected with a 20 amp fuse. Independent 20, 40 or 60 amp circuit breakers protect each motor, depending on unit model. The output circuits are protected by additional 15 amp circuit breakers. During a high current condition, the breaker (or OEM fuse) may open. When power is removed from a device, a breaker alarm will be generated.

c. Ambient Lockout

The ambient temperature sensor located in the condenser section measures the condenser inlet air temperature. When the temperature is below the cut out set point the compressor is locked out until the temperature rises above the cut in setting. The set points will be programmed to cut out at 45°F (7.2°C) and cut in at 50°F (10°C). This setting protects the compressor from damage caused by operation at low temperatures.

d. Coil Freeze Protection (If Equipped)

The evaporator coil temperature sensor constantly monitors the coil temperature. If coil temperature reaches 32°F (0°C), an alarm will be generated, and the cooling circuit will shut down until the temperature rises above the cut in setting. Evaporator fans will continue to run to provide ventilation.



1.12 AIR CONDITIONING REFRIGERATION CYCLE

When air conditioning (cooling) is selected by the controller, the unit operates as a vapor compression system using R-134a as the refrigerant (see Figure 1-9).

The compressor raises the pressure and the temperature of the refrigerant and forces it thru the discharge lines into the condenser tubes. The condenser fan circulates surrounding air (which is at a temperature lower than the refrigerant) over the outside of the condenser tubes. Heat transfer is established from the refrigerant (inside the tubes) to the condenser air (flowing over the tubes). The condenser tubes have fins designed to improve the transfer of heat from the refrigerant gas to the air; this removal of heat causes the refrigerant to liquefy, thus liquid refrigerant leaves the condenser and flows to the receiver.

The receiver serves as a liquid refrigerant reservoir so that a constant supply of liquid is available to the evaporators as needed, and acts as a storage space when pumping down the system. The receiver is equipped with sight glasses to observe the refrigerant level and moisture content.

The refrigerant leaves the receiver and passes through the liquid/suction heat exchanger. The liquid/suction heat exchanger further cools the liquid by transferring heat to the suction gas. The liquid/suction heat exchanger improves efficiency by delivering the liquid to the expansion valve in a subcooled state. The refrigerant then flows to the filter drier which contains an absorbent that keeps the refrigerant clean and dry.

From the filter-drier, the liquid refrigerant then flows through the liquid line solenoid valve to the thermostatic expansion valve. The liquid line solenoid valve closes during shutdown to prevent refrigerant flow. The thermostatic expansion valve reduces pressure and temperature of the liquid and

measures the flow of liquid refrigerant to the evaporator to obtain maximum use of the evaporator heat transfer surface.

The low pressure, low temperature liquid that flows into the evaporator tubes is colder than the air that is circulated over the evaporator tubes by the evaporator fans. Heat transfer is established from the evaporator air (flowing over the tubes) to the refrigerant (flowing inside the tubes). The evaporator tubes have fins to increase heat transfer from the air to the refrigerant; therefore the cooler air is circulated to the interior of the bus.

The transfer of heat from the air to the low temperature liquid refrigerant in the evaporator causes the liquid to vaporize. This low temperature, low pressure vapor passes through the heat exchanger, where additional heat is transferred to ensure the refrigerant entering the compressor is in a vapor state. The refrigerant then continues through the suction line and returns to the compressor where the cycle repeats.

1.13 HEATING CYCLE

A heating coil is furnished in the unit assembly. Components furnished by the bus manufacturer may include a water temperature switch(WTS) and boost water pump. A solenoid operated reheat coolant valve may be supplied by the bus manufacturer or by Mobile Climate Control, depending on the application. The controller automatically controls the reheat coolant valve and boost pump during the heating and reheat modes to maintain required temperatures inside the bus. Engine coolant (glycol solution) is circulated through the heating circuit by the engine water pump. When the reheat coolant valve solenoid is energized, the valve will open to allow engine coolant to flow through the heater coil. The valve is normally closed so that if a failure occurs, the system will be able to cool.

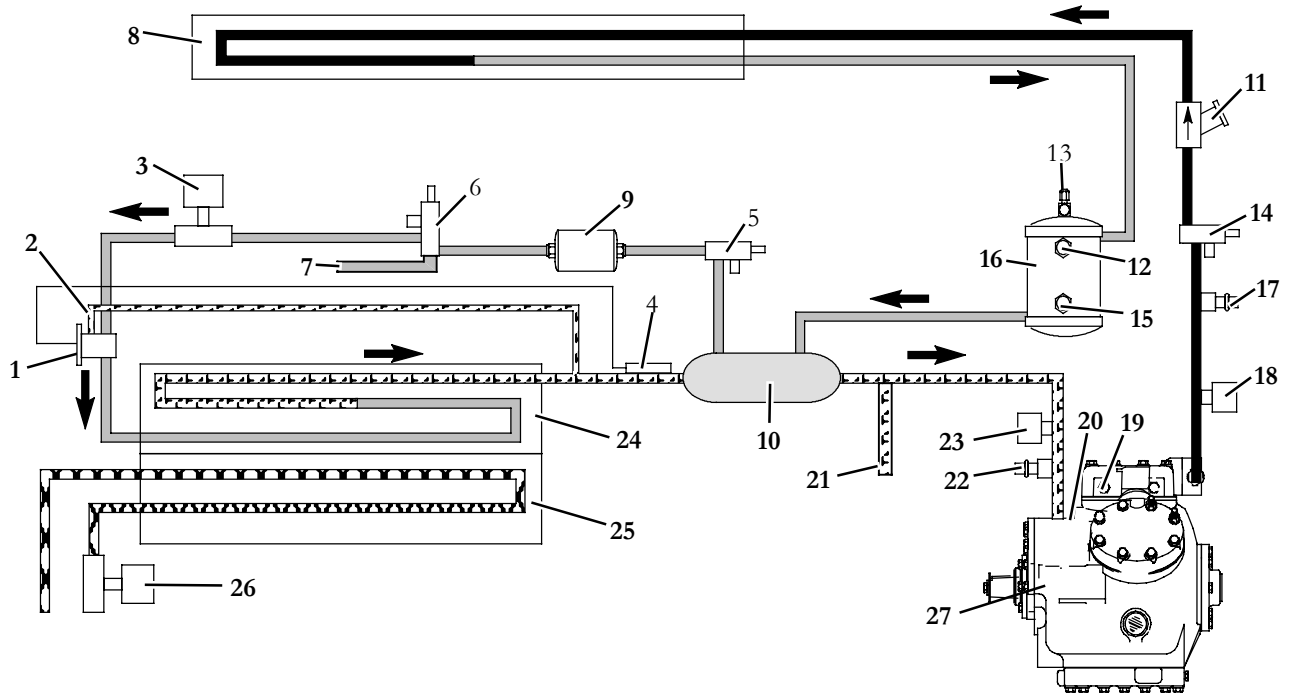

- | | |
|---------------------------------------|---|
| 1. Expansion Valve | 15. Moisture Indicator |
| 2. Expansion Valve Equalizer Line | 16. Receiver |
| 3. Liquid Line Solenoid Valve | 17. Service Port, High Side |
| 4. Expansion Valve Bulb | 18. Pressure Transducer, High Side |
| 5. Filter-Drier Inlet Service Valve | 19. High Pressure Switch |
| 6. Filter-Drier Outlet Service Valve | 20. Low Pressure Switch |
| 7. Auxiliary Cooler Liquid Connection | 21. Auxiliary Cooler Suction Connection |
| 8. Condenser Coil | 22. Service Port, Low Side |
| 9. Filter Drier | 23. Pressure Transducer, Low Side |
| 10. Liquid/Suction Heat Exchanger | 24. Evaporator Coil |
| 11. Discharge Check Valve | 25. Heater Coil |
| 12. Refrigerant Sight Glass | 26. Reheat Coolant Valve |
| 13. Fusible Plug | 27. Compressor |
| 14. Charge Isolation Valve | |

- LEGEND**
- DISCHARGE
 - LIQUID
 - SUCTION
 - COOLANT

Figure 1-9. Refrigerant Flow Diagram



SECTION 2 OPERATION

2.1 STARTING, STOPPING AND OPERATING INSTRUCTIONS

2.1.1 Power to Logic Board

Before starting, electrical power must be available from the bus power supply. The system components receive power from two sources:

- a. 24 vdc power for the microprocessor electronics is supplied through the bus interface.
- b. 24 vdc, 150 amp, fused power from the bus supplies power for the compressor clutch and unloader solenoids, evaporator and condenser assemblies; this power is controlled by the Logic Board.

2.1.2 Starting

- a. If the engine is not running, start the engine.

b. OEM SUPPLIED SWITCHES

Actual start sequence depends on the operating controls supplied. If only an ON/OFF switch is supplied, place the switch in the ON position to start the system in the automatic mode. If additional OEM switches are supplied, refer to the following Micromate control description for operating instructions.

c. MICROMATE CONTROL PANEL (Driver Controller)

The system will be started in the automatic mode.

1. The Micromate Control Panel (Figure 1-7) may be programmed to display the set point temperature or return air temperature. To determine which display temperature is programmed, press the TEMPERATURE button so that the OUTSIDE AIR indicator is illuminated. If the controller cycles back to the INSIDE AIR indicator, then the controller is programmed to display return air temperature. If the controller does not automatically cycle back to the return air indicator, then the controller is programmed to display set point temperature.
2. To start the system, press the I/O button to illuminate the indicator light and signal the Logic Board to perform start up. After the pre-trip inspection is completed, the switches may be set in accordance with the desired control modes.
3. To read interior or exterior temperature, press the TEMPERATURE button to illuminate the indicator light and bring the display to the desired

temperature reading. After a short delay, the display will return to the default set point or return air temperature reading.

4. Setpoint may be changed by pressing the UP or DOWN arrow button. The UP button will increase the setpoint temperature and the DOWN button will decrease the setpoint temperature.

d. MICROMATE CONTROL PANEL (Full Function Controller)

It is suggested the system be started in the automatic mode.

5. The Micromate Control Panel (see Figure 1-8) may be programmed to display the set point temperature or return air temperature. To determine which display temperature is programmed, press the TEMPERATURE button so that the OUTSIDE AIR indicator is illuminated. If the controller cycles back to the INSIDE AIR indicator, then the controller is programmed to display return air temperature. If the controller does not automatically cycle back to the return air indicator, then the controller is programmed to display set point temperature.
6. To start the system, press the I/O button to illuminate the indicator light and signal the Logic Board to perform start up. Ensure the AUTO button indicator is illuminated. If not, press the AUTO button to place the system in the automatic mode. After the pre-trip inspection is completed, the switches may be set in accordance with the desired control modes.
7. If cooling only, heating only or ventilation only is desired, press the corresponding button (refer to Figure 1-8) to illuminate the indicator light and place the system in that mode of operation.
8. If low or high speed evaporator fan speed is desired, press the FAN SPEED button to illuminate the indicator light and bring speed to the desired level.
9. To open or close the fresh air damper (if supplied), press the FRESH AIR button to illuminate the indicator light and bring the damper to the desired position.
10. To read interior or exterior temperature, press the TEMPERATURE button to illuminate the indicator light and bring the display to the desired temperature reading. After a short delay, the display will return to the default set point or return air temperature reading.



play will return to the default set point or return air temperature reading.

11. Setpoint may be changed by pressing the UP or DOWN arrow button. The UP button will increase the setpoint temperature and the DOWN button will decrease the setpoint temperature.
12. For additional Micromate operating data refer to paragraph 2.4.

2.1.3 Self-Test and Diagnostics (Check for Errors and/or Alarms)

Self-test of the main Logic Board electrical circuit is automatically initiated when the system is powered up. If there is an error in the circuit, an alarm will be indicated by flashing LED's on the Logic Board. If a Micromate is connected to the Logic Board, the error code can also be read on the display. If there are no errors in the circuit, system will operate normally and flash the status LED at a one second interval. During normal operation, the Logic Board monitors system operating parameters for out of tolerance conditions. If an out of tolerance condition occurs, *ALARM* will be indicated through the code LED or on the Micromate display. Refer to section 3 for definition of system errors and alarms and general troubleshooting procedures.

2.1.4 Stopping

Placing the ON/OFF switch in the OFF position or pressing the Micromate ON/OFF button will stop the system operation by removing power to the Logic Board. Note: If OEM switches at the dash are supplied, they will override control unless the J3 plug on the logic board is disconnected.

2.2 PRE-TRIP INSPECTION

After starting system, allow system to stabilize for ten to fifteen minutes and check for the following:

- a. Listen for abnormal noises in compressor or fan motors.
- b. Check compressor oil level. (Refer to section 4.14.4)
- c. Check refrigerant charge. (Refer to section 4.7.1)
- d. Ensure that self-test has been successfully performed and that there are no errors or alarms indicated. (Refer to section 2.1.3.)

2.3 MODES OF OPERATION

The system is operated by a Mobile Climate Control Micromax microprocessor controller which consists of a logic board (Figure 1-6), relay board (Figure 1-5), and manual operator switches. The logic board regulates operational cycles of the system by energizing or de-energizing Relay Board relays in response to deviations in interior temperature. Modes of operation include Cooling, Heat and Vent. Refer to Figure 2-1 and the following paragraphs for a description of each mode.

Figure 2-1 shows the Logic Board actions at various temperature deviations from setpoint. On rising temperature, changes occur when the temperature rises above Logic Board setpoints, On falling temperature, changes occur when temperatures falls below Logic Board set point. The system will operate in these modes unless pressures override the Logic Board settings.

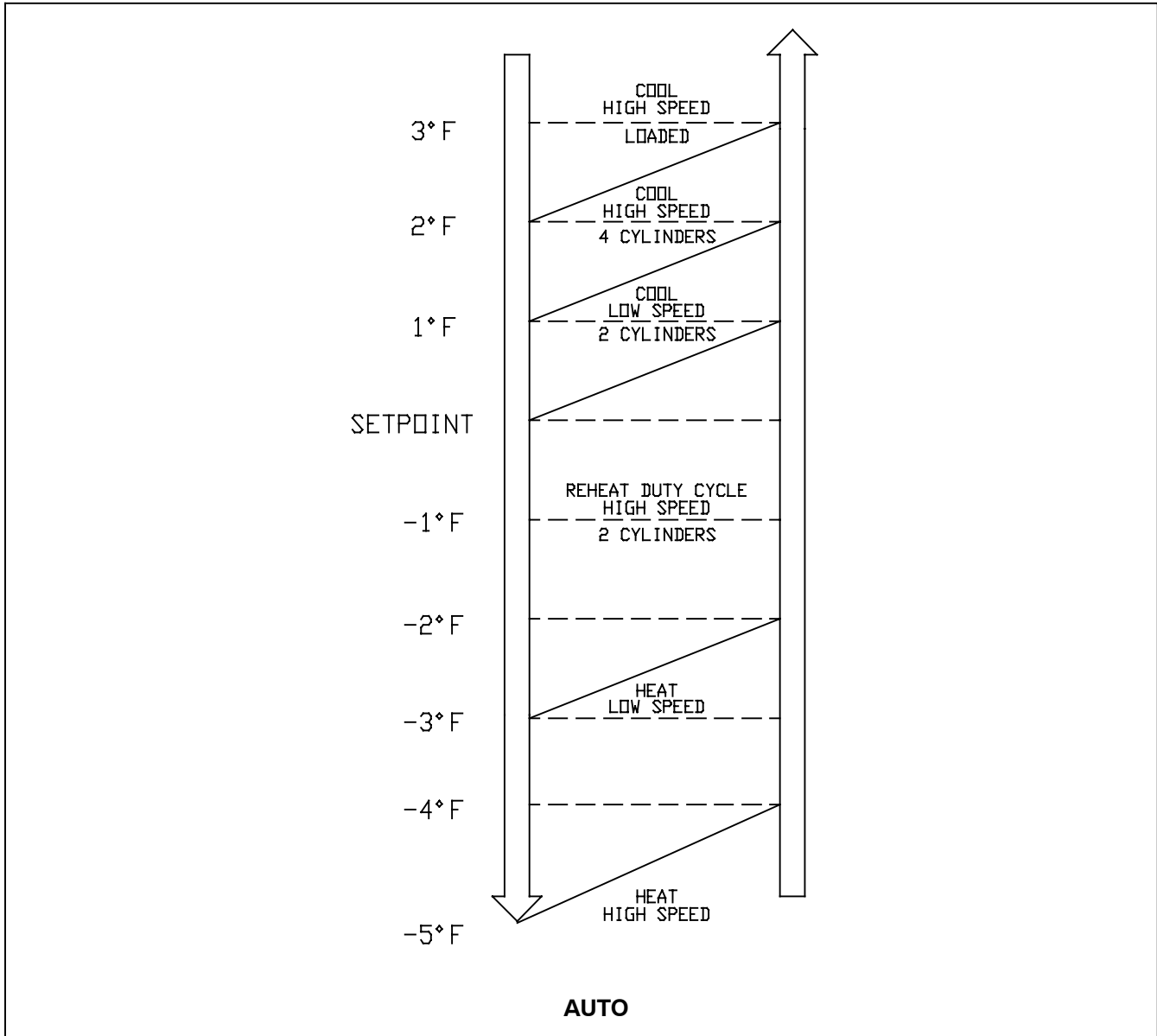

Figure 2-1 Capacity Control Diagram

2.3.1 Temperature Control

Temperature is controlled by maintaining the return air temperature measured at the return air grille.

2.3.2 Cooling

Cooling is accomplished by energizing the compressor and condenser fans, opening the liquid line solenoid valve and closing the heating valve. Once interior temperature reaches the desired set point, the system may operate in the clutch cycle or reheat mode. Selection of clutch cycle or reheat is factory programmed in accordance with the bus purchase specification.

A controller programmed for clutch cycle will de-energize the compressor clutch and allow the

system to operate in the vent mode until further cooling is required.

A controller programmed for reheat will maintain compressor operation and cycle the heat valve to allow reheating of the return air. In the reheat mode interior temperature is maintained at the desired set point while additional dehumidification takes place.

2.3.3 Heating

Heating is accomplished when the liquid line solenoid is closed and the compressor and condenser fans are shut down. The heat valve is opened to allow a flow of engine coolant through the heat section of the evaporator coil. The evaporator fans speed is varied as required to circulate air over



the evaporator coil based on the temperature difference from setpoint.

2.3.4 Boost Pump (Optional)

When the unit is in the heat mode, and if a boost pump is supplied by the coach manufacturer, the boost pump relay is energized, providing 24 VDC to activate the boost pump.

2.3.5 Vent Mode

In the vent mode the evaporator fans are operated to circulate air in the bus interior.

2.3.6 Compressor Unloader Control

When operating in cooling, the unloaders are used to reduce system capacity as return air temperature approaches set point. Operation of the unloaders balances system capacity with the load and thereby prevents overshoot from set point.

Relay Board mounted unloader outputs control the capacity of the compressor by energizing or de-energizing unloader solenoid valves. The model 05G compressor has three banks of two cylinders each. Energizing a valve de-activates a bank of cylinders. The outboard cylinder banks of the 05G are equipped with unloader valves (UV1 and UV2), each controlling two cylinders; this allows the 05G to be operated with two, four or six cylinders.

Whenever the compressor is started, the unloaders are energized for a preset delay time to reduce starting torque. After the delay, unloaders may be de-energized. Any subsequent changes between energizing and de-energizing the unloaders for temperature control is also staged for a preset delay time. Once an unloader is energized for pressure control, it remains energized for two minutes to prevent short cycling. Only one unloader may change state at a time when staging is required. Operating parameters for temperature control, suction pressure control and discharge pressure control are as follows.

a. Temperature Control

The unloaders are used to control system capacity by controlling compressor capacity.

1. Compressor Unloader UV1 Relay. When return air temperature falls to less than 2°F (1.1°C) above set point unloader UV1 is energized. If temperature rises to greater than 3°F (1.7°C) above set point, UV-1 will be de-energized to place the compressor at 100% capacity.
2. Compressor Unloader UV2 Relay. When return air temperature falls to less than 1°F (0.6°C)

above set point unloader UV2 is energized. If temperature rises to greater than 2°F (1.1°C) above set point, UV-2 will be de-energized to place the compressor at 66% capacity.

b. Suction Pressure

The unloaders are used to control suction pressure and thereby prevent coil frosting:

1. Compressor Unloader UV1 Relay. When the suction pressure decreases below 26 psig, unloader UV1 is energized unloading a cylinder bank (two cylinders); this output will remain energized until the pressure increases to above 34 psig.
2. Compressor Unloader UV2 Relay. When suction pressure decreases below 23 psig, unloader UV2 is energized unloading the second compressor cylinder bank; this output will remain energized until the pressure increases to above 31 psig.

c. Discharge Pressure

Discharge pressure is also controlled by the unloaders:

1. Compressor Unloader UV1 Relay. When the discharge pressure increases above 275 psig, unloader UV1 is energized; this unloader will remain energized until the pressure decreases below 220 psig.
2. Compressor Unloader UV2 Relay. When the discharge pressure increases above 285 psig, unloader UV2 is energized; this unloader will remain energized until the pressure decreases below 225 psig.

2.3.7 Evaporator Fan Speed Selection

Temperature control is the primary method of determining the fan speed selection. Section 2.3.8 describes relay operational status for the evaporator fans while Figure 2-1 provides Logic Board speed selections at various deviations from set point.

2.3.8 Fan Motor Operation Sequence

The evaporator and condenser fans are energized by relays on the relay board. Depending on relay board configuration the fan ON and fan HIGH SPEED relays may be energized directly by the microprocessor or energized by a set of interim relays.

On systems with relay board 12-00371-01 (see Figure 1-5) Power is available: from relay board terminal JP2-18 to the fan ON relays (K1 & K7) and fan HIGH SPEED relays (K2 & K8), and grounded thru terminals JP2-2, -3, -4, -5.



2.3.8.1 Fan Motor Operation Sequence, Permanent Magnet and Wound Field Motors

When condenser fan operation is required, the microprocessor energizes (grounds thru JP2-5) the condenser fan ON relay (K7). Relay K7 closes it's contacts to energize the condenser fan relays (CFR1 and CFR2). With the CFR relay contacts closed, power flows from CB4 & CB5, through the relay contacts to the condenser fan motors. The circuit continues through a resistor (R1), for permanent magnet motors, or through the motor low speed circuit (A2 to S2) for wound field motors.

When high speed condenser fan operation is required, the microprocessor energizes (grounds thru JP2-4) the HIGH SPEED relay K8. Relay K8 closes it's contacts to energize the condenser speed relay CSR. With the CSR relay contacts closed, power flows directly to ground from the permanent magnet motors, or through the motor High speed speed circuit (A2 to S3) for wound field motors.

When evaporator fan operation is required, the microprocessor energizes (grounds thru JP2-3) the relay K1. Relay K1 closes it's contacts to energize evaporator fan relays EFR1 & EFR2. With permanent magnet motors, a circuit is established from circuit breaker CB3 to the motors, in series, placing them in low speed. For wound field motors, the circuit is established through the motor low speed circuits (A2 to S2).

When high speed evaporator fan operation is required, the microprocessor energizes (grounds thru JP2-2) the evaporator fan HIGH SPEED relay K2. Relay K2 closes it's contacts to energize the evaporator speed relay ESR. With permanent magnet motors, the ESR contacts reverse allowing power from CB2 directly to EM2 and power from CB3 directly to EM1, placing them in high speed. For wound field motors, the circuit continues through the motor high speed circuit (A2 to S3).

2.3.8.2 Fan Motor Operation Sequence, Brushless Motors

When power is supplied to the logic board at J1-1, the CFR1 relay is also energized, supplying main power to condenser motors CM1 and CM2 through CB4 and CB5 (2 motor application) or condenser motors CM1, CM2 and CM3 through CB4, CB5 and CB6 (3 motor application). When condenser fan operation is required, the microprocessor energizes K7 relay coil by supplying a ground thru JP2-5. K7 relay contacts close, supplying control power thru the black/white (2 fan), or yellow (3 fan) motor control leads and thru the normally closed contacts of the condenser speed

relay (CSR) to the orange (2 fan), or blue (3 fan) motor control leads signaling low speed operation.

When high speed condenser fan operation is required, the microprocessor energizes the coil of the K8 relay by completing the ground thru JP2-4. The K8 relay energizes the condenser speed relay (CSR) coil which opens the contacts of the CSR, removing power from the orange (2 fan) or blue (3 fan) motor control leads signaling high speed operation.

When power is supplied to the logic board at J1-1, the EFR1 relay is also energized, supplying main power to evaporator motors EM1 and EM2 through CB2 and CB3. When evaporator fan operation is required, the microprocessor energizes K1 relay coil by supplying a ground thru JP2-3. K1 relay contacts close, supplying control power thru the white/black motor control leads and thru the normally closed contacts of the evaporator speed relay (ESR) to the orange motor control leads signaling low speed operation.

When high speed evaporator fan operation is required, the microprocessor energizes the coil of the K2 relay by completing the ground thru JP2-2. The K2 relay energizes the evaporator speed relay (ESR) coil which opens the contacts of the ESR, removing power to the orange motor control leads signaling high speed operation.

2.3.9 Condenser Fan Control

The condenser fans are energized when the compressor clutch output is energized. The fans are started in low speed and will remain in low speed until the discharge pressure increases to 190 psig. The fans will remain in high speed until discharge pressure decreases below 135 psig. The fans will also operate at high speed if a high pressure alarm has been activated and operation has not been locked out (refer to Table 3-2).

2.3.10 Compressor Clutch Control

A belt driven electric clutch is employed to transmit engine power to the air conditioning compressor. De-energizing the clutch electric coil disengages the clutch and removes power from the compressor. The clutch will be engaged when in cooling and disengaged when the system is off, in heating or during high and low pressure conditions.

The clutch coil will be de-energized if the discharge pressure rises to the cutout setting of the compressor mounted high pressure switch. An alarm will be triggered if this condition exists for more than a 0.5 second. The clutch coil will energize when the discharge pressure falls to the reset point of the high pressure switch.



The clutch coil will be de-energized whenever the suction pressure decreases below 10 psig. An alarm will be triggered if this condition exists for more than 10 seconds. The clutch coil will energize when the suction pressure rises to the reset point. If the alarm is triggered 3 times in a 30 minute time period the system will be locked out (See 3.2.1 Alarm Codes).

The clutch coil is prevented from engagement when the ambient temperature is below ambient lockout setpoint.

2.3.11 Liquid Line Solenoid Control

The liquid line solenoid is energized (open) when the compressor clutch is energized and de-energized (closed) when the clutch is not.

2.3.12 Alarm Description

Alarm descriptions and troubleshooting procedures are provided in section 3.

2.3.13 Hour Meters

Hour meter readings are available in the parameter code list of the Micromate. The hour meters record the compressor run time and the total time the evaporator fans are on. The maximum hours are 999,999. Refer to paragraph 2.4.2 for instructions on reading parameter codes.

2.4 MICROPROCESSOR DIAGNOSTICS

The Micromate allows the user to interface with the microprocessor based control. This allows system parameters, alarms and settings to be viewed and modified.

2.4.1 Control

NOTE

1. This procedure should be performed by an HVAC technician who has been trained on MCC Model RM system design. The control configuration is preset by the manufacturer and resetting of the parameters should not be required. It is recommended that MCC Service or Engineering is contacted before any control configuration is changed. MCC can not be responsible for failures or damage resulting from unauthorized changes.

2. If a replacement Logic Module is installed, it is necessary to match the configuration jumpers (refer to Figure 1-6) to the original board. Refer to paragraph 4.22.

- a. Turn the A/C main power switch (located in the driver's area) to OFF.
- b. Connect the Micromate to the logic board connector J2. (refer to Figure 1-6)
- c. Unplug the logic board connector J3. (refer to Figure 1-6)
- d. Turn the A/C main power switch back to the ON position.
- e. Activate the system by pressing the I/O key on the Micromate panel.

NOTE

Be sure to reconnect J3 when testing is completed or the system will fail to operate when the Micromate is disconnected.

NOTE

When modifying the setpoint temperature for diagnostic purposes, be sure to reset the setpoint when testing is complete.

2.4.2 Diagnostic Mode

The diagnostic mode can be entered by pressing the UP and DOWN arrow keys simultaneously for 3 seconds. The Micromate display screen will go blank for one second and then enter the alarm screen. The diagnostic mode allows alarms and system parameters to be viewed. If there are any alarms stored, the most recent alarm will be shown. To exit the diagnostic mode, press the ON/OFF key once, or do not touch any keys for 30 seconds. To view additional alarm information, refer to section 3.

2.4.3 System Parameters

To view system parameters, first enter the Diagnostic Mode. Refer to paragraph 2.4.2. The parameters are shown in Table 2-2. While in the diagnostic mode, press an UP or DOWN arrow key to switch the display to the Parameter Display. With the first Parameter displayed, press the DOWN arrow key to scroll through the list from the first to the last parameter or press the UP arrow to scroll from the last to the first parameter. When scrolling through the parameters, the current parameter will be displayed for two seconds. After two seconds, the



display will show the data for the current parameter. When the last parameter is reached, the list will wrap back to P1.

2.4.4 Test Mode

With the system in normal operation, the controller may be placed in the test mode, by doing the following:

- a. Enter the diagnostic mode by pressing the UP and DOWN arrow keys simultaneously for 3 seconds. The display should register “---”. Enter the test mode immediately by pressing the COOL button five times.
- b. In the test mode, the display will read “T##” where “##” indicated the test number that is currently running.
- c. The initial indication will be “T00”. This indicates the controller is in the test mode and all relays are de-energized. Press the DOWN arrow key to bring the Micromate to the next test screen and energize the corresponding component(s). Press the UP arrow key move backwards through the list. A listing of tests is provided in Table 2-1.

d. To terminate testing, press the I/O key.

Table 2-1. Controller Test List

TEST	OUTPUT	STATE
T00	All Relays	Off
T01	Evaporator Fans High	On
T02	Evaporator Fans Low	On
T03	Condenser Fans High	On
T04	Condenser Fans Low	On
T05	Compressor & Liquid Line Solenoid	On
T06	Unloader Valve 1	On
T07	Unloader Valve 2	On
T08	Not Applicable	On
T09	Reheat Coolant Valve	On
T10	Fault	On
T11	Boost	On
T12	Spare/Motor Input/	On
	Floor Blower	



Table 2-2. Parameter Codes

CODE	CODE NAME	DESCRIPTION
P1	Return Air Temperature	This value is the temperature measured by the return air sensor. If the sensor is shorted it will display <i>CL</i> . If it is open circuited it will display <i>OP</i> .
P2	Coil Temperature	This value is the temperature measured by the evaporator temperature sensor. If the sensor is shorted, it will display “CL”. If it is opened, it will display “OP”.
P3	Ambient Temperature	This value is the outside temperature measured by the ambient temperature sensor. If the sensor is shorted it will display <i>CL</i> . If it is open circuited it will display <i>OP</i> .
P4	Suction Line Temperature	Not used.
P5	Suction Pressure	This value is the suction pressure measured by the suction pressure transducer. If the sensor is shorted it will display <i>CL</i> If it is open circuited it will display <i>OP</i> .
P6	Discharge Pressure	This value is the discharge pressure measured by the discharge pressure transducer. If the sensor is shorted it will display <i>CL</i> and if it is open circuited it will display <i>OP</i> .
P7	Superheat	Not used.
P8	Analog Set Point Temperature	Not used.
P9	A/C Control Window #1	This is the number of degrees F above setpoint at which the unloaders will be both energized. This value can be modified between 0 and 10 degrees F. The default value is 1 degree F.
P10	A/C Control Window #2	This is the number of degrees F above AC control window one at which the first unloader will be energized. This value can be modified between 0 and 10 degrees F. The default value is 1 degree F.
P11	A/C Control Window #3	This is the number of degrees F above AC control window two at which the evaporator fan speed will be set to low. This value can be modified between 0 and 10 degrees F. The default value is 1 degree F.
P12	Heat Control Window	This is the number of degrees F below setpoint before the reheat coolant valve is energized. This value can be modified between 0 and 10 degrees F. The default value is 2 degree F for heat and 4 degrees F for reheat.
P13	Compressor Safety Off Delay	This number is the minimum time in minutes that the compressor must be off after a high or low pressure alarm before it can be restarted. This value can be modified between one and five minutes. The default value is 1.
P14	Fan Delay	This is the minimum time (in seconds) that the fans must run at a particular speed before changing to another speed. This value can be modified between one and 60 seconds. The default value is two seconds.
P15	Reheat Valve Delay	This is the minimum time (in seconds) that the reheat valve must be in a particular state (open /closed) before changing to another state. This value can be modified between 1 and 60 seconds. The default value is 2 seconds.
P16	Compressor High Pressure Switch	This is the current state of the compressor high pressure switch input. “CL” will be displayed if it is closed and “OP” will be displayed if it is open.
P17	Condenser Fan Speed Switch	Not used.
P18	Maximum Setpoint	This is the maximum value that the operator will be allowed to set the setpoint temperature. The value can be modified in degrees with the up and down keys to a value between 60°F and 80°F.
P19	Minimum Setpoint	This is the minimum value that the operator will be allowed to set the setpoint temperature. The value can be modified in degrees with the up and down keys to a value between 60°F and 80°F.



Table 2-2. Parameter Codes - Continued

Code	Code Name	Description
P20	Compressor Hours High	This is the number of hours of operation that the compressor has run with the clutch energized in thousands.
P21	Compressor Hours Low	This is the number of hours of operation that the compressor has run with the clutch energized in hundreds, tens and ones.
P22	Evaporator Hours High	This is the number (in thousands) of hours of operation with the evaporator fans energized.
P23	Evaporator Hours Low	This is the number (in hundreds, tens and ones) of hours of operation with the evaporator fans energized.
P24	Maintenance 1 Hour High	This is the value of compressor hours high (P20) at which maintenance alarm #1 will be activated. This value can be modified by the up and down arrow keys. If both high and low values are zero the alarm is disabled.
P25	Maintenance 1 Hour Low	This is the value of compressor hours low (P21) at which maintenance alarm #1 will be activated. This value can be modified by the up and down arrow keys. If both high and low values are zero the alarm is disabled.
P26	Maintenance 2 Hours High	This is the value of evaporator fan hours high (P22) at which maintenance alarm #2 will be activated. This value can be modified by the up and down arrow keys. If both high and low values are zero the alarm is disabled.
P27	Maintenance 2 Hours Low	This is the value of evaporator fan hours low (P23) at which maintenance alarm #2 will be activated. This value can be modified by the up and down arrow keys. If both high and low values are zero the alarm is disabled.
P28	Freeze Alarm Setting	This is the value at which the freeze alarm will be activated. The default value is 32°F. This value can be modified between 20°F and 40°F in one degree increments by using the arrow keys
P29	Relay Module Voltage	This is the voltage being supplied to the relay module.
P30	Main Board Software Version	This is the software version of the logic board.
P31	Display Software Version	This is the software version of the display module.
P32	Ki	Not used.
P33	Kp	Not used.
P34	Heat Set Point Offset	This value is the offset that can be used to change the points at which the unit switches between heat and vent in the heat mode. A positive value will raise the critical temperatures (winter use) and a negative value will decrease the critical temperatures (summer use).
P35	Default Display Temperature	This value determines what temperature value the driver's display will show as a default. When the value is OFF, set-point temperature is displayed. When the value is ON, return air temperature is displayed. This option is only available in logic module software revisions 1.9 and newer, and drivers display software revision 1.3 and newer. Otherwise P35 will not be active and set-point temperature will only be displayed as default.
P37	Seasonal Operation	This is a binary (ON or OFF) parameter for seasonal operation. When it is turn ON, the control will run automatic mode, and the Cool and Heat Mode input (J3-3 and J3-4) will determine the temperature set point. When Cool Mode input J3-3 is energized, there will be no offset for the set point. When Heat Mode input J3-4 is energized, the temperature set point will be offset by the value of P34.
P38	Evaporator Fan Operation in Heat Mode	This is a binary (ON or OFF) parameter. When set to the OFF position, the evaporator blowers will operate according to the values set for Auto Mode. When set to ON, the evaporator blowers will operate in low speed in Heat Mode.
P39	Compressor Minimum On time	When parameter is set to OFF, the minimum compressor on time will be 5 minutes. When set to ON, the minimum compressor on time will be 1 minute.



Table 2-2. Parameter Codes - Continued

Code	Code Name	Description
P40	Enable Hidden Alarm	This value determines if alarms A33 and A34 are displayed. When the value is OFF, alarms A33 and A34 will not be displayed. When the value is ON, alarms A33 and A34 will be displayed.
P41	Fresh Air Damper	Not used.
P42	Defrost Operation	This value determines if the defrost switch will override the Micromate controller. If the parameter is ON the defrost switch will initiate unit defrost whenever it senses a need for defrosting (the Micromate display will shut off in defrost). If the parameter is OFF the Micromate display will continue to operate and override the defrost switch.



SECTION 3 TROUBLESHOOTING



Do not under any circumstances attempt to service the microprocessor. Should a problem develop with the microprocessor, replace it.

3.1 SELF DIAGNOSTICS

A self test is performed by the Micromax Logic Board each time the board is powered up. Errors, if any, will be indicated and the unit will not be allowed to start. The error codes can be read by counting the

number of times that the Logic Board STATUS and CODE LED's (see Figure 1-6) flash simultaneously. The Micromate control panel display will indicate errors with the code ER-#, where "ER" is the error prefix and # is the error number.

Table 3-1 Error Codes

CODE	NAME	DESCRIPTION
ER 1	Data Memory	Logic board data memory failure.
ER 2	Program Memory	Logic board program memory failure.
ER 3	A/D	A/D and multiplexer failure.
ER 4	Communication Failure	Failure in communication between the logic board and MDST.
ER 5	Program Memory	Display program memory failure.

3.2 SYSTEM ALARMS

3.2.1 Alarm Codes

The Micromax Logic Board continuously monitors system parameters and will generate an ALARM if a parameter exceeds preset limits. Alarms are indicated and the controller will respond in accordance with the information provided in Table 3-2. The alarm codes can be read by counting the number of times that the Logic Board CODE LED (see Figure 1-6) flashes. Each alarm code is a two digit number, the first set of flashes is the first digit and (after a slight pause) the second set of flashes is the second digit.

The Micromate control panel display will indicate alarms with the code A-## or i-##, where "A" is an active alarm prefix, "i" is an inactive alarm prefix and ## is the alarm number. If no alarms are present, the display will show "---". To access the alarm codes, press the UP and DOWN arrow keys at the same time and hold for 3 seconds. If multiple alarms are present the user can scroll through each alarm by pressing the AUTO key. When the end of the alarm list is reached the display will show "---". Press VENT to scroll backward from the latest alarm to the earliest alarm in the queue. When using the

VENT key to scroll back, only the alarm code will be shown, the alarm time will not be shown. If the AUTO key is held down for five seconds while "---" is displayed all inactive alarms are cleared. A listing of alarm codes is provided in Table 3-2.

3.2.2 Activation

When alarms are detected, they are placed in an alarm queue in the order at which they initiated unless the alarm is already present. Each alarm recorded will also capture an evaporator hour meter reading corresponding to the activation time. If the AUTO key is pressed while an alarm is displayed, the activation time capture will be shown.

3.2.3 Alarm Queue

The alarm queue consist of 10 alarm locations. When the alarm queue is full the Logic Board will take the required action but the alarm will not be recorded. When this situation occurs, an "Alarm Queue Full" alarm will be generated. When the alarms are viewed this will be the first alarm to be shown.

3.2.4 Alarm Clear

The user may clear inactive alarms using the Micromate control panel keypad. Refer to paragraph 3.2.1.



3.3 TROUBLESHOOTING

General procedures for system troubleshooting are provided in Table 3-3

3.3.1 Troubleshooting CAN Communication

NOTE

On the 12-00693-00 board the CAN communication line pins are on J4-PIN 14(CAN High, CAN_H) and J4-PIN 15 (CAN Low, CAN_L). The unit will continually broadcast messages.

Tools Required: RS232 adaptor, Voltmeter and CAN USB adaptor

Follow these steps:

1. Check CAN_H (J4-14) and CAN_L (J4-PIN15) is connected to the bus CAN High and Low lines.
2. Check Bus CAN line has a shunt 250Ohm resistor.
3. Disconnect J4 connector and connect the RS232 adapter.
4. Connect RS232 cable to CAN USB adaptor attached to a laptop.
5. Open HyperTerminal by following “start\All Programs\Accessories\Communications”.
6. Select 'disconnect' and set communication settings (Baud Rate 9600, Data Bits 8, Stop Bits 1, No Parity) by following 'File Properties'.
7. Select 'connect'.
8. Enable CAN communication by sending the following commands:
 - 8a. 'S5' then 'enter key'
 - 8b. 'O' then 'enter key'
9. **Check board is transmitting.** A continual stream of text like given below should display.

```
T18FFE1198F1FFFFFF4FFFF03FF
```

10.If there is no stream of text, **STOP**. The CAN chip is not functioning.

11.Check the Board receives and responds to commands by sending the following command to turn the AC OFF.

```
T18EF1921800FFFFFFFFFFFFFFF
```

Then 'enter key' and wait at least 1 minute for response.

12.If the AC does not shut down then go to step 14.

13.Send the following command to turn the AC ON.

```
T18EF1921840FFFFFFFFFFFFFFF
```

Then 'enter key' and wait at least 1 minute for response.

14. Send the following command to set Fan Speed to Low.

```
T18EF19218FDFFFFFFFFFFFFFFF
```

Then 'enter key' and wait at least 1 minute for response.

15.If there is no response, **STOP**. The CAN chip is not functioning.

3.3.2 CAN Communication Command List

1. HVAC Main Switch ON:

```
T18EF192187FFFFFFFFFFFFFFF
```

2. HVAC Main Switch OFF:

```
T18EF192183FFFFFFFFFFFFFFF
```

3. Low Fan Speed ON:

```
T18EF19218FDFFFFFFFFFFFFFFF
```

4. Low Fan Speed OFF:

```
T18EF19218FCFFFFFFFFFFFFFFF
```

5. Vent:

```
T18EF19218FF0FFFFFFFFFFFFFFF
```

6. Heat:

```
T18EF19218FF1FFFFFFFFFFFFFFF
```

7. Cool:

```
T18EF19218FF2FFFFFFFFFFFFFFF
```

8. Auto:

```
T18EF19218FF5FFFFFFFFFFFFFFF
```

9. Set Point (75 F):

```
T18EF19218FFFF40FFFFFFFFFFFFFFF
```

10. Boost Pump OFF:

```
T18EF19218F3FFFFFFFFFFFFFFF
```

11. Boost Pump ON:

```
T18EF19218F7FFFFFFFFFFFFFFF
```



Table 3-2 Alarm Codes

ALARM NO.	TITLE	CAUSE	REMEDY	CONTROLLER RESPONSE
A11	Coil Freeze	Coil temperature is less than 32°F and the compressor is operating.	Check causes of coil freezing. (Refer to section 3.3.8)	An alarm will be generated and the system will shut-down. The evaporator fans will remain running while the compressor is off.
A12	High Voltage	The battery voltage is greater than 32 volts.	Check, repair or replace alternator.	The system is shut down until the voltage returns to normal levels.
A13	Low Voltage	The battery voltage is less than 17 volts.	Check, repair or replace wiring or alternator.	The system is shut down until the voltage returns to normal levels.
A14	Return Air Probe Failure	Return air temperature sensor failure or wiring defective.	Ensure all connectors are plugged in. Check sensor resistance or wiring. Refer to paragraph 4.15. Replace sensor or repair wiring.	All outputs except the evaporator fans will be de-energized.
A15	Suction Pressure Transducer Failure	Suction pressure transducer failure or wiring defective.	Ensure all connectors are plugged in. Check sensor voltage or wiring. Replace sensor or repair wiring.	Both unloaders are energized.
A16	Discharge Pressure Transducer Failure	Discharge pressure transducer failure or wiring defective.	Ensure all connectors are plugged in. Check sensor voltage or wiring. Replace sensor or repair wiring.	One unloader is energized. Condenser fans will run on high speed.
A17	Low Pressure Shutdown	Low suction pressure switch open or wiring defective.	Check cause of low suction pressure. (Refer to section 3.3.5)	The clutch is de-energized for the minimum off time. The evaporator fans will remain running during this period. After the compressor cycles off three times in 30 minutes all outputs will be de-energized (except for the evaporator fans and heat) and the system is locked out until the power is cycled or the alarm is reset.
A21	High Discharge Pressure	High discharge pressure switch open or wiring defective.	Check discharge pressure transducer reading, wiring or cause of high discharge pressure. (Refer to section 3.3.5)	The clutch is de-energized for the minimum off time. The condenser and evaporator fans will remain running during this period. After the compressor cycles off three times in 30 minutes all outputs will be de-energized (except for the evaporator fans and heat) and the system is locked out until the power is cycled or the alarm is reset.



Table 3-2. Alarm Codes - Continued

ALARM NO	TITLE	CAUSE	REMEDY	CONTROLLER RESPONSE
A22	Breaker Trip Alarm	A breaker on the relay board has tripped or a fan relay has failed.	Check breakers for tripped device. Repair short and reset breaker.	Alarm will be generated.
A23	Evaporator Fan Overload	Evaporator fan overload jumper is open.	Ensure connector is plugged in or repair wiring.	Alarm will be generated.
A24	Condenser Fan Overload	Condenser fan overload jumper is open.	Ensure connector is plugged in or repair wiring.	Alarm will be generated.
A25	Not used			
A26	Not used			
A31	Maintenance Alarm 1	The compressor hour meter is greater than the value in Maintenance Hour Meter 1.	Reset the maintenance hour meter.	Alarm will be generated.
A32	Maintenance Alarm 2	The evaporator hour meter is greater than the value in Maintenance Hour Meter 2.	Reset the maintenance hour meter.	Alarm will be generated.
A33	Low Pressure Warning	Suction pressure low enough to energize UV2.	Check cause of low suction pressure. (Refer to section 3.3.5)	Alarm will be generated.
A34	High Pressure Warning	Discharge pressure high enough to energize UV2.	Check cause of high discharge pressure. (Refer to section 3.3.5)	Alarm will be generated.
A99	Alarm Queue Full	All locations of the alarm queue are currently full and no more alarms can be saved.	Record and clear alarm queue.	Alarm will be generated.



Table 3-3. General System Troubleshooting Procedures

INDICATION/ TROUBLE	POSSIBLE CAUSES	REFERENCE SECTION
3.3.3 System Will Not Cool		
Compressor will not run	Active system alarm V-Belt loose or defective Clutch coil defective Clutch malfunction Compressor malfunction	3.2 Check Check/Replace Check/Replace See Table 1-2
Electrical malfunction	Coach power source defective Circuit Breaker/safety device open	Check/Repair Check/Reset
3.3.4 System Runs But Has Insufficient Cooling		
Compressor	V-Belt loose or defective Compressor valves defective	Check See Table 1-2
Refrigeration system	Abnormal pressures No or restricted evaporator air flow Expansion valve malfunction Restricted refrigerant flow Low refrigerant charge Service valves partially closed Safety device open Liquid solenoid valve stuck closed	3.3.5 3.3.8 3.3.9 4.10 4.7 Open 1.11 Check
Restricted air flow	No evaporator air flow or restriction	3.3.8
Heating system	Reheat coolant valve stuck open	3.3.10
3.3.5 Abnormal Pressures		
High discharge pressure	Discharge transducer failure Refrigerant overcharge Noncondensable in system Condenser motor failure Condenser coil dirty	Replace 4.7.1 Check Check Clean
Low discharge pressure	Discharge transducer failure Compressor valve(s) worn or broken Low refrigerant charge	See Note. See Table 1-2 4.7
High suction pressure	Compressor valve(s) worn or broken	See Table 1-2
Low suction pressure	Suction service valve partially closed Filter-drier inlet valve partially closed Filter-drier partially plugged Low refrigerant charge Expansion valve malfunction Restricted air flow Suction transducer failure	Open Check/Open 4.10 4.7 3.3.9 3.3.8 Replace
Suction and discharge pressures tend to equalize when system is operating	Compressor valve defective	See Table 1-2
3.3.6 Abnormal Noise Or Vibrations		
Compressor	Loose mounting hardware Worn bearings Worn or broken valves Liquid slugging Insufficient oil Clutch loose, rubbing or is defective V-belt cracked, worn or loose Dirt or debris on fan blades	Check/Tighten See Table 1-2 See Table 1-2 3.3.9 4.14.4 Check Check/Adjust Clean



Table 3-3 General System Troubleshooting Procedures - Continued

INDICATION/ TROUBLE	POSSIBLE CAUSES	REFERENCE SECTION
3.3.6 Abnormal Noise Or Vibrations - Continued		
Condenser or evaporator fans	Loose mounting hardware Defective bearings Blade interference Blade missing or broken	Check/Tighten Replace Check Check/Replace
3.3.7 Control System Malfunction		
Will not control	Sensor or transducer defective Relay(s) defective Microprocessor controller malfunction Logic Board J3 connector unplugged	4.15 or 4.16 Replace Check Check
3.3.8 No Evaporator Air Flow Or Restricted Air Flow		
Air flow through coil blocked	Coil frosted over Dirty coil Dirty filter	Defrost coil Clean Clean/Replace
No or partial evaporator air flow	Motor(s) defective Motor brushes defective Evaporator fan loose or defective Fan damaged Return air filter dirty Icing of coil Fan relay(s) defective Safety device open Fan rotation incorrect	Repair/Replace Replace Repair/Replace Repair/Replace Clean/Replace Clean/Defrost Check/Replace 1.11 Check
3.3.9 Expansion Valve Malfunction		
Low suction pressure with high superheat	Low refrigerant charge Wax, oil or dirt plugging valve orifice Ice formation at valve seat Power assembly failure Loss of bulb charge Broken capillary tube	4.7 Check 4.6 Replace Replace 4.12
Low superheat and liquid slugging in the compressor	Bulb is loose or not installed. Superheat setting too low Ice or other foreign material holding valve open	Tighten/Install 4.12 4.12
Side to side temperature difference (Warm Coil)	Wax, oil or dirt plugging valve orifice Ice formation at valve seat Power assembly failure Loss of bulb charge Broken capillary	Check 4.6 Replace Replace 4.12
3.3.10 Heating Malfunction		
Insufficient heating	Dirty or plugged heater core Reheat coolant solenoid valve(s) malfunctioning or plugged Low coolant level Strainer(s) plugged Hand valve(s) closed Water pumps defective Auxiliary Heater malfunctioning.	Clean Check/Replace Check Clean Open Repair/Replace Repair/Replace
No Heating	Reheat coolant solenoid valve(s) malfunctioning or plugged Controller malfunction Pump(s) malfunctioning Safety device open	Check/Replace Replace Repair/Replace 1.11
Continuous Heating	Reheat coolant solenoid valve stuck open	Replace



SECTION 4
SERVICE

WARNING

Be sure to observe warnings listed in the safety summary in the front of this manual before performing maintenance on the hvac system

WARNING

Read the entire procedure before beginning work. Park the coach on a level surface, with parking brake applied. Turn main electrical disconnect switch to the off position.

NOTE

Following completion of all maintenance or service activities, the alarm queue should be cleared of any original alarms and any alarms generated during service. Refer to paragraph 3.2.1

NOTE

To avoid damage to the earth's ozone layer, use a refrigerant recovery system whenever removing refrigerant. When working with refrigerants you must comply with all local government environmental laws.

4.1 MAINTENANCE SCHEDULE

SYSTEM		SYSTEM	REFERENCE SECTION
ON	OFF		
a. Daily Maintenance			
X	X	Pre-trip Inspection - after starting Check tension and condition of V-belt	2.2 None
b. Weekly Inspection			
	X	Perform daily inspection	See above
	X	Check condenser, evaporator coils and air filters for cleanliness	None
	X	Check refrigerant hoses and compressor shaft seal for leaks	4.5
X		Feel filter-drier for excessive temperature drop across drier	4.10
c. Monthly Inspection and Maintenance			
	X	Perform weekly inspection and maintenance	See above
	X	Clean evaporator drain pans and hoses	None
	X	Check wire harnesses for chafing and loose terminals	Replace/Tighten
	X	Check electrical connections for cleanliness, tightness and serviceability	Clean/Tighten
	X	Check fan motor bearings	None
	X	Check compressor mounting bolts for tightness	None
	X	Check fan motor brushes	None
d. Yearly Inspection and Maintenance			
	X	Check and drain shaft seal reservoir	4.14.1

4.2 SUCTION AND DISCHARGE SERVICE VALVES

The suction and discharge service valves (Figure 4-1) are provided with a double seat and a gauge port, which allows servicing of the compressor and refrigerant lines.

Turning the valve stem counterclockwise (all the way out) will *backseat* the valve to open the line to the compressor and close off the gauge port. In normal operation, the valve is backseated to allow full flow through the valve. The valve should always be backseated before removing the service port/access valve cap.

Turning the valve stem clockwise (all the way forward) will *frontseat* the valve to isolate the compressor line and open the service port/access valve .

To measure suction or discharge pressure, midseat the valve by opening the valve clockwise 1/4 to 1/2 turn. With the valve stem midway between frontseated and backseated positions, the suction or discharge gauge port is open to both the compressor and the line.

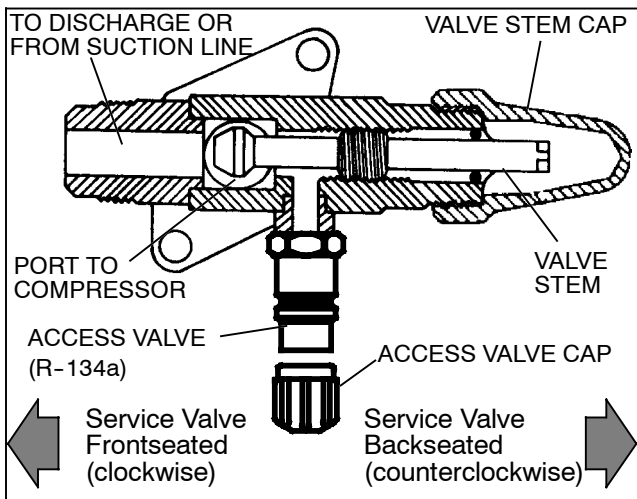

Figure 4-1. Suction or Discharge Service Valve

4.3 MANIFOLD GAUGE SET

A manifold gauge set (Figure 4-2) can be used to determine system operating pressures, add charge, equalize or evacuate the system.

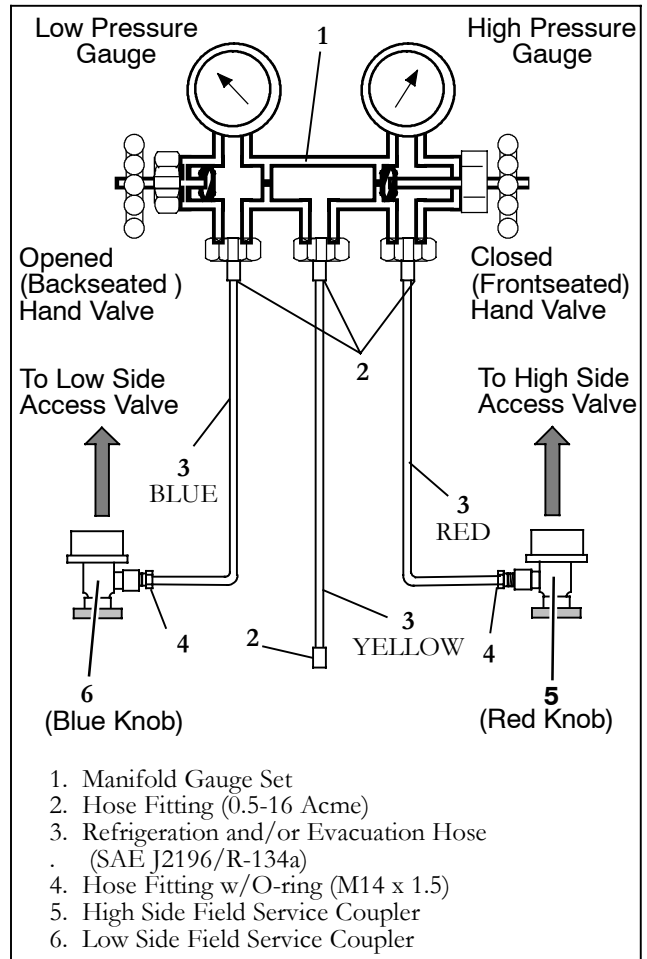

Figure 4-2. Manifold Gauge Set (R-134a)

4.3.1 Installing R-134a Manifold Gauge Set

A R-134a manifold gauge/hose set with self-sealing hoses is required for service of models covered within this manual. The manifold gauge/hose set is available from Mobile Climate Control. (Mobile Climate Control P/N 07-00294-00, which includes items 1 through 6, Figure 4-2.) To perform service using the manifold gauge/hose set, do the following:

a. Preparing Manifold Gauge/Hose Set For Use

1. If the manifold gauge/hose set is new or was exposed to the atmosphere it will need to be evacuated to remove contaminants and air as follows:
2. Back seat (turn counterclockwise) both field service couplers (see Figure 4-2) and midseat both hand valves.
3. Connect the yellow hose to a vacuum pump and an R-134a cylinder.
4. Evacuate to 10 inches of vacuum and then charge with R-134a to a slightly positive pressure of 1.0 psig.



5. Front seat both manifold gauge set hand valves and disconnect from cylinder. The gauge set is now ready for use.

b. Connecting Manifold Gauge/Hose Set

To connect the manifold gauge/hose set for reading pressures, do the following:

1. Remove service valve stem cap and check to make sure it is backseated. Remove access valve cap.
2. Connect the field service coupler (see Figure 4-2) to the access valve.
3. Turn the field service coupling knob clockwise, which will open the system to the gauge set.
4. Read system pressures.
5. Repeat the procedure to connect the other side of the gauge set.

c. Removing the Manifold Gauge Set

1. While the compressor is still ON, backseat the high side service valve.
2. Midseat both hand valves on the manifold gauge set and allow the pressure in the manifold gauge set to be drawn down to low side pressure. This returns any liquid that may be in the high side hose to the system.



To prevent trapping liquid refrigerant in the manifold gauge set be sure set is brought to suction pressure before disconnecting.

3. Backseat the low side service valve. Backseat both field service couplers and frontseat both manifold set hand valves. Remove the couplers from the access valves.
4. Install both service valve stem caps and access valve caps (finger-tight only).

4.4 PUMPING THE SYSTEM DOWN OR REMOVING THE REFRIGERANT CHARGE

NOTE

To avoid damage to the earth's ozone layer, use a refrigerant recovery system whenever removing refrigerant.

4.4.1 System Pump Down For Low Side Repair

To service or replace the filter-drier, thermostatic expansion valve, suction line, liquid line solenoid valve or evaporator coil, pump the refrigerant to the condenser and receiver as follows:

- a. Install manifold gauge set to the filter-drier inlet service valve. Refer to Figure 4-3.

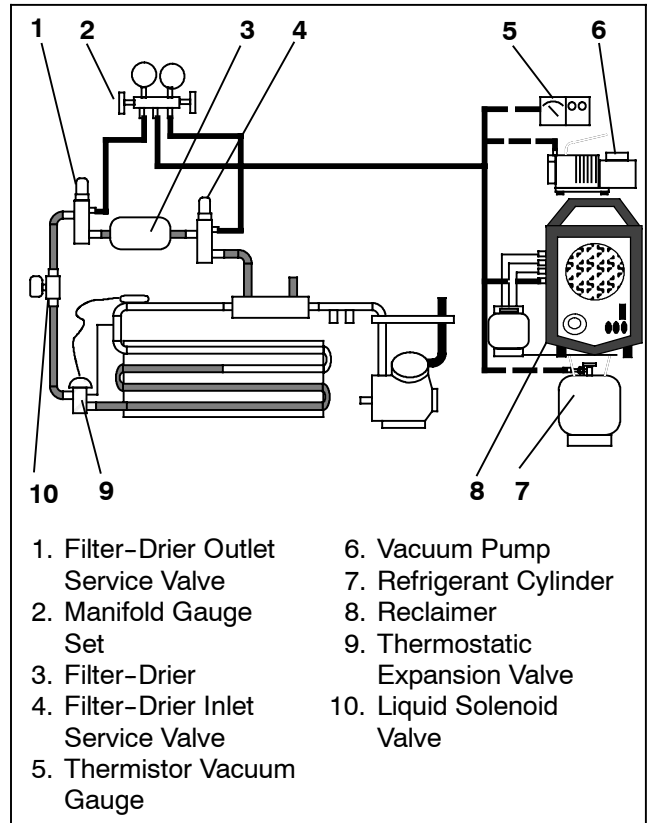

Figure 4-3. Low Side Pump Down Connections

- b. Frontseat the filter-drier inlet service valve by turning clockwise. Disconnect suction pressure transducer, install a jumper on the compressor mounted low pressure switch.
- c. Start the system and run in cooling. Stop the unit when suction reaches a slight vacuum (1-2 ”/hg).
- d. Frontseat the compressor suction service valve to trap refrigerant in the high side of the system between the compressor suction service valve and the filter-drier inlet valve. Wait 5 minutes to verify that system remains in a vacuum. If system pressure rises above a vacuum, open the compressor suction service valve and repeat steps c. and d. until the system remains in a vacuum.
- e. Service or replace necessary components.
- f. Leak check connections and replace filter-drier. Refer to paragraph 4.5.



- g. Energize the Liquid Line Solenoid Valve (LSV) using an external power source (24 VDC).
- h. Using refrigerant hoses designed for vacuum service, evacuate and dehydrate the low side of the system by connecting a vacuum pump to the center connection of manifold gauge set. Evacuate system to 500 microns. Close off pump valve, isolate vacuum gauge and stop pump. Wait 5 minutes to verify that vacuum holds.
- i. Recharge low side with R-134a to 20 to 30 psig by admitting vapor from the refrigerant cylinder.
- j. Re-connect the suction pressure transducer and remove the low pressure switch jumper. If required, clear any alarms that have been generated during this procedure.
- k. Open service valves and check refrigerant level. Refer to paragraph 4.7.1.

4.4.2 Refrigerant Removal From An Inoperative Compressor.

To remove the refrigerant from a compressor that is not operational, do the following:

- a. Attach a manifold gauge set as shown in Figure 4-4 and isolate the compressor by front seating the suction and discharge valves.
- b. Recover refrigerant with a refrigerant reclaimer. If the discharge service valve port is not accessible, it will be necessary to recover refrigerant through the suction service valve port only.
- c. Service or replace components as required and leak check the compressor.
- d. Using refrigerant hoses designed for vacuum service, connect a vacuum pump to center connection of manifold gauge set. Evacuate system to 500 microns. Close off pump valve, isolate vacuum gauge and stop pump. Wait 5 minutes to verify that vacuum holds.
- e. Once vacuum is maintained, recharge low side with R-134a to 20 to 30 psig by admitting vapor from the refrigerant cylinder. Backseat compressor service valves and disconnect manifold gauge set.
- f. Check refrigerant level. Refer to paragraph 4.7.1. It may be necessary to clear any alarms that have been generated.

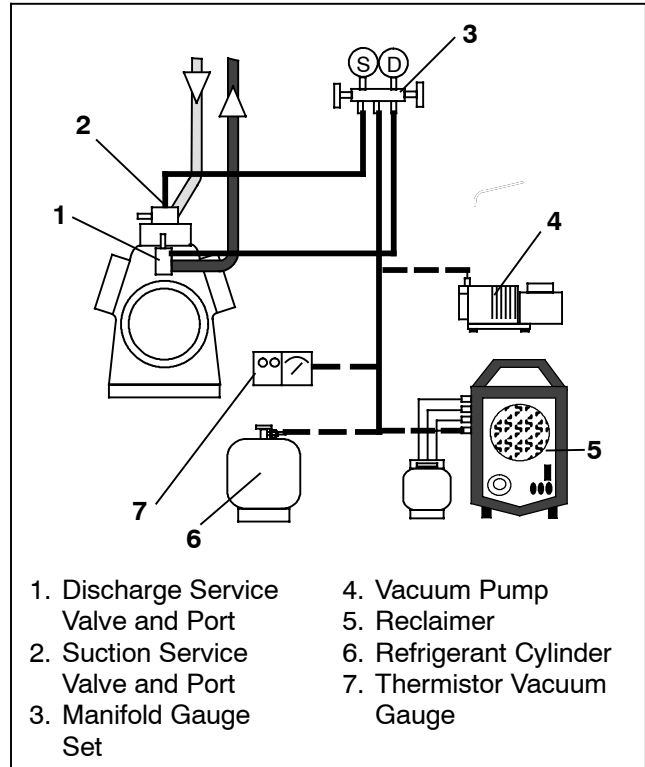

Figure 4-4. Compressor Service Connections

4.4.3 Pump Down An Operable Compressor For Repair

To service an operable compressor, pump the refrigerant into the condenser coil and receiver as follows:

- a. Install manifold gauge set. Refer to Figure 4-4.
- b. Frontseat the compressor suction service valve by turning clockwise.
- c. Install a jumper on the compressor mounted low pressure switch. Start the unit and run in cooling until 10 ”/hg (25.4 cm/hg) of vacuum is reached. Shut the system down and tag out system power source.
- d. Frontseat the compressor discharge service valve and wait 5 minutes to verify that vacuum is maintained. If the pressure rises above vacuum, open the compressor discharge service valve and repeat steps c and d until a vacuum is maintained.
- e. Service or replace components as required and leak check the compressor.
- f. Using refrigerant hoses designed for vacuum service, connect a vacuum pump to the center connection of the manifold gauge set. Evacuate system to 500 microns. Close off pump valve, isolate vacuum gauge and stop pump. Wait 5 minutes to verify that vacuum holds.



- g. Once vacuum is maintained, re-connect low pressure switch. Backseat compressor service valves and disconnect manifold gauge set.
- h. Check refrigerant level. Refer to paragraph 4.7.1. It may be necessary to clear any alarms that have been generated.

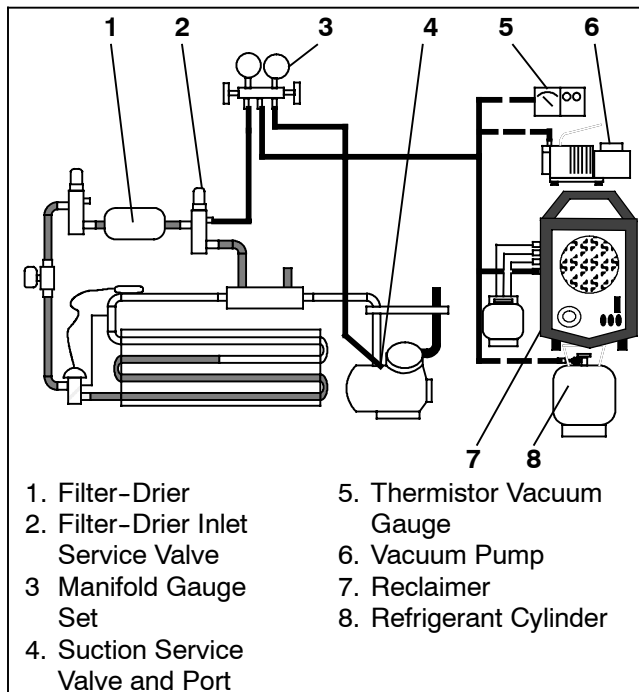

Figure 4-5. System Charge Removal Connections

4.4.4. Removing Entire System Charge

To remove the entire refrigerant charge, do the following:

- a. Connect a manifold gauge set to the system as shown in Figure 4-5.
- b. Connect a reclaimer to the center manifold gauge set connection.
- c. Recover refrigerant in accordance with reclaimer manufacturers instructions.

4.5 REFRIGERANT LEAK CHECK

A refrigerant leak check should always be performed after the system has been opened to replace or repair a component.

To check for leaks in the refrigeration system, perform the following procedure:

NOTE

It must be emphasized that only the correct refrigerant should be used to pressurize the system. Use of any other refrigerant will contaminate the system, and require additional evacuation.

- a. Ensure the service valves are open and power the liquid line service valve from an external source.
- b. If system is without refrigerant, charge system with refrigerant vapor to build up pressure to approximately 30 psig.
- c. Add sufficient nitrogen to raise system pressure to 150 to 200 psig (10.21 to 13.61 bar).
- d. Check for leaks. The recommended procedure for finding leaks in a system is with an electronic leak detector. Testing joints with soap suds is satisfactory and may be necessary under conditions when an electronic leak detector will not function correctly.
- e. Remove test gas and replace filter-drier.
- f. Evacuate and dehydrate the system. (Refer to paragraph 4.6.)
- g. Charge the unit. (Refer to paragraph 4.7.)
- h. Ensure that a Logic Board self-test has been performed and that there are no errors or alarms indicated. (Refer to paragraph 2.1.3.)

4.6 EVACUATION AND DEHYDRATION

4.6.1 General

The presence of moisture in a refrigeration system can have many undesirable effects. The most common are copper plating, acid sludge formation, “freezing-up” of metering devices by free water, and formation of acids, resulting in metal corrosion. A triple evacuation (Refer to paragraph 4.6.3) should be performed after a major system repair (compressor, evaporator, or condenser replacement). A one time evacuation (Refer to paragraph 4.6.4) should take place after a minor system repair (replacement of a solenoid valve or a filter drier).

4.6.2 Preparation

NOTE

Using a compound gauge for determination of vacuum level is not recommended because of its inherent inaccuracy.



NOTE

Never evacuate an open drive compressor below 500 microns.

- a. Evacuate and dehydrate only after pressure leak test. (Refer to paragraph 4.5)
- b. Essential tools to properly evacuate and dehydrate any system include a good vacuum pump with a minimum of 6 cfm ($10.2\ m^3/hr$) volume displacement, (MCC P/N 07-00176-11), and a good vacuum indicator (MCC P/N 07-00414-00).
- c. Keep the ambient temperature above 60°F (15.6°C) to speed evaporation of moisture. If ambient temperature is lower than 60°F (15.6°C), ice may form before moisture removal is complete.

4.6.3 Procedure for Evacuation and Dehydrating System (Triple Evacuation)

- a. Remove refrigerant using a refrigerant recovery system. Refer to paragraph 4.4.4
- b. The recommended method is connecting lines ($3/8''$ OD copper tubing or refrigerant hoses designed for vacuum service) as shown in Figure 4-5.
- c. Make sure vacuum pump valve is open.
- d. Start vacuum pump. Slowly open valves halfway and then open vacuum gauge valve.
- e. Evacuate unit until vacuum gauge indicates 2000 microns Hg vacuum. Close gauge valve, vacuum pump valve, and stop vacuum pump.
- f. Break the vacuum with dry nitrogen. Raise system pressure to approximately 2 psig.
- g. Purge the nitrogen from the system.
- h. Repeat steps d. thru g. one time.
- i. Start vacuum pump and open all valves. Dehydrate unit to 500 microns Hg vacuum.
- j. Close off pump valve, and stop pump. Wait five minutes to see if vacuum holds.
- k. Charge system. Refer to paragraph 4.7.2

4.6.4 Procedure for Evacuation and Dehydrating System (One Time Evacuation)

- a. Remove refrigerant using a refrigerant recovery system. Refer to paragraph 4.4.4
- b. The recommended method is connecting lines ($3/8''$ OD copper tubing or refrigerant hoses designed for vacuum service) as shown in Figure 4-5.
- c. Make sure vacuum pump valve is open.

- d. Start vacuum pump. Slowly open valves halfway and then open vacuum gauge valve.
- e. Evacuate unit until vacuum gauge indicates 500 microns Hg vacuum.
- f. Close off pump valve, and stop pump. Wait five minutes to see if vacuum holds.
- g. Charge system. Refer to paragraph 4.7.2

4.7 ADDING REFRIGERANT TO SYSTEM

4.7.1 Checking Refrigerant Charge

The following conditions must be met to accurately check the refrigerant charge.

- a. Coach engine operating at high idle.
- b. Unit operating fully loaded (six cylinder) in cool mode for 15 minutes.
- c. Compressor discharge(head) pressure to 150 psig. (It may be necessary to block condenser air flow to raise discharge pressure.)
- d. Under the above conditions, the system is properly charged when the refrigerant liquid level is at $1/2$ to $3/4$ of the lower receiver sight glass. If it is not at the proper level, add or remove refrigerant to bring it to the proper level. *Refrigerant level should not appear in the upper sight glass, as this would indicate an overcharge.*

4.7.2 Adding Full Charge

- a. Install manifold gauge set at the compressor suction service valve and filter-drier inlet service valve. See figure Figure 4-5.
- b. Evacuate and dehydrate system. (Refer to paragraph 4.6)
- c. Place appropriate refrigerant cylinder on scales. Prepare to charge liquid refrigerant by connect charging hose from container to center connection on gage manifold . Purge air from hoses.
- d. Note weight of refrigerant and cylinder.
- e. Open cylinder valve, backseat discharge valve on gauge manifold and allow liquid refrigerant to flow into the high side of the system
- f. When correct charge has been added, refer to paragraph 1.7, close cylinder valve and frontseat manifold discharge valve. At this point, the high side of the system has been charged but the low side is still in a vacuum because the liquid line solenoid is normally closed.



- g. Prepare the cylinder as required to allow vapor charging. Backseat the manifold suction valve and charge vapor to build 30 psig pressure on the manifold suction gauge. Close cylinder valve and front-seat suction manifold set.
- h. Check charge level in accordance with the procedures of paragraph 4.7.1.

4.7.3 Adding Partial Charge

- a. Install manifold gauge set at the compressor suction service valve and filter-drier inlet service valve. See figure Figure 4-5.
- b. Place appropriate refrigerant cylinder on scale. Prepare to charge vapor refrigerant by connecting charging hose from container to center connection on gauge manifold. Purge air from hoses.
- c. Run the unit in the cool mode as described in section 4.7.1. With the suction service valve mid-seated, open the refrigerant cylinder valve and add vapor charge until the refrigerant level appears in the lower receiver sight glass. Under the above conditions, the system is properly charged when the refrigerant liquid level is at 1/2 to 3/4 of the lower receiver sight glass. If it is not at the proper level, add or remove refrigerant to bring it to the proper level. *Refrigerant level should not appear in the upper sight glass, as this would indicate an overcharge.*
- d. Backseat the suction service valve. Close the vapor valve on the refrigerant drum and note weight. Remove the manifold gauge set and replace all valve caps.

4.8 CHECKING FOR NONCONDENSIBLES

To check for noncondensibles, proceed as follows:

- a. Stabilize system to equalize pressure between the suction and discharge side of the system.
- b. Check temperature at the condenser and receiver.
- c. Check pressure at the filter-drier inlet service valve.
- d. Check saturation pressure as it corresponds to the condenser/receiver temperature using the Temperature-Pressure Chart, Table 4-4.
- e. If gauge reading is 3 psig (0.20 bar) or more than the saturation pressure in step d, noncondensibles are present.
- f. Remove refrigerant using a refrigerant recovery system.
- g. Evacuate and dehydrate the system. (Refer to paragraph 4.6.)

- h. Charge the unit. (Refer to paragraph 4.7.2.)

4.9 CHECKING AND REPLACING HIGH OR LOW PRESSURE SWITCH



Do not use a nitrogen cylinder without a pressure regulator



Do not use oxygen in or near a refrigeration system as an explosion may occur.

- a. Disconnect wiring and remove switch from unit. All units are equipped with a schrader valve at the pressure switch connections.
- b. Connect switch to a cylinder of dry nitrogen. (See Figure 4-6.)

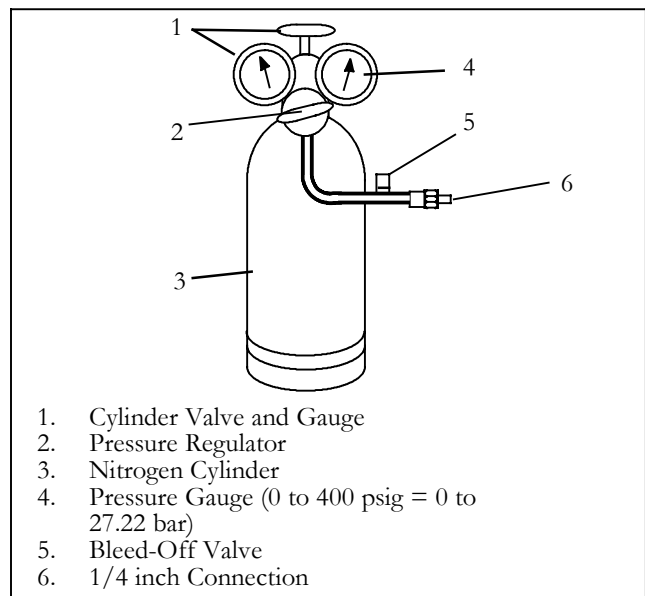

Figure 4-6. Checking High Pressure Switch

- c. Connect an ohmmeter across switch terminals.
- d. Set nitrogen pressure regulator higher than the upper switch setting. (refer to paragraph 1.7.)
- e. For a high pressure switch, close cylinder valve and open bleed-off valve. Open cylinder valve and slowly close bleed-off valve. The switch should open, (no continuity) with in required cut out tolerance. Close cylinder valve and release pressure through the bleed-off valve. As pressure drops, switch should close, (continuity) within required cut in tolerance.



- f. For a low pressure switch, close cylinder valve and bleed-off valve. Open cylinder valve to bring pressure above the cutout setting. Close the cylinder valve and slowly open bleed-off valve. The switch should open (no continuity), with in required cut out tolerance. Open cylinder valve and increase pressure by closing the bleed-off valve. As pressure increases, switch should close (continuity), within required cut in tolerance.
- g. Replace or re-install switch (as required) and re-connect wiring.

4.10 FILTER-DRIER

4.10.1 To Check Filter-Drier

The filter-drier (see Figure 4-7) must be changed if the drier is partially restricted or service has been performed on the refrigerant system. Check for a restriction by feeling the inlet and outlet lines of the filter-drier. If the outlet side feels cooler than the inlet side, then the filter-drier should be changed

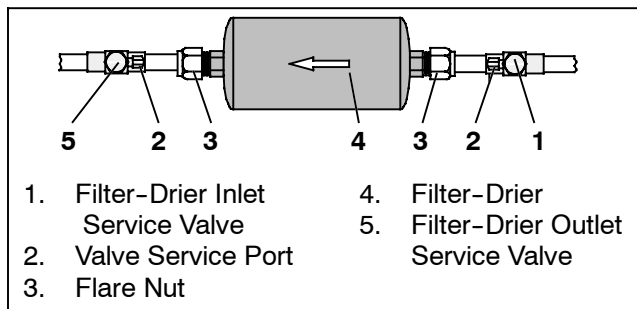

Figure 4-7. Filter-Drier Removal

4.10.2 To Replace Filter-Drier

- a. Perform a low side pump down. Refer to paragraph 4.4.1. (steps a. to c.)
- b. Turn the driver's A/C switch to "OFF" position.
- c. Frontseat the filter-drier outlet service valve and place a new filter-drier near the unit for immediate installation.
- d. Remove two screws securing the filter-drier clamp. Remove the filter-drier clamp.



The filter-drier may contain liquid refrigerant. Slowly loosen the flare nuts to

avoid refrigerant contact with exposed skin or eyes.

- e. Using two open end wrenches, slowly crack open the flare nuts on each side of the filter-drier. Remove the filter-drier.
- f. Remove seal caps from the new filter-drier. Apply a light coat of compressor oil to the flares.
- g. Assemble the new filter-drier to lines ensuring that the arrow on the body of the filter-drier points in the direction of the refrigerant flow (refrigerant flows from the receiver to the evaporator). Finger tighten flare nuts.
- h. Tighten filter-drier flare nuts using two open end wrenches.
- i. Evacuate the filter-drier and lines by connecting a vacuum pump as shown in Figure 4-3. Evacuate to 500 microns.
- j. Backseat (fully close) both service valve ports and replace valve caps.
- k. Test filter-drier for leaks.
- l. Check refrigerant level.

4.11 SERVICING THE LIQUID LINE SOLENOID VALVE

The Liquid line solenoid valve (Figure 4-8) is very similar to the reheat coolant valve. It requires no maintenance unless a malfunction to the internal parts or coil occurs. This may be caused by foreign material such as: dirt, scale, or sludge in the refrigeration system, or improper voltage to the coil.

There are only three possible valve malfunctions: coil burnout, failure to open, or failure to close.

Coil burnout may be caused by the following:

- 1. Improper voltage.
- 2. Continuous over-voltage, more than 10% or under-voltage of more than 15%.
- 3. Incomplete magnet circuit due to the omission of the coil housing or plunger.
- 4. Mechanical interface with movement of plunger which may be caused by a deformed enclosing tube.

Failure to open may be caused by the following:

- 1. Coil burned out or an open circuit to coil connections.
- 2. Improper voltage.
- 3. Defective plunger or deformed valve body assembly.



Failure to close may be caused by the following:

- 1 Defective plunger or deformed valve body assembly.
- 2 Foreign material in the valve.

4.11.1 Coil Replacement

- a. It is not necessary to remove the refrigerant charge from the system.
- b. Place main battery disconnect switch in OFF position and lock.
- c. Disconnect wire leads to coil.
- d. Remove coil retaining clip and nameplate.
- e. Lift burned-out coil from enclosing tube and replace.
- f. Connect wire leads and test operation

4.11.2 Internal Part Replacement

- a. Perform a low side pump down. Refer to paragraph 4.4.1.
- b. Carefully loosen enclosing tube assembly and ensure no pressure remains within the valve. Disassemble valve and replace defective parts.
- c. Assemble valve and leak check.
- d. Evacuate low side and re-open system.

4.11.3. Replace Entire Valve

- a. Perform a low side pump down, refer to paragraph 4.4.1. Remove coil and plunger assembly and unbrazed valve from lines.
- b. Remove valve assembly from bracket.
- c. Disassemble new valve, to protect internal parts, and solder to lines.
- d. Assemble and leak check valve.
- e. Evacuate low side and re-open system.
- f. Connect wire leads and test operation.

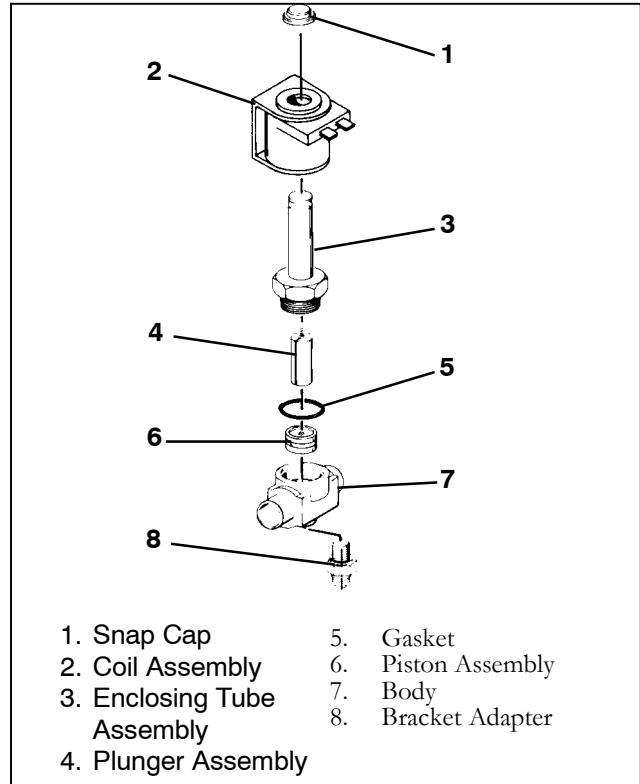

Figure 4-8. Liquid Line Solenoid Valve

4.12 THERMOSTATIC EXPANSION VALVE

The thermostatic expansion valve (TXV) (Figure 4-9) is an automatic device which maintains constant superheat of the refrigerant gas leaving the evaporator regardless of suction pressure. The valve functions are: (a) automatic control of refrigerant flow to match the evaporator load and (b) prevention of liquid refrigerant entering the compressor. Unless the valve is defective, it seldom requires any maintenance.

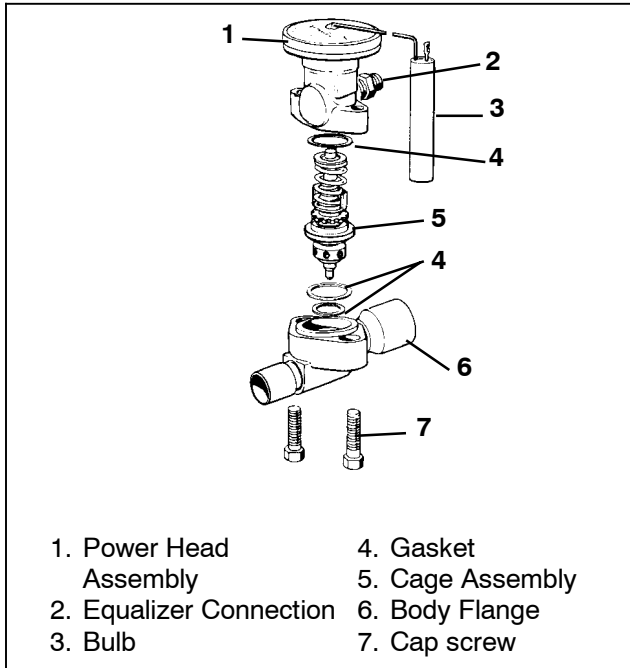

Figure 4-9. Thermostatic Expansion Valve

4.12.1 Valve Replacement

- a. Pump down low side of the unit. (Refer to paragraph 4.4.1)
- b. Remove insulation from expansion valve bulb. (See Figure 4-9 and Figure 4-10.)
- c. Loosen retaining straps holding bulb to suction line and detach bulb from the suction line.
- d. Loosen flare nuts on equalizer line and disconnect equalizer line from the expansion valve.
- e. Remove capscrews and lift off power head and cage assemblies and gaskets.
- f. Check, clean and remove any foreign material from the valve body, valve seat and mating surfaces. If required, replace valve body.

NOTE

R-134a TXV's are non-adjustable.

- g. Using new gaskets, install new cage and power head assemblies.
- h. Fasten equalizer line to the expansion valve.
- i. Leak check the new valve and evacuate and dehydrate low side. (Refer to paragraph 4.6.)

- j. The thermal bulb is installed below the center of the suction line (four or eight o'clock position). This area must be clean to ensure positive bulb contact. Strap thermal bulb to suction line. Ensure that retaining straps are tight and renew insulation.
- k. If required, add vapor refrigerant to bring low side pressure to 20 to 30 psig. Open filter-drier inlet service valve and compressor service valves.
- l. Run the coach for approximately 30 minutes on fast idle.
- m. Check refrigerant level. (Refer to paragraph 4.7.1)
- n. Check superheat. (Refer to paragraph 4.12.2.)

4.12.2 Superheat Measurement

NOTE

All readings must be taken from the TXV bulb location and out of the direct air stream.

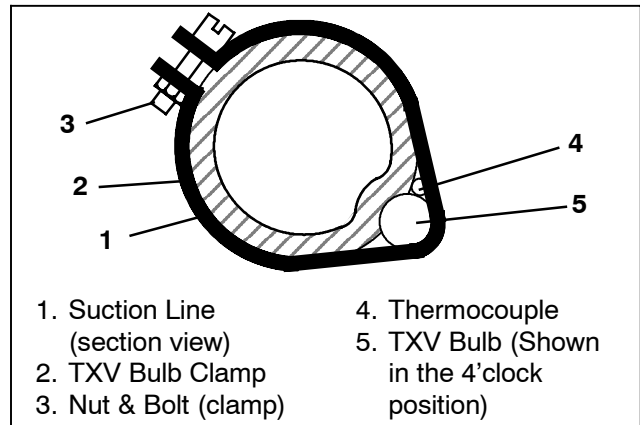

Figure 4-10. Thermostatic Expansion Valve Bulb and Thermocouple

- a. Remove Presstite insulation from expansion valve bulb and suction line.
- b. Loosen one TXV bulb clamp and make sure area under clamp is clean.
- c. Place temperature thermocouple in contact with the suction tube and parallel to the TXV bulb, and then secure loosened clamp making sure both bulb and thermocouple are firmly secured to suction line. (See Figure 4-10.) Reinstall insulation around the bulb.
- d. Connect an accurate low pressure gauge to the low pressure port (Figure 1-9, 22).
- e. Start bus and run on fast idle until unit has stabilized, about 20 to 30 minutes.



NOTE

When conducting this test, the suction pressure must be at least 6 psig (0.41 bar) below the expansion valve maximum operating pressure (MOP). Refer to paragraph 1.7 for MOP.

- f. Using the temperature/pressure chart (Table 4-4), determine the saturation temperature corresponding to the evaporator outlet pressure.
- g. Note the temperature of the suction gas at the expansion valve bulb. Subtract the saturation temperature from this temperature. The difference is the superheat of the suction gas.
- h. The superheat may cycle from a low to high reading. Monitor the superheat taking readings every 3-5 minutes for a total of 5-6 readings. Calculate the superheats, add the readings and divide by the number of readings taken to determine average superheat. Refer to paragraph 1.7 for superheat setting.
- i. If superheat is not within tolerance, replace the valve.

4.13 REPLACING RETURN AIR FILTERS

The return air filters are located behind the return air grill, inside the vehicle.

The filters should be checked for cleanliness periodically depending on operating conditions. A dirty filter will restrict air flow over the evaporator coil which may cause insufficient cooling or heating and possible frost buildup on the coil. To remove the filters, do the following.

- a. Place main battery disconnect switch in OFF position and lock.
- b. Remove the return air grille.
- c. Loosen filter retaining hardware and remove the filter from the grille.
- d. Reverse procedure to install new filters.

4.14 COMPRESSOR MAINTENANCE

4.14.1 Shaft Seal Reservoir

If compressor is fitted with a shaft seal reservoir, it is recommended that the reservoir is serviced (checked and drained) at least once a year. Refer to the 05G

Twin Port Workshop Manual 62-11052 for complete instructions.

4.14.2 Removing the Compressor

If compressor is inoperative and the unit still has refrigerant pressure, isolate the compressor and remove the refrigerant. Refer to paragraph 4.4.2. If compressor is operative, perform a pump down. Refer to paragraph 4.4.3.

- a. Place main battery disconnect switch in OFF position and lock.
- b. Tag and disconnect wiring to the high pressure and low pressure switch, unloaders and clutch.
- c. Remove tension on drive belts, remove drive belts.
- d. Loosen bolts at suction and discharge service valve flanges and break seal to be sure pressure is released. Remove bolts.
- e. Remove four bolts holding compressor to base
- f. Attach sling or other device to the compressor and remove compressor from the coach through the access door.

NOTES

- 1. Service replacement compressors are sold without service valves. Valve pads are installed in their place. The optional unloaders are not supplied, as the cylinder heads are shipped with plugs. The customer should retain the original unloader valves for use on the replacement compressor.
- 2. The piston plug that is removed from the replacement compressor head must be installed in the failed compressor if returning for warranty or core credit.
- 3. Do not interchange allen-head capscrews that mount the piston plug and unloader, they are not interchangeable.
- 4. Check oil level in service replacement compressor. (Refer to paragraphs 1.7 and 4.14.4.)

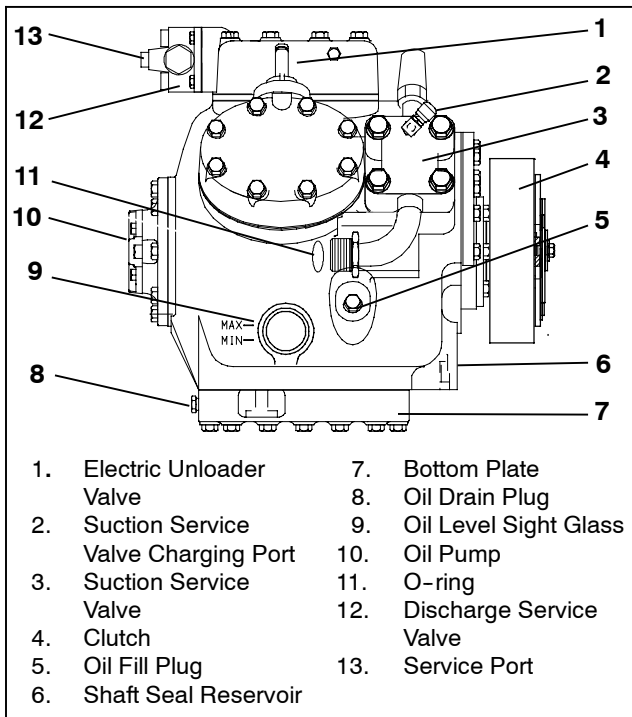

Figure 4-11. Compressors

g. Remove the three socket head capscrews from the cylinder head(s) that have unloader valves installed. See Figure 4-12. Remove the unloader valve and bypass piston assembly, keeping the same capscrews with the assembly. The original unloader valve must be transferred to the replacement compressor. The plug arrangement removed from the replacement is installed in the original compressor as a seal. If piston is stuck, it may be extracted by threading a socket head capscrew into top of piston. A small Teflon seat ring at the bottom of the bypass piston plug must be removed.

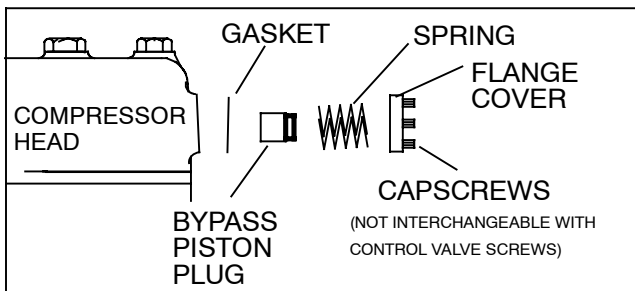

Figure 4-12. Removing Bypass Piston Plug

h. Remove the pressure switches and install on replacement compressor after checking switch operation (refer to paragraph 4.9).

- i. Remove clutch assemble and retain original clutch key. Install on replacement compressor.
- j. Install compressor in unit by performing the removal steps in reverse. It is recommended that new locknuts be used when replacing compressor. Install new gaskets on service valves and tighten bolts uniformly (55 to 80 ft-lbs suction and 20 to 30 ft-lbs discharge service valves).
- k. Leak check connections and replace filter-drier. Refer to paragraph 4.5.
- l. Using refrigerant hoses designed for vacuum service, connect a vacuum pump (see Figure 4-4) and evacuate compressor to 500 microns. Front seat both manifold valves to isolate the pump.
- m. Open compressor service valves.
- n. Start unit and check refrigerant level (refer to paragraph 4.7.1).
- o. Check compressor oil level (refer to paragraph 4.14.4). Add or remove oil if necessary.
- p. Check compressor unloader operation.(refer to paragraph 4.14.5)
- q. Backseat compressor service valves.
- r. Remove manifold gauge set.(refer to paragraph 4.3 or paragraph 4.3.1).

4.14.3 Transferring Compressor Clutch

To remove a clutch (see Figure 4-13) from a compressor and install on a replacement compressor, do the following:

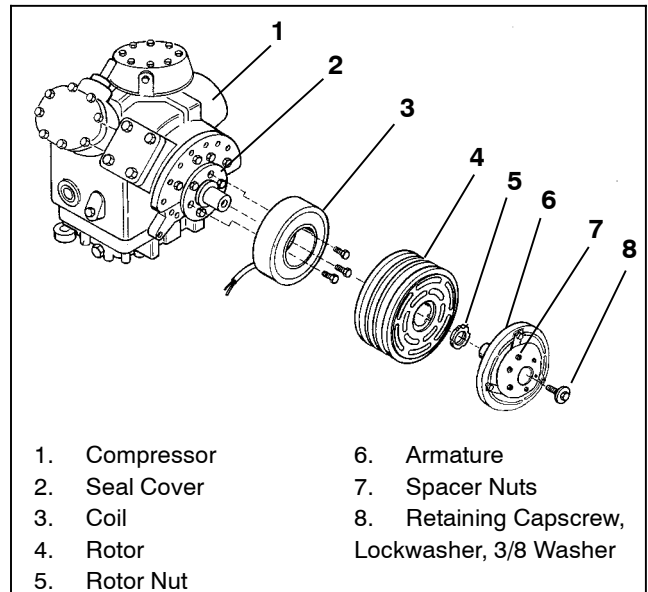

Figure 4-13. Compressor Clutch

- a. Place main battery disconnect switch in OFF position and lock.



- b. Tag and disconnect wiring to the clutch.
- c. Remove tension on drive belts, remove drive belts.
- d. Remove the armature as a complete assembly by removing the retaining capscrew, lockwasher, and special 3/8 washer from the compressor crankshaft. Use special tool (MCC P/N 07-00240-01) to prevent crankshaft rotation.
- e. Install a 7/8-14 x 4" (MCC P/N 07-00381-00) capscrew into the center hole of the armature assembly and use it as a jacking bolt to remove the armature. Use tool (MCC P/N 07-00240-01) as in step a. to prevent crankshaft rotation.
- f. Using special tool (MCC P/N 07-00242-01), remove the rotor nut and rotor. Retain original key.
- g. Noting the position of the wire, remove the three bolts holding the coil to the compressor.
- h. Remove every other bolt from the seal cover of the new compressor in the same manner as the original compressor. Mount the coil assembly with the wire in the same orientation as it was mounted on the original compressor. Tighten the mounting bolts to 45-50 ft/lbs (5.53-6.92 mkg).
- i. Mount the rotor on the shaft. Seat the rotor to the hub, using the rotor nut. Be sure pulley turns freely without binding. Tighten rotor nut by first noting torque necessary to start the nut on the hub and then adding 50 ft/lbs (6.92 mkg) of torque.
- j. Install armature on shaft using original key and tighten mounting bolt to 20 ft/lbs (2.8 mkg).
- k. Perform a check of the air gap between the inside face of the armature and the mating face of the rotor. The air gap should be measured with a minimum of 30 psig (2.04 bar) in the crankcase. A preliminary check may be performed before the crankcase is pressurized but a final check must be performed before the clutch is operated. The gap should be between 0.030 and 0.060 inch (7.62 to 15.24 mm).
- l. Loosen each of the three lock-nuts with a 7/16" box wrench while holding the jacking screws with a 1/8" hex socket wrench.
- m. Back off the three jacking screws until they do not touch the armature plate.
- n. Turn the jacking screws clock-wise until they make contact with the armature plate and then one and one half more turns after contact.
- o. Measure the initial clearance, the gap should be between .030" and .060". All three set screw locations should be very close in clearance dimensions.
- p. With the clearance set, hold each set screw while tightening the lock nuts to 7 ft/lbs.
- q. Reconnect wiring and test clutch operation.

4.14.4 Compressor Oil Level

To check, and if required correct, the compressor oil level do the following:

- a. Operate the coach for at least one-half hour at fast idle speed, with the temperature controls at the coolest setting, and the compressor fully loaded. It may be necessary to pre-heat the coach and/or operate the system in the reheat mode to keep the compressor fully loaded throughout this procedure
- b. Ensure the system is fully charged (refer to paragraph 4.7.1) and the compressor crankcase is warm to the touch after fifteen minutes of operation.
- c. Shut off the system and immediately record the oil level in the compressor sight glass. See Figure 4-11. If the compressor is not level, an average between the sight glass levels will have to be made to determine level.
- d. The correct oil level for this application should be between the bottom and 1/2 of the oil level sight-glass. See Figure 4-11. If the oil level is correct, release the coach into service. If the level is above the 1/2 sightglass maximum, proceed to step e. If the level is below the 1/2 sightglass maximum proceed to step f.
- e. To remove oil and bring the level to the 1/2 sight-glass maximum, do the following:
 - 1. With the system off, connect a manifold gauge set to the compressor suction and discharge service valves. Front seat the service valves to isolate the compressor from the system (See Figure 4-4) and reclaim the refrigerant to below atmospheric pressure. Shut off the reclaim and verify the pressure does not rise. If the pressure rises, continue reclaiming until the pressure remains below atmospheric.



WARNING

Extreme care must be taken to ensure that all the refrigerant has been removed from the compressor crankcase or the resultant pressure will forcibly discharge compressor oil.

2. Drain or pump out compressor oil until the level is brought to or just below the 1/2 sightglass maximum.
3. Evacuate the compressor to 500 microns. Backseat the compressor service valves and repeat the oil level check procedure.
- f. To add oil to the compressor, do the following:
 1. With the system off, connect a manifold gauge set to the compressor suction and discharge service valves. Front seat both service valves to isolate the compressor from the system (See Figure 4-4) and reclaim the refrigerant to below atmospheric pressure. Shut off the reclaiming and verify the pressure does not rise. If the pressure rises, continue reclaiming until the pressure remains below atmospheric.
 2. Add oil to compressor crankcase slowly, through the oil fill plug opening (see Figure 4-11) to bring level to mid range of allowed levels.
 3. Evacuate compressor to 500 microns. Backseat compressor suction and discharge valves, start system and recheck oil level.
 4. Remove manifold gauge set.

4.14.5 Checking Unloader Operation

To check unloader operation do the following:

- a. Install a manifold gauge set as shown in Figure 4-5. Ensure both manifold valves are frontseated and center connection is tight on blank fitting.
- b. Midseat compressor suction service valve.

- c. Disconnect the suction pressure transducer (Figure 1-9, 23). This will force the controller to energize the unloader(s).
- d. Start the bus and run in cooling, lower set point if required to ensure system remains in full speed cooling.
- e. Locate the unloader connector at the compressor. Observe manifold suction gauge while unplugging the connector. Pressure should decrease 3 to 5 psi (0.2 to 0.4 bar) when the unloader is unplugged and increase the same amount as the plug is reconnected. Repeat test for second unloader if fitted.
- f. If pressures do not react as described, check unloader coil or repair unloader mechanism as required.
- g. When testing is complete, reconnect transducer and unloader connectors and remove manifold gauge set.
- h. Disconnection of the suction pressure transducer will cause an "A15" alarm. Once the transducer is reconnected, the alarm will go to inactive and can then be cleared.

4.15 TEMPERATURE SENSOR CHECKOUT

- a. An accurate ohmmeter must be used to check resistance values shown in Table 4-1.
- b. Due to variations and inaccuracies in ohmmeters, thermometers or other test equipment, a reading within two percent of the chart value would be considered acceptable. If a sensor is bad, the resistance value would usually be much higher or lower than the value given in Table 4-1 .
- c. At least one sensor lead must be disconnected from the controller before any reading can be taken. Not doing so will result in a false reading. Two preferred methods of determining the actual test temperature at the sensor are an ice bath at 32°F (0°C) and/or a calibrated digital temperature meter.



Table 4-1. Temperature Sensor Resistance

Temperature		Resistance In Ohms
°F	°C	
-20	-28.9	165,300
-10	-23.3	117,800
0	-17.8	85,500
10	-12.2	62,400
20	- 6.7	46,300
30	- 1.1	34,500
32	0	32,700
40	4.4	26,200
50	10.0	19,900
60	15.6	15,300
70	21.1	11,900
77	25	10,000
80	26.7	9,300
90	32.2	7,300
100	37.8	5,800
110	43.3	4,700
120	48.9	3,800

4.16 PRESSURE TRANSDUCER CHECKOUT

NOTE

System must be operating to check transducers.

- a. With the system running use the driver display and manifold gauges to check suction and/or discharge pressure(s) simultaneously.
- b. Determine with the gages whether one or both pressure readouts are correct. If one is correct, exchange the pressure transducer locations. If the problem moves with the transducer replace the faulty transducer.
- c. If the driver display read out disagrees with both values shown on the manifold gauges proceed to step d.



Use care when checking/manipulating wires/plugs attached to the Logic Board.

Damage to the board or wiring harness can occur.

- d. Verify that the wiring to the transducer(s) is in good condition.
- e. Use a digital volt-ohmmeter to measure voltage across the transducer connector corresponding to terminals A & B. See Figure 4-14. The reading should be 5.0 VDC.
- f. Use a digital volt-ohmmeter to measure wire continuity between the connector positions corresponding to C and J6-23(Suction) or C and J6-20(Discharge). See Figure 1-6 or Figure 5-2.
- g. Use a digital volt-ohmmeter measure voltage across the transducer at terminals A & C. See Figure 4-14. Compare to values in Table 4-2. A reading within two percent of the values in the table would be considered good.

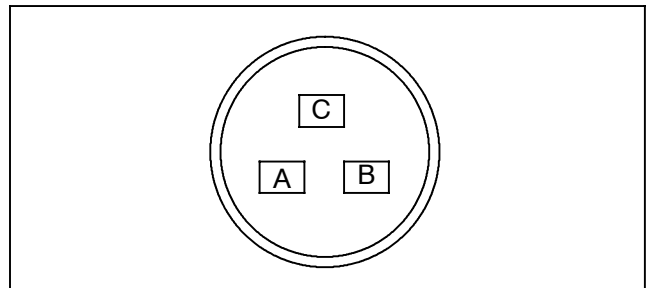

Figure 4-14 Transducer Terminal Location

4.17 REPLACING SENSORS AND TRANSDUCERS

- a. Place main battery disconnect switch in OFF position and lock.
- b. Tag and disconnect wiring from defective sensor or transducer.
- c. Remove and replace defective sensor or transducer. Sensor/transducer connections are fitted with Schreader valves to facilitate replacement.
- d. Connect wiring to replacement sensor or transducer.
- e. Checkout replacement sensor or transducer. (Refer to section 4.15 or 4.16, as applicable.)
- f. Repair or replace any defective component(s), as required.

Table 4-2. Pressure Transducer Voltage

"/hg	Voltage	Psig	Voltage	Psig	Voltage	Psig	Voltage	Psig	Voltage	Psig	Voltage
20"	0.369	40	0.858	95	1.397	150	1.936	205	2.475	260	3.014
10"	0.417	45	0.907	100	1.446	155	1.985	210	2.524	265	3.063
Psig	Voltage	50	0.956	105	1.495	160	2.034	215	2.573	270	3.112
0	0.466	55	1.007	110	1.544	165	2.083	220	2.622	275	3.161
5	0.515	60	1.054	115	1.593	170	2.132	225	2.671	280	3.210
10	0.564	65	1.103	120	1.642	175	2.181	230	2.720	285	3.259
15	0.614	70	1.152	125	1.691	180	2.230	235	2.769	290	3.308
20	0.663	75	1.204	130	1.740	185	2.279	240	2.818	295	3.357
25	0.712	80	1.250	135	1.789	190	2.328	245	2.867	300	3.406
30	0.761	85	1.299	140	1.838	195	2.377	250	2.916	305	3.455
35	0.810	90	1.348	145	1.887	200	2.426	255	2.965	310	3.504

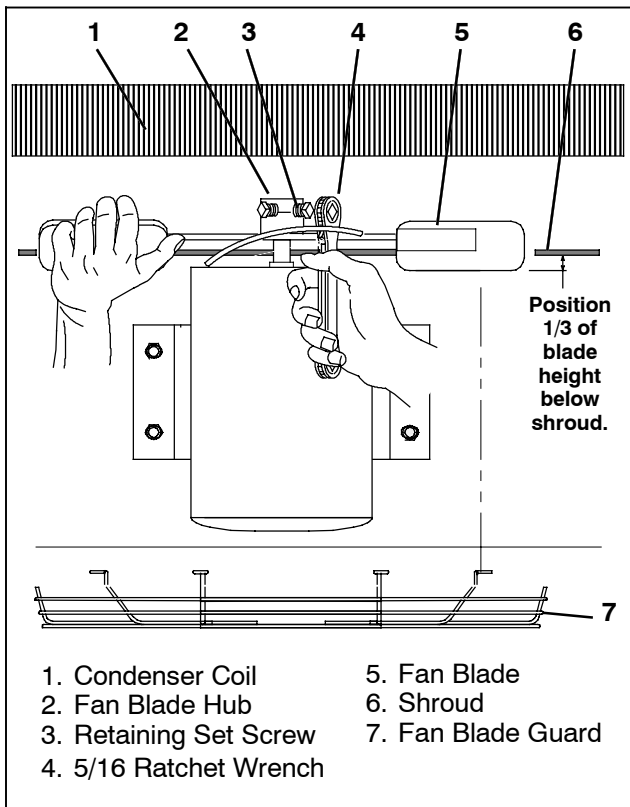
Figure 4-15. Condenser Fan Motor Removal (2 Fan)

4.18 REMOVING THE CONDENSER FAN MOTOR (2 FAN APPLICATIONS)

When removing or installing the condenser fan motor, care should be exercised to prevent any damage to the condenser coil.

- Place the main battery disconnect switch in the OFF position and lock.
- Disconnect the wire leads to the motor. Mark the leads for proper reassembly.
- Remove fan blade guard.
- Loosen the two retaining screws in the fan blade hub. The fan blade should remain on the shaft of the motor, but free to slide on the shaft of the motor .
- Remove the four motor mounting bolts securing the motor/motor mount to the unit. (refer to Figure 4-15)
- Remove the motor by sliding the motor down and out from the fan blade and unit. The fan blade should remain in the cavity between the condenser coil and fan shroud until the motor is free of the unit.
- When installing the motor, use an adhesive to secure the shaft key to the motor shaft or fan hub slot and apply an anti-seize compound to the motor shaft.
- Place the motor/motor mount back into position but leave the motor mounting bolts loose until the fan blade has been reinstalled on the motor shaft.
- Tighten the four motor mounting bolts. (refer to Figure 4-15)
- Position the fan blade 1/3 (the height of blade) below the shroud, tighten the two retaining screws in the fan hub.

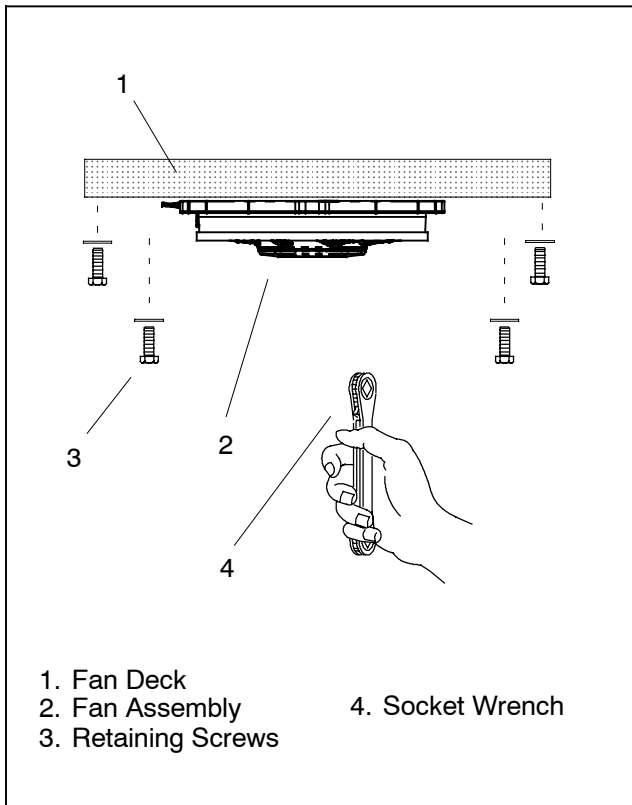

Figure 4-16. Condenser Fan Motor Removal (3 Fan)

NOTE

Condenser fan motor assemblies “pancake” style (part # Y45-00007-xx) , used on 3 fan application are not serviceable and should be replaced if failed.

4.19 REMOVING THE CONDENSER FAN MOTOR (3 FAN APPLICATIONS)

When removing or installing the condenser fan motor, care should be exercised to prevent any damage to the condenser coil.

- Place the main battery disconnect switch in the OFF position and lock.
- Disconnect the connector to the motor assembly.
- Remove the four (5mm) fan assembly mounting bolts securing the assembly to the unit. (refer to Figure 4-16)

- Remove the fan motor assembly.
- Re-install the fan motor assembly in the reverse order.

4.20 SERVICING THE EVAPORATOR FAN BLOWER MOTOR ASSEMBLY

4.20.1 Removing and Disassembling

- Place main battery disconnect switch in OFF position and lock.
- Disconnect the wire leads to the junction box of the motor. Mark the leads for proper reassembly.
- Remove motor mounting bolts (refer to Figure 4-17) to the bottom channel.
- Remove the venturi retaining clip mounting bolts securing the venturi ring. Slide the blower assembly with the venturi ring out of the blower housing.
- Loosen the two blower hub set screws to remove blower.
- To reassemble, apply an anti-seize compound to the motor shaft and reverse the above procedure. Position blower 1-1/16 inch from inside blower edge to venturi ring (See Figure 4-17).

4.20.2 Routine Examination and Cleaning

- At regular maintenance periods, remove brush covers and clean and examine motor interior.
- Remove all foreign material, such as dirt and carbon dust . Clean by vacuum if possible to avoid blowing foreign matter into the motor.
- Confirm free moving brushes to prevent binding.
- Examine brush wear and general condition. If brushes are broken, cracked, severely chipped, or worn to 1/3 the length of a new brush, replace them. Refer to section 4.20.3.
- Examine the condition of the brush springs. A discolored spring is a sign of overheating which may weaken the spring, in which case the spring should be replaced.
- Observe the condition of the commutator and the armature coils that are visible.

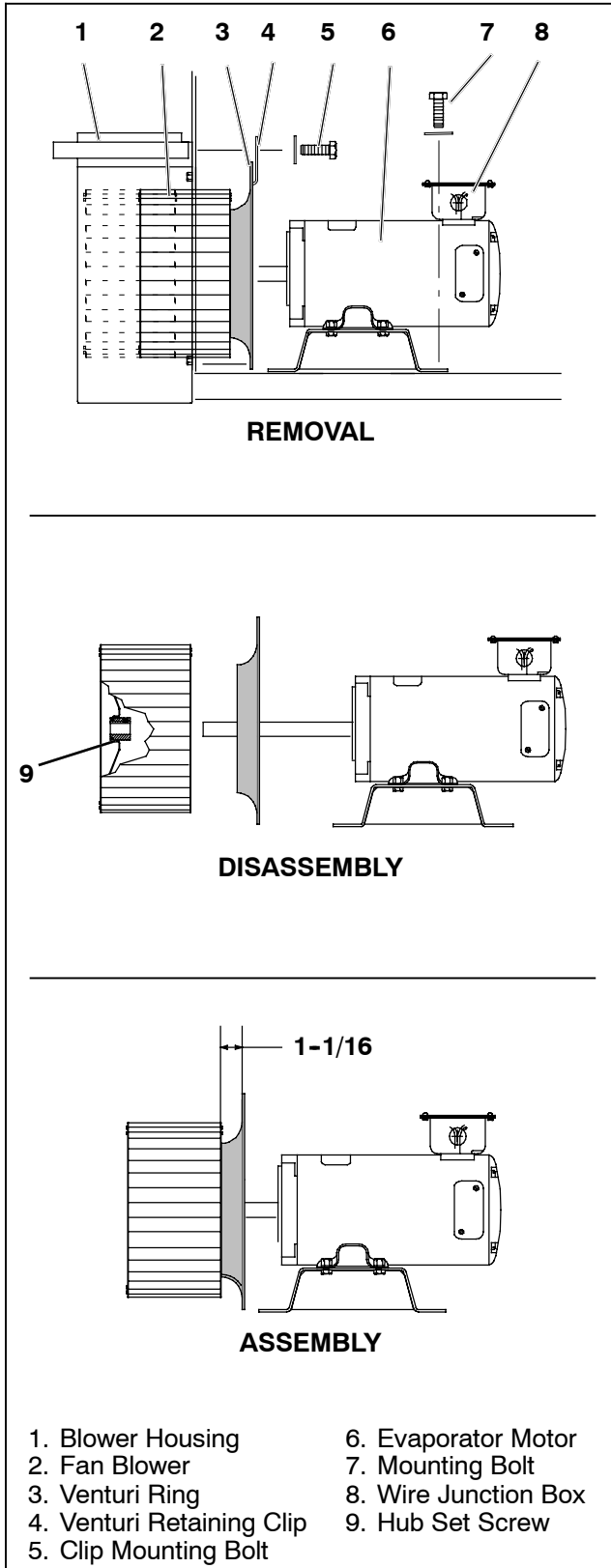

Figure 4-17. Evaporator Fan Blower Removal

4.20.3 Brush Replacement

If brushes are broken, cracked, severely chipped, or worn to 1/3 their original length, replace them.

- a. Remove brush covers.
- b. With fingers or suitable hook, lift the brush spring end up so the brush may slide up and out of the holder. Loosen the brush screw to remove the brush shunt terminal. Remove brush.
- c. To replace, lift brush spring and place brush in holder. Position spring end on top of the brush.
- d. Connect the brush shunt terminal to its proper crossover with the brush screw assembled loosely.
- e. Assure positioning of brush to permit the brush shunt to travel freely in the holder slot as the brush wears. If it hangs up, commutator damage and motor failure will result.
- f. Tighten screw.



4.21 SERVICING THE REHEAT COOLANT VALVE

The reheat coolant valve (RCV) requires no maintenance unless a malfunction of the internal parts or coil damage occurs. This may be caused by foreign material such as: dirt, scale, or sludge in the coolant system, or improper voltage to the coil.

Service of the valve may include replacement of the internal parts (see Figure 4-18) or replacement of the entire valve.

There are only three possible valve malfunctions: coil burnout, failure to open, or failure to close.

4.21.1 Reheat Coolant Valve Malfunctions

a. Coil burnout may be caused by:

1. Improper voltage.
2. Continuous over-voltage, more than 10% or under-voltage of more than 15%.
3. Incomplete magnetic circuit due to the omission of the coil housing or plunger.
4. Mechanical interference with movement of plunger which may be caused by a deformed enclosing tube.

b. Failure to open may be caused by:

1. Coil burned out or an open circuit to coil connections.
2. Improper voltage.
3. Torn diaphragm.
4. Defective plunger or deformed valve body assembly.

c. Failure to close may be caused by:

1. Defective plunger or deformed valve body assembly.
2. Foreign material in the valve.

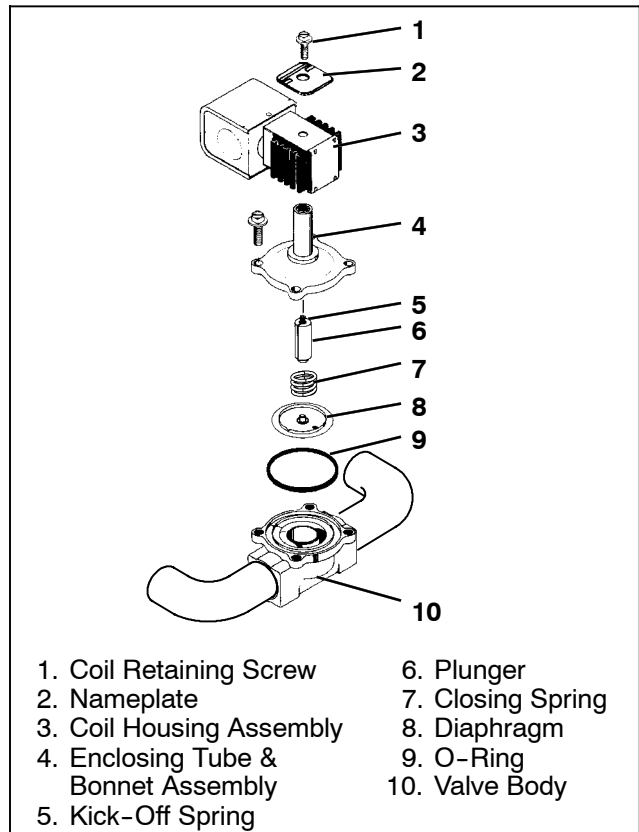

Figure 4-18. Reheat Coolant Valve Assembly

4.21.2 Replacing the Coil

NOTE

It is not necessary to drain the coolant from the system.

- a. Place the rear control switch in the “OFF” position.
- b. Disconnect wire leads to coil.
- c. Remove coil retaining screw and nameplate.
- d. Lift burned-out coil from enclosing coil assembly and replace.
- e. Connect wire leads and test operation.



4.21.3 Replacing the Internal Valve Parts



Be careful of remaining hot coolant in the hoses when disassembling.

- a. Drain the heater coil.
- b. Disassemble valve and replace defective parts.
- c. Assemble valve and connect coolant hoses.

4.21.4 Replacing the Valve Assembly

- a.. Drain the heater coil.
- b. Disconnect wire leads to the solenoid coil.
- c.. Disconnect the hoses from both sides of the valve assembly.
- d.. Remove the hex nut and washer securing the valve assembly to the valve bracket.
- e.. Remove the valve bracket assembly from the panel.
- f.. Remove valve assembly from the unit.
- g.. Install new valve and re-connect hoses. It is not necessary to disassemble the valve when installing.
- h.. Fill the system with coolant.
- i.. Connect wire leads and test operation.



4.22 LOGIC BOARD REPLACEMENT

Control configuration is preset at the factory and resetting of the parameters is not advised. If a replacement Logic Board is installed, it is necessary to match the configuration jumpers (see Figure 1-6) to the original board. Table 4-3 provides a list of jumper functions. MCC is not responsible for failures or damage resulting from unauthorized changes.

Table 4-3. Logic Board Configuration

Configuration	Description
A.	High Reheat - When this configuration is removed, the unit will default to high speed in reheat mode and in the low speed cool band. If not removed, heat/reheat will default to low speed.
B.	High Vent - When this configuration is removed, the unit will default to high speed in vent mode. If not removed vent mode will default to low speed.
C.	Dry Heat - When this configuration is removed, the unit will run on 100% reheat instead of heat.
D.	Reheat/Cycle - When the reheat cycle configuration is removed, the unit is in reheat mode. The default configuration is cycle clutch mode.
E.	Transducers - When the transducer configuration is removed, transducers will assume to be present.
F.	Refrigerant R-22/R-134a - When the refrigerant configuration is removed, the refrigerant is set for R-22. The default refrigerant is R-134a.
G.	Unit Type - Rearmount unit enabled with "G" removed and "H" installed.
H.	Unit Type - With "H" removed and "G" installed, roof top unit will be enabled.
I.	Factory - Reserved for the manufacturer.
J.	Invert H ₂ O - When this configuration is removed, the logic for the water temperature switch will be inverted.
K.	Voltage - When this configuration is removed, the voltage selection will be changed from 12 to 24 vdc.
L.	Factory - Reserved for the manufacturer.
M.	Psig/Bars - When this configuration is removed, the display will indicate pressures in <i>bars</i> . When not removed, the display will indicate pressures in <i>psig</i> .
N.	°C/°F - When this configuration is removed, the display will show temperatures in °F. When not removed the display will show temperatures in °C.
O.	PI Reheat - When this configuration is removed, reheat mode will use the PI algorithm to vary the duty cycle of the heat valve. If it is not removed, the heat valve will be on constantly.
P.	Low Ambient Lockout - When this configuration is removed, the compressor clutch will disengage at 25°F. With this configuration in place, the compressor will disengage at 45°F.



Table 4-4. R-134a Temperature - Pressure Chart

Temperature		Vacuum		
°F	°C	"/hg	Kg/cm ²	Bar
-40	-40	14.6	37.08	0.49
-35	-37	12.3	31.25	0.42
-30	-34	9.7	24.64	0.33
-25	-32	6.7	17.00	0.23
-20	-29	3.5	8.89	0.12
-18	-28	2.1	5.33	0.07
-16	-27	0.6	1.52	0.02

Temperature		Pressure		
°F	°C	Psig	Kg/cm ²	Bar
-14	-26	0.4	0.03	0.03
-12	-24	1.2	0.08	0.08
-10	-23	2.0	0.14	0.14
-8	-22	2.9	0.20	0.20
-6	-21	3.7	0.26	0.26
-4	-20	4.6	0.32	0.32
-2	-19	5.6	0.39	0.39
0	-18	6.5	0.46	0.45
2	-17	7.6	0.53	0.52
4	-16	8.6	0.60	0.59
6	-14	9.7	0.68	0.67
8	-13	10.8	0.76	0.74
10	-12	12.0	0.84	0.83
12	-11	13.2	0.93	0.91
14	-10	14.5	1.02	1.00
16	-9	15.8	1.11	1.09
18	-8	17.1	1.20	1.18
20	-7	18.5	1.30	1.28
22	-6	19.9	1.40	1.37
24	-4	21.4	1.50	1.48
26	-3	22.9	1.61	1.58

Temperature		Pressure		
°F	°C	Psig	Kg/cm ²	Bar
28	-2	24.5	1.72	1.69
30	-1	26.1	1.84	1.80
32	0	27.8	1.95	1.92
34	1	29.6	2.08	2.04
36	2	31.3	2.20	2.16
38	3	33.2	2.33	2.29
40	4	35.1	2.47	2.42
45	7	40.1	2.82	2.76
50	10	45.5	3.20	3.14
55	13	51.2	3.60	3.53
60	16	57.4	4.04	3.96
65	18	64.1	4.51	4.42
70	21	71.1	5.00	4.90
75	24	78.7	5.53	5.43
80	27	86.7	6.10	5.98
85	29	95.3	6.70	6.57
90	32	104.3	7.33	7.19
95	35	114.0	8.01	7.86
100	38	124.2	8.73	8.56
105	41	135.0	9.49	9.31
110	43	146.4	10.29	10.09
115	46	158.4	11.14	10.92
120	49	171.2	12.04	11.80
125	52	184.6	12.98	12.73
130	54	198.7	13.97	13.70
135	57	213.6	15.02	14.73
140	60	229.2	16.11	15.80
145	63	245.6	17.27	16.93
150	66	262.9	18.48	18.13
155	68	281.1	19.76	19.37



SECTION 5

ELECTRICAL

5-1 INTRODUCTION

This section includes electrical wiring schematics covering the models listed in Table 1-1. For applications with OEM supplied operating switches, the switches are wired to the Logic Board connector J3 as shown. For units with a Micromate as the operators control, there is no wiring to the Logic Board J3 connector, instead the Micromate is hard wired to the Logic Board connector J2. When the micromate is used for service or diagnostic purposes, it is wired in the same manner as shown for drivers panel use, thru the optional Service Port. Contact your Mobile Climate Control service representative or call the technical hot line at 800-450-2211 for questions related to the schematic for your specific model.



SYMBOLS

	INDICATES CONNECTOR TERMINAL
	INDICATES GROUND
	INDICATES CIRCUIT ON BOARD
	INDICATES A WIRE
	INDICATES A WIRE (DEM SUPPLIED)
	INDICATES POWER STUD
	INDICATES A NORMALLY CLOSED CONTACT
	INDICATES A NORMALLY OPEN CONTACT
	INDICATES A BUS INTERFACE CONNECTOR, POSITION 'A'
	INDICATES A CONNECTOR, POSITION 'A'
	INDICATES LAMP
	INDICATES DIODE
	INDICATES FUSE
	INDICATES A COIL
	INDICATES MOTOR
	INDICATES PRESSURE TRANSDUCER
	INDICATES LED ASSEMBLY
	INDICATES PRESSURE SWITCH NC
	INDICATES TEMPERATURE SENSOR
	INDICATES MANUAL RESET BREAKER
	INDICATES RELAY COIL
	INDICATES SWITCH N/O
	INDICATES POLY SWITCH
	INDICATES TEMPERATURE SWITCH NO
	INDICATES MULTI-PLEX MODULE
	INDICATES RIBBON CABLE
	INDICATES RESISTOR

LEGEND

SHEET NO. /ZONE	SYMBOL	DESCRIPTION
3, 4, 5/D-2	A/C FAIL	A/C FAIL
2/B-6	ATS	AMBIENT TEMPERATURE SENSOR
3, 4, 5/D-1	BPS	BOOST PUMP SIGNAL
2/C-5	CAN L	CONTROLLER AREA NETWORK LOW
2/C-5	CAN H	CONTROLLER AREA NETWORK HIGH
3, 4, 5/C-1	CB1	CIRCUIT BREAKER, 15A
3, 4/B-8, 5/C-8	CB2	CIRCUIT BREAKER, SEE DIAGRAM
3, 4/B-7, 5/C-8	CB3	CIRCUIT BREAKER, SEE DIAGRAM
3, 4/B-6, 5/C-7	CB4	CIRCUIT BREAKER, SEE DIAGRAM
3, 4/B-7, 5/C-7	CB5	CIRCUIT BREAKER, SEE DIAGRAM
3, 4/D-6, B-7, 5-B-7	CFR1	COND FAN RELAY 1
3, 4/D-5, B-7	CFR2	COND FAN RELAY 2
3, 4, 5/C-7	CM1	COND MOTOR 1
3, 4, 5/C-6	CM2	COND MOTOR 2
5/D-6	CMC1	COND MOTOR CONTROL 1
5/D-6	CMC2	COND MOTOR CONTROL 2
3, 4, 5/C-3	CL	COMPRESSOR CLUTCH
3, 4, 5/D-6, D-7	CSR	CONDENSER SPEED RELAY
2/D-7		LED
2/B-6	DPT	DISCHARGE PRESSURE TRANSDUCER
3, 4, 5/C-8	EM1	EVAP MOTOR 1
3, 4, 5/D-8	EM2	EVAP MOTOR 2
5/C-5	EMC1	EVAP MOTOR CONTROL 1
5/C-5	EMC2	EVAP MOTOR CONTROL 2
3, 4/D-5, B-7, 5/B-7	EFR1	EVAPORATOR FAN RELAY 1
3, 4/B-8, D-4	EFR2	EVAPORATOR FAN RELAY 2
3, 4/D-5, C-7, 5/C-5	ESR	EVAPORATOR SPEED RELAY
3, 4, 5/D-4	FBM	FLOOR BLOWER MOTOR SIGNAL
2/C-6	DEM FUSE	DEM FUSE (3 AMP)
2/D-6, 3, 4, 5/B-1	F1	FUSE <10 AMP>
2/D-5	F2	FUSE <10 AMP>
3, 4, 5/A-6	F7	FUSE, 15A
3, 4, 5/A-5	F13	FUSE, 15A
3, 4, 5/A-6	F14	FUSE <20 AMP>
3, 4, 5/C-3	HPS	HIGH PRESSURE SWITCH
2/B-3, 3, 4, 5/B-5	K1	EF1/2 RELAY
2/B-3, 3, 4, 5/B-5	K2	EVAP HIGH SPEED RELAY
2/B-3, 3, 4, 5/B-6	K7	CF1/2 RELAY
2/B-2, 3, 4, 5/B-6	K8	COND HIGH SPEED RELAY
2/C-4, 3, 4, 5/B-3	K13	CLUTCH RELAY
2/C-4, 3, 4, 5/B-3	K14	UV1 RELAY
2/C-3, 3, 4, 5/B-4	K15	UV2 RELAY (NOT USED)
2/C-4	K16	FRESH AIR RELAY
2/C-3, 3, 4, 5/B-3	K17	HEAT RELAY
2/C-4, 3, 4, 5/B-2	K18	FAULT RELAY
2/B-3, 3, 4, 5/B-1	K19	BOOST PUMP RELAY
2, 3, 4, 5/B-4	K20	FLOOR BLOWER RELAY
2/C-5	LPS	LOW PRESSURE SWITCH
3, 4, 5/C-3	LSV1	LIQUID LINE SOLENOID<INSIDE RM UNIT>
3, 4, 5/C-3	LSV2	LIQUID LINE SOLENOID<INSIDE OPTIONAL ESS COOLER>
2/C-5, D-5	PR	POWER RELAY
2/D-3	R23	RESISTOR
2/B-6	RAS	RETURN AIR SENSOR
3, 4, 5/C-2	RCV	REHEAT COOLANT VALVE
2/B-6	SPT	SUCTION PRESSURE TRANSDUCER
3, 4, 5/C-4	UV1	UNLOADER SOLENOID VALVE #1
3, 4, 5/C-3	UV2	UNLOADER SOLENOID VALVE #2

LOGIC BOARD JUMPER CONFIGURATION

JUMPER	REMOVED	INSTALLED
A		X
B	X	
C		X
D	X	
E	X	
F		X
G	X	
H		X
I	X	
J	X	
K	X	
L	X	
M		X
N	X	
O	X	
P		X

CONNECTOR LEGEND

SHEET NO. /ZONE	SYMBOL	DESCRIPTION
2/B-5, 2/D-5	J1	LOGIC POWER CONNECTOR
2/D-5	J2	DISPLAY INTERFACE
2/D-5	J3	ON/TEST CONNECTOR
2/C-5	J4	INPUT CONNECTOR
2/D-4	J5	RELAY BOARD INTERFACE CONNECTOR
2/B-5	J6	SENSOR CONNECTOR
NOT SHOWN	J7	DIAGNOSTIC INTERFACE<ON LOGIC BOARD>
2/A-5 - D-5	JP2	LOGIC BOARD INTERFACE CONNECTOR
3, 4, 5/B-1, B-2	JP3	BOOST PUMP CONNECTOR
3, 4, 5/B-2, B-4	JP4	CLUTCH/FAIL CONNECTOR
3, 4, 5/B-3	JP5	HEAT CONNECTOR
3, 4, 5/C-3, C-4	JP6	UNLOADER CONNECTOR
3, 4, 5/B-7	JP7	EVAPORATOR FAN / SPEED
3, 4, 5/A-5	JP8	24 VOLT POWER
3, 4, 5/B-5, B-6	JP9	CONDENSER FAN / SPEED

98-03319 A

Figure 5-1. Wiring Schematic - Legend - 68RM35-610 (All)

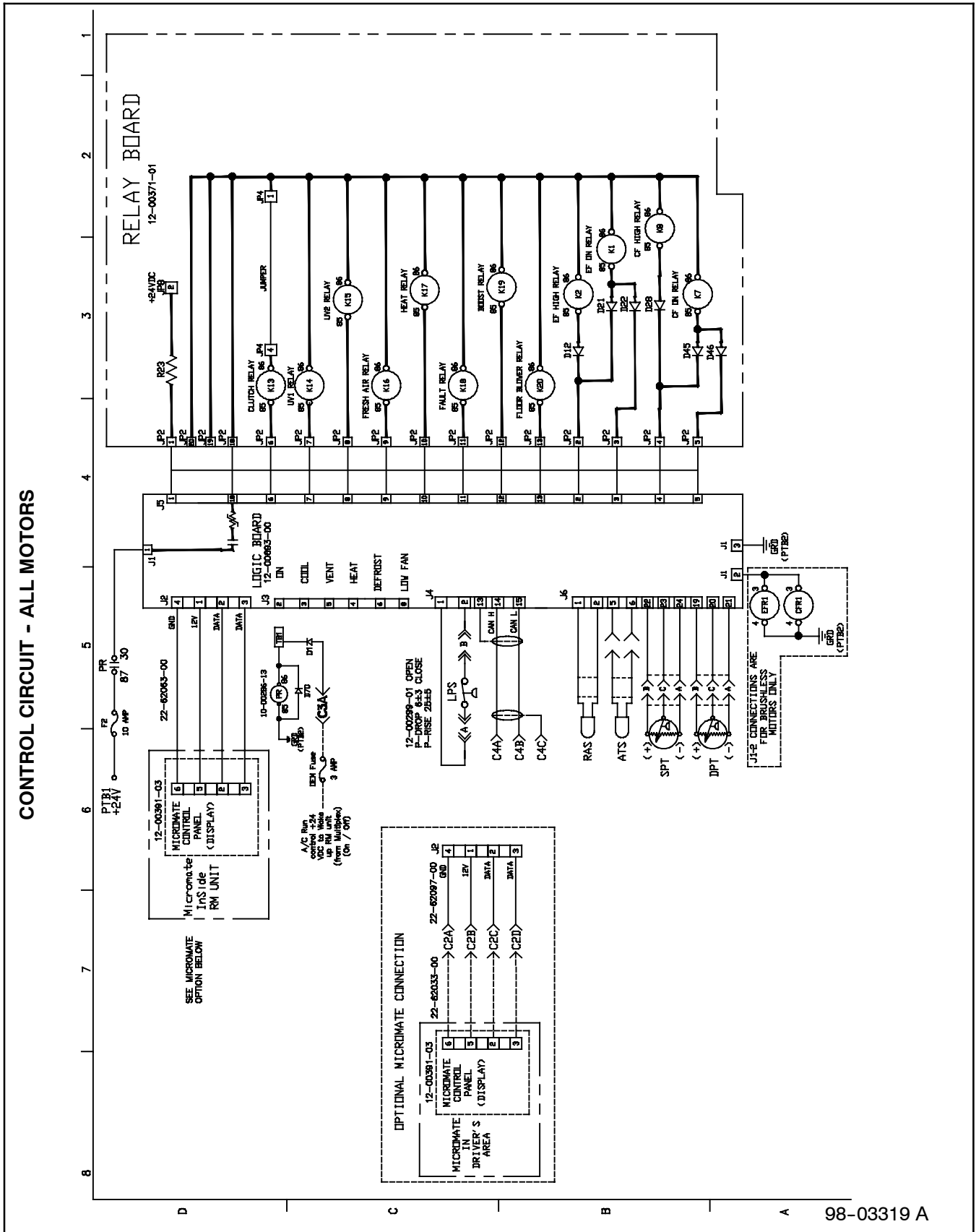
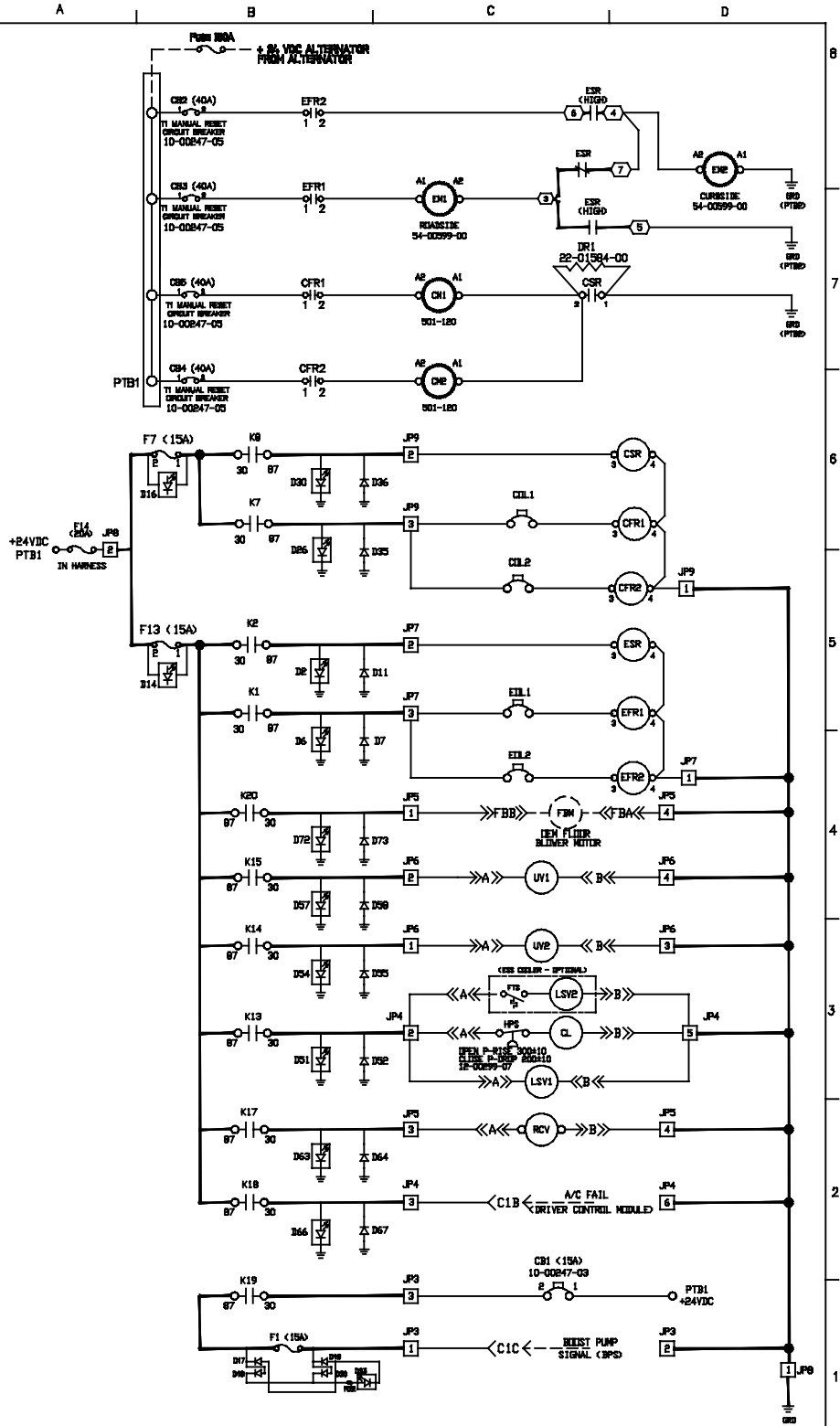

Figure 5-2. Wiring Schematic - Control Circuit - 68RM35-610- 1 thru 9



POWER CIRCUIT - PERMANENT MAGNET MOTORS



98-03319 A

Figure 5-3. Wiring Schematic - Power Circuit - 68RM35-610-3, -4, -5

POWER CIRCUIT - WOUND FIELD MOTORS

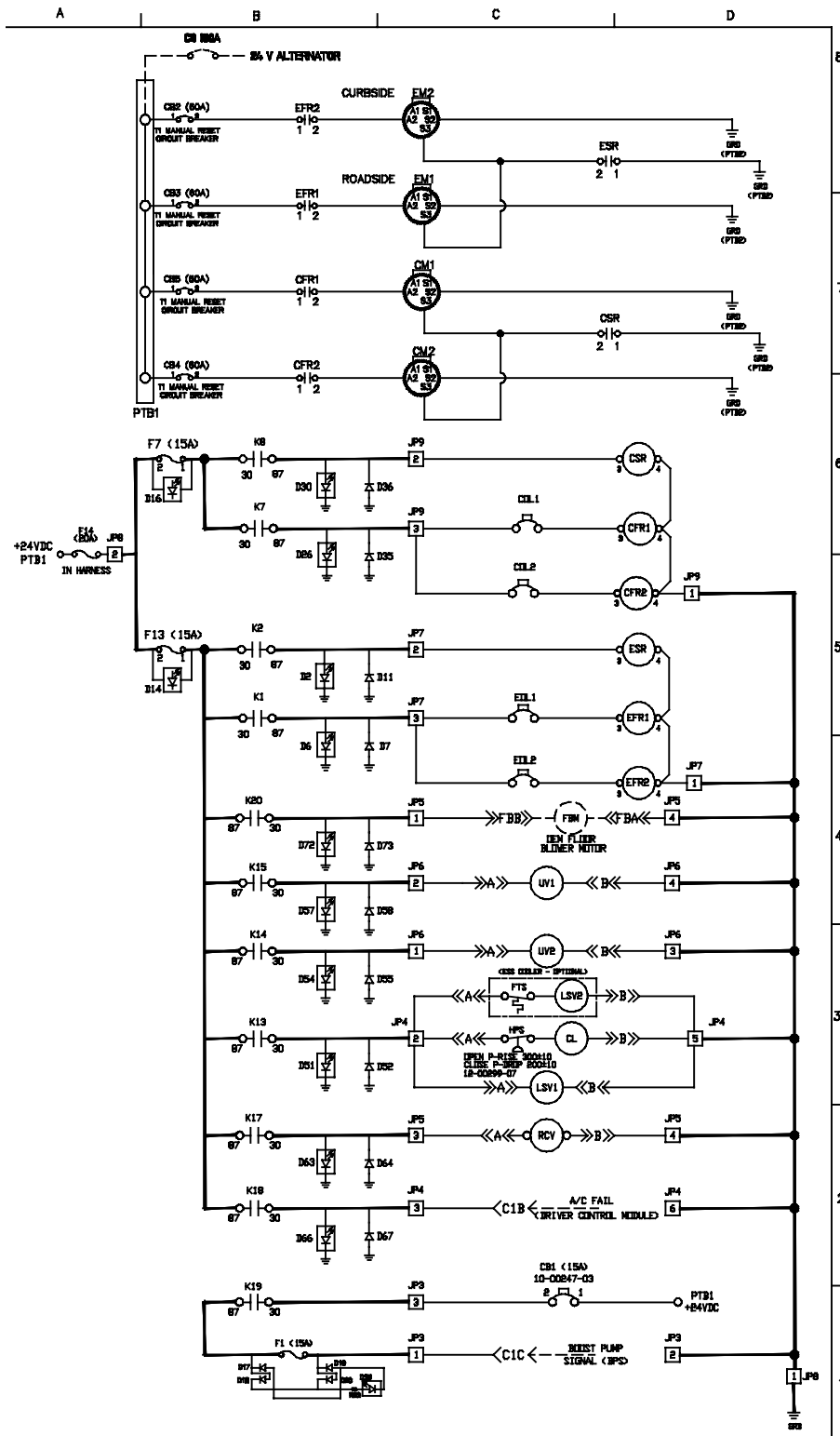

98-03319 A

Figure 5-4. Wiring Schematic - Power Circuit - 68RM35-610-1, -2

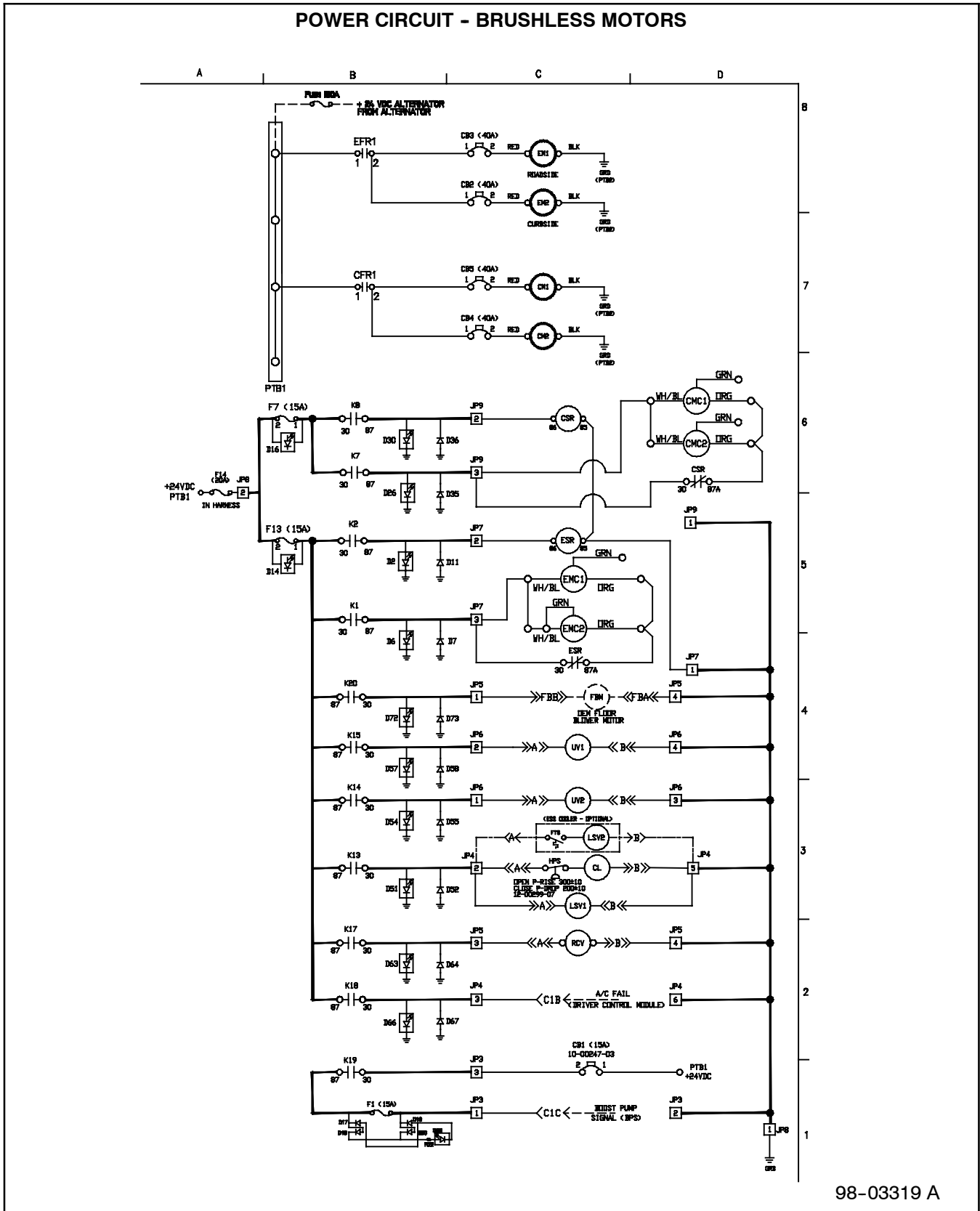
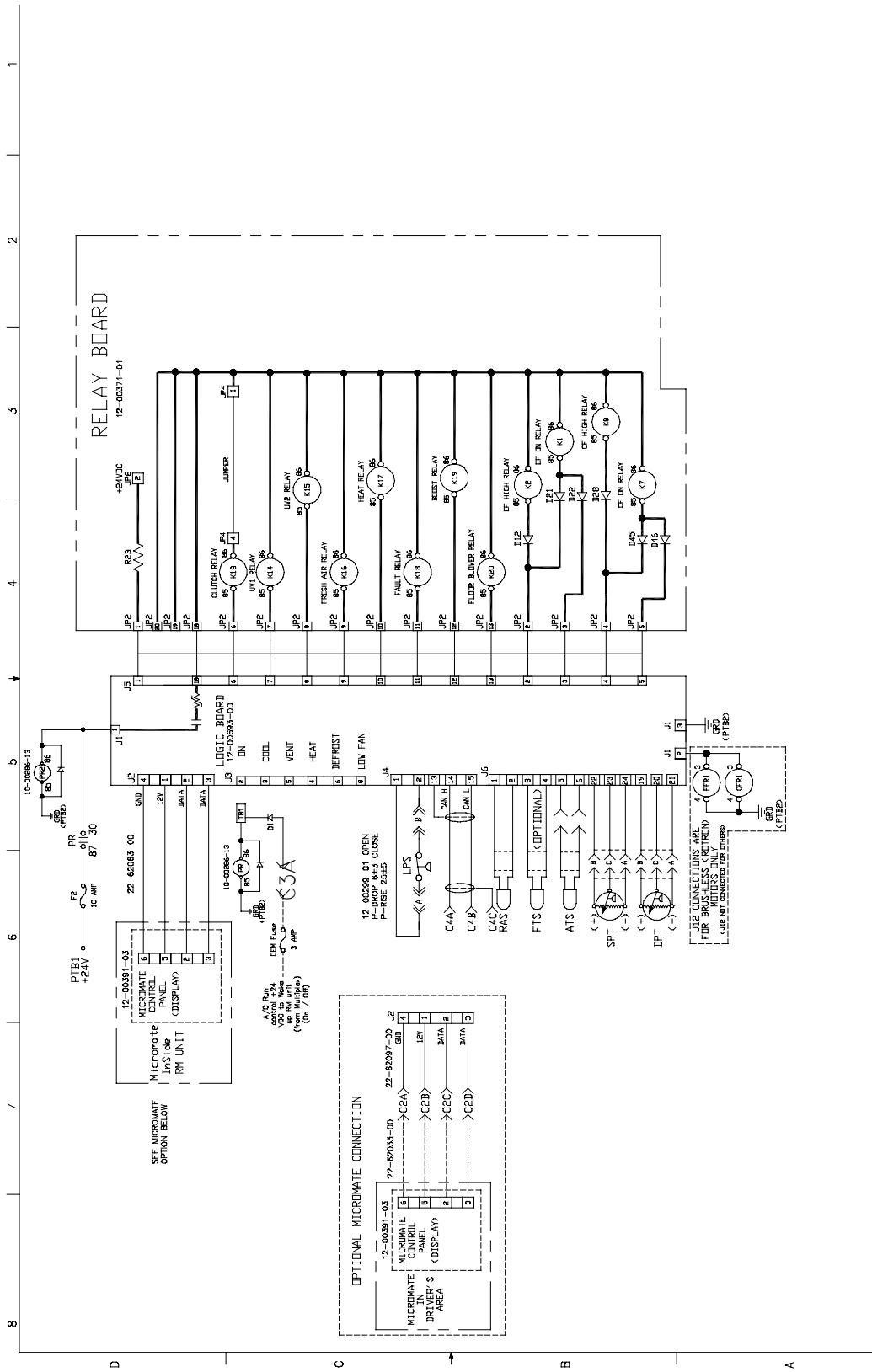

Figure 5-5. Wiring Schematic - Power Circuit - 68RM35-610, 6, -7, -8, -9



CONTROL CIRCUIT



Y66-00021

Figure 5-6. Wiring Schematic - Control Circuit - 68RM35-610-10

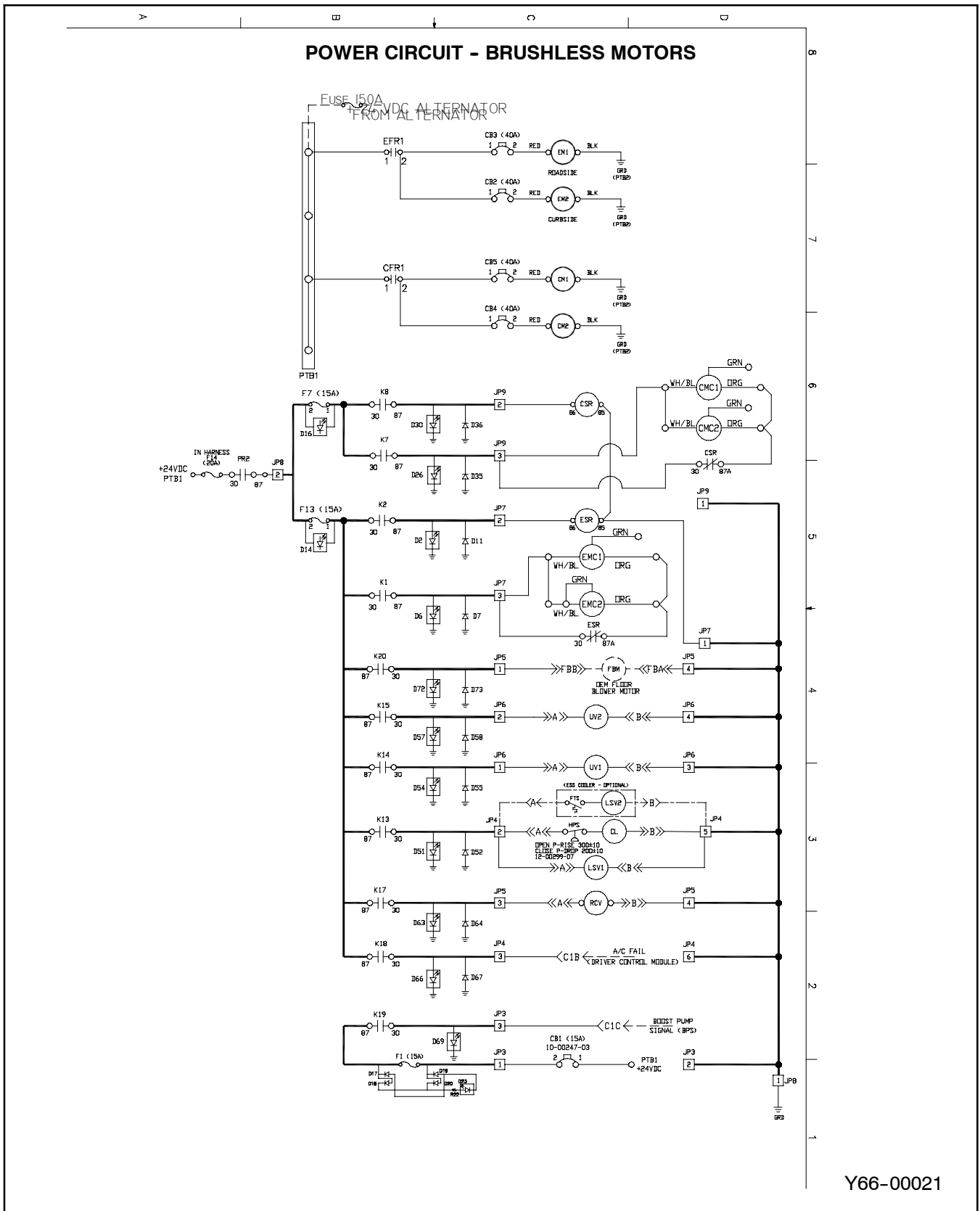

Figure 5-7. Wiring Schematic - Power Circuit - 68RM35-610-10



SYMBOLS

	INDICATES CONNECTOR TERMINAL
	INDICATES GROUND
	INDICATES CIRCUIT ON BOARD
	INDICATES A WIRE
	INDICATES A WIRE (DEM SUPPLIED)
	INDICATES POWER STUD
	INDICATES A NORMALLY CLOSED CONTACT
	INDICATES A NORMALLY OPEN CONTACT
	INDICATES A BUS INTERFACE CONNECTOR, POSITION 'A'
	INDICATES A CONNECTOR, POSITION 'A'
	INDICATES LAMP
	INDICATES DIODE
	INDICATES FUSE
	INDICATES A COIL
	INDICATES MOTOR
	INDICATES PRESSURE TRANSDUCER
	INDICATES LED ASSEMBLY
	INDICATES PRESSURE SWITCH NC
	INDICATES TEMPERATURE SENSOR
	INDICATES MANUAL RESET BREAKER
	INDICATES RELAY COIL
	INDICATES SWITCH N/O
	INDICATES POLY SWITCH
	INDICATES TEMPERATURE SWITCH NO
	INDICATES MULTI-PLEX MODULE
	INDICATES RIBBON CABLE
	INDICATES RESISTOR

LOGIC BOARD JUMPER CONFIGURATION

JUMPER	REMOVED	INSTALLED
A		X
B	X	
C		X
D	X	
E	X	
F		X
G	X	
H		X
I	X	
J	X	
K	X	
L	X	
M		X
N	X	
O	X	
P		X

LEGEND

SHEET NO. /ZONE	SYMBOL	DESCRIPTION
3/D-2	A/C FAIL	A/C FAIL
2/B-6	ATS	AMBIENT TEMPERATURE SENSOR
3/D-2	BPS	BOOST PUMP SIGNAL
2/C-5	CAN L	CONTROLLER AREA NETWORK LOW
2/C-5	CAN H	CONTROLLER AREA NETWORK HIGH
3/C-1	CB1	CIRCUIT BREAKER, 15A
3/C-8	CB2	CIRCUIT BREAKER, SEE DIAGRAM
3/C-8	CB3	CIRCUIT BREAKER, SEE DIAGRAM
3/C-7	CB4	CIRCUIT BREAKER, SEE DIAGRAM
3/C-7	CB5	CIRCUIT BREAKER, SEE DIAGRAM
3/C-7	CB6	CIRCUIT BREAKER, SEE DIAGRAM
3/B-7	CFR1	COND FAN RELAY 1
3/C-7	CM1	COND MOTOR 1
3/C-7	CM2	COND MOTOR 2
3/C-6	CM3	COND MOTOR 3
3/D-7	CMC1	COND MOTOR CONTROL 1
3/D-6	CMC2	COND MOTOR CONTROL 2
3/D-6	CMC3	COND MOTOR CONTROL 3
3/C-3	CL	COMPRESSOR CLUTCH
3/C-6	CSR	CONDENSER SPEED RELAY
2/B-6	DPT	DISCHARGE PRESSURE TRANSDUCER
3/C-8	EM1	EVAP MOTOR 1
3/C-8	EM2	EVAP MOTOR 2
3/C-5	EMC1	EVAP MOTOR CONTROL 1
3/C-5	EMC2	EVAP MOTOR CONTROL 2
3/B-8	EFR1	EVAPORATOR FAN RELAY 1
3/C-5	ESR	EVAPORATOR SPEED RELAY
3/D-4	FBM	FLOOR BLOWER MOTOR SIGNAL
2/C-6	DEM FUSE	DEM FUSE (3 AMP)
3/B-1	F1	FUSE (10 AMP)
2/D-6	F2	FUSE (10 AMP)
3/B-6	F7	FUSE, 15A
3/B-5	F13	FUSE, 15A
3/A-6	F14	FUSE (20 AMP)
3/C-3	HPS	HIGH PRESSURE SWITCH
2/B-3, 3/B-5	K1	EF1/2 RELAY
2/B-3, 3/B-5	K2	EVAP HIGH SPEED RELAY
2/B-3, 3/B-6	K7	CF1/2 RELAY
2/B-3, 3/B-6	K8	COND HIGH SPEED RELAY
2/C-4, 3/B-3	K13	CLUTCH RELAY
2/C-4, 3/B-3	K14	UV1 RELAY
2/C-3, 3/B-4	K15	UV2 RELAY (NOT USED)
2/C-4	K16	FRESH AIR RELAY
2/C-3, 3/B-3	K17	HEAT RELAY
2/C-4, 3/B-2	K18	FAULT RELAY
2/B-3, 3/B-1	K19	BOOST PUMP RELAY
2, 3/B-4	K20	FLOOR BLOWER RELAY
2/C-5	LPS	LOW PRESSURE SWITCH
3/C-3	LSV1	LIQUID LINE SOLENOID (INSIDE RM UNIT)
3/C-3	LSV2	LIQUID LINE SOLENOID (INSIDE OPTIONAL ESS COOLER)
2/C-5, D-5	PR	POWER RELAY
2/D-5 3/A-6	PR2	POWER RELAY
2/D-3	R23	RESISTOR
2/B-6	RAS	RETURN AIR SENSOR
3/C-3	RCV	REHEAT COOLANT VALVE
2/B-6	SPT	SUCTION PRESSURE TRANSDUCER
3/C-3	UV1	UNLOADER SOLENOID VALVE #1
3/C-4	UV2	UNLOADER SOLENOID VALVE #2
3/D-6	SPLICE 1	WIRE SPLICE #1

CONNECTOR LEGEND

SHEET NO. /ZONE	SYMBOL	DESCRIPTION
2/B-5, 2/D-5	J1	LOGIC POWER CONNECTOR
2/D-5	J2	DISPLAY INTERFACE
2/D-5	J3	DN/TEST CONNECTOR
2/C-5	J4	INPUT CONNECTOR
2/D-4	J5	RELAY BOARD INTERFACE CONNECTOR
2/B-5	J6	SENSOR CONNECTOR
NOT SHOWN	J7	DIAGNOSTIC INTERFACE (ON LOGIC BOARD)
2/A-5 - D-5	JP2	LOGIC BOARD INTERFACE CONNECTOR
3/B-1, B-2	JP3	BOOST PUMP CONNECTOR
3/B-2, B-4	JP4	CLUTCH/FAIL CONNECTOR
3/B-3	JP5	HEAT CONNECTOR
3/C-3, C-4	JP6	UNLOADER CONNECTOR
3/B-7	JP7	EVAPORATOR FAN / SPEED
3/A-5	JP8	24 VOLT POWER
3/B-5, B-6	JP9	CONDENSER FAN / SPEED

Y66-00040

Figure 5-8. Wiring Schematic - Legend - Y13-R3501-00 & -02



CONTROL CIRCUIT

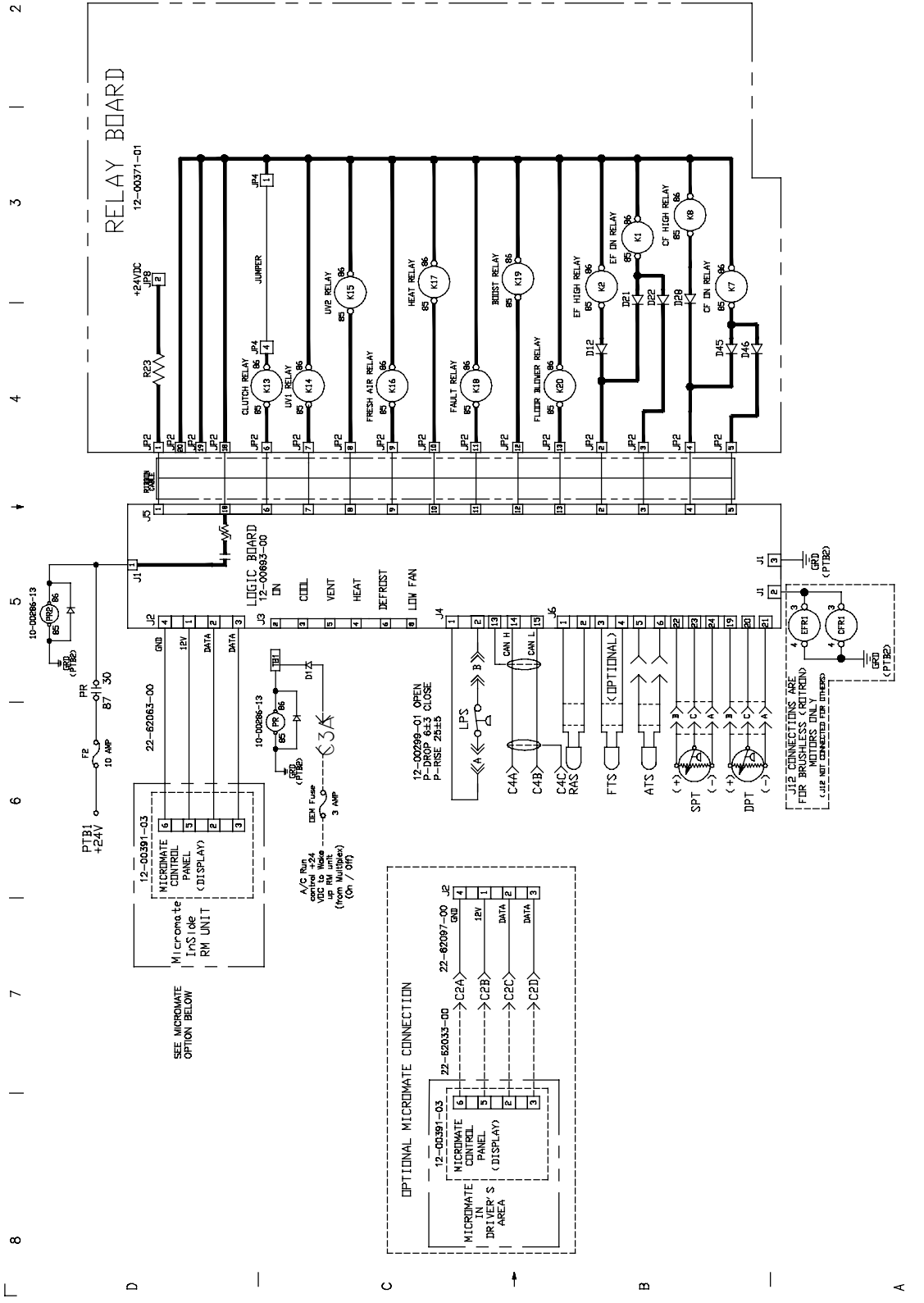

Y66-00040

Figure 5-9. Wiring Schematic - Control Circuit - Y13-R3501-00 & -02

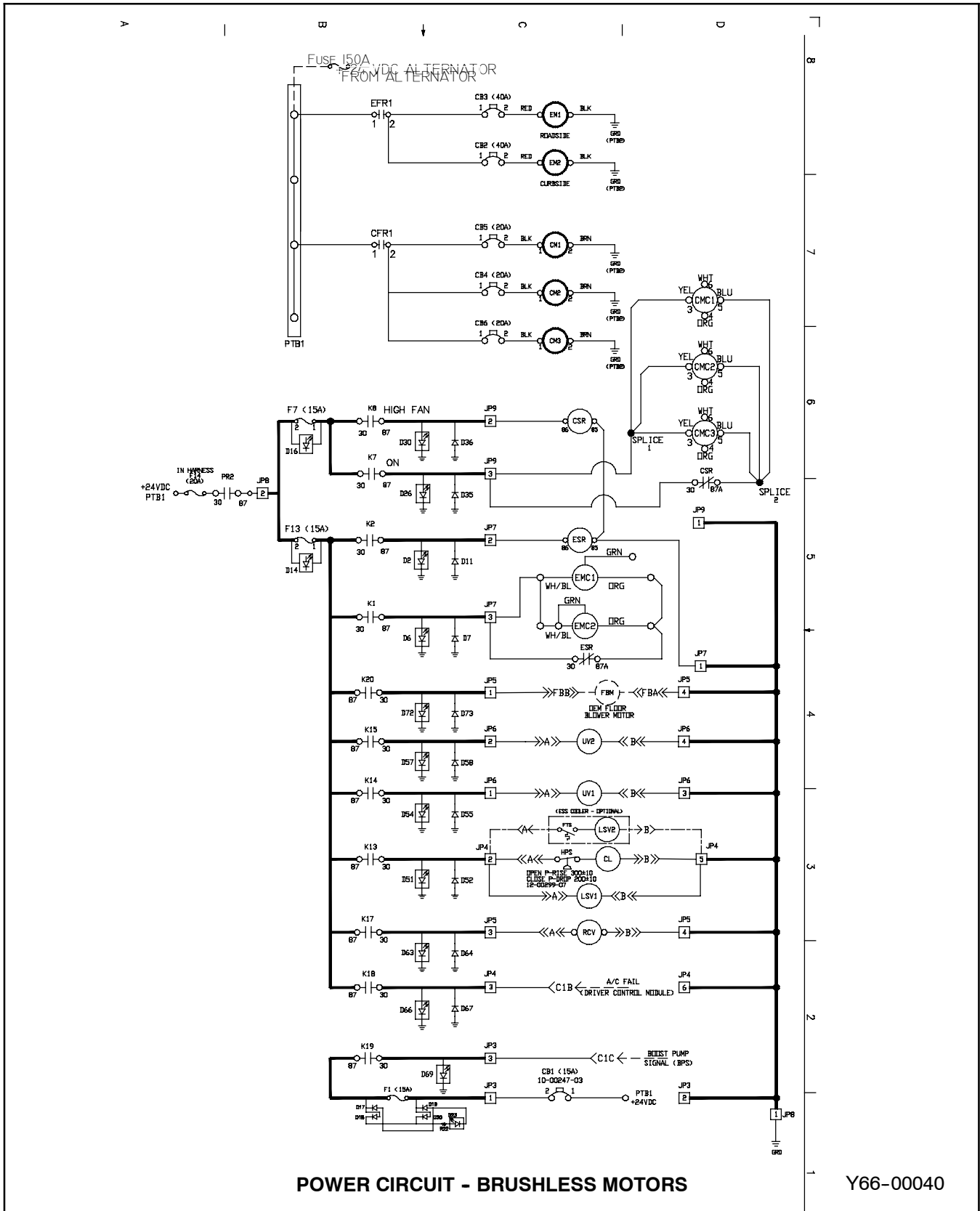

Figure 5-10. Wiring Schematic - Power Circuit - Y13-R3501-00 & -02



SYMBOLS

	INDICATES CONNECTOR TERMINAL
	INDICATES GROUND
	INDICATES CIRCUIT ON BOARD
	INDICATES A WIRE
	INDICATES A WIRE (DEM SUPPLIED)
	INDICATES POWER STUD
	INDICATES A NORMALLY CLOSED CONTACT
	INDICATES A NORMALLY OPEN CONTACT
	INDICATES A BUS INTERFACE CONNECTOR, POSITION 'A'
	INDICATES A CONNECTOR, POSITION 'A'
	INDICATES LAMP
	INDICATES DIODE
	INDICATES FUSE
	INDICATES A COIL
	INDICATES MOTOR
	INDICATES PRESSURE TRANSDUCER
	INDICATES LED ASSEMBLY
	INDICATES PRESSURE SWITCH NC
	INDICATES TEMPERATURE SENSOR
	INDICATES MANUAL RESET BREAKER
	INDICATES RELAY COIL
	INDICATES SWITCH N/O
	INDICATES POLY SWITCH
	INDICATES TEMPERATURE SWITCH NO
	INDICATES MULTI-PLEX MODULE
	INDICATES RIBBON CABLE
	INDICATES RESISTOR

LOGIC BOARD JUMPER CONFIGURATION

JUMPER	REMOVED	INSTALLED
A		X
B	X	
C		X
D	X	
E	X	
F		X
G	X	
H		X
I	X	
J	X	
K	X	
L	X	
M		X
N	X	
O	X	
P		X

LEGEND

SHEET NO. /ZONE	SYMBOL	DESCRIPTION
3/D-2	A/C FAIL	A/C FAIL
2/B-6	ATS	AMBIENT TEMPERATURE SENSOR
3/D-2	BPS	BOOST PUMP SIGNAL
2/C-5	CAN L	CONTROLLER AREA NETWORK LOW
2/C-5	CAN H	CONTROLLER AREA NETWORK HIGH
3/C-1	CB1	CIRCUIT BREAKER, 15A
3/C-8	CB2	CIRCUIT BREAKER, SEE DIAGRAM
3/C-8	CB3	CIRCUIT BREAKER, SEE DIAGRAM
3/C-7	CB4	CIRCUIT BREAKER, SEE DIAGRAM
3/C-7	CB5	CIRCUIT BREAKER, SEE DIAGRAM
3/C-7	CB6	CIRCUIT BREAKER, SEE DIAGRAM
3/B-7	CFR1	COND FAN RELAY 1
3/C-7	CM1	COND MOTOR 1
3/C-7	CM2	COND MOTOR 2
3/C-6	CM3	COND MOTOR 3
3/D-7	CMC1	COND MOTOR CONTROL 1
3/D-6	CMC2	COND MOTOR CONTROL 2
3/D-6	CMC3	COND MOTOR CONTROL 3
3/C-3	CL	COMPRESSOR CLUTCH
3/C-6	CSR	CONDENSER SPEED RELAY
2/B-6	DPT	DISCHARGE PRESSURE TRANSDUCER
3/C-8	EM1	EVAP MOTOR 1
3/C-8	EM2	EVAP MOTOR 2
3/C-5	EMC1	EVAP MOTOR CONTROL 1
3/C-5	EMC2	EVAP MOTOR CONTROL 2
3/B-8	EFR1	EVAPORATOR FAN RELAY 1
3/C-5	ESR	EVAPORATOR SPEED RELAY
3/D-4	FBM	FLOOR BLOWER MOTOR SIGNAL
2/C-6	DEM FUSE	DEM FUSE (3 AMP)
3/B-1	F1	FUSE (10 AMP)
2/D-6	F2	FUSE (10 AMP)
3/B-6	F7	FUSE, 15A
3/B-5	F13	FUSE, 15A
3/A-6	F14	FUSE (20 AMP)
3/C-3	HPS	HIGH PRESSURE SWITCH
2/B-3, 3/B-5	K1	EF1/2 RELAY
2/B-3, 3/B-5	K2	EVAP HIGH SPEED RELAY
2/B-3, 3/B-6	K7	CF1/2 RELAY
2/B-3, 3/B-6	K8	COND HIGH SPEED RELAY
2/C-4, 3/B-3	K13	CLUTCH RELAY
2/C-4, 3/B-3	K14	UV1 RELAY
2/C-3, 3/B-4	K15	UV2 RELAY (NOT USED)
2/C-4	K16	FRESH AIR RELAY
2/C-3, 3/B-3	K17	HEAT RELAY
2/C-4, 3/B-2	K18	FAULT RELAY
2/B-3, 3/B-1	K19	BOOST PUMP RELAY
2, 3/B-4	K20	FLOOR BLOWER RELAY
2/C-5	LPS	LOW PRESSURE SWITCH
3/C-3	LSV1	LIQUID LINE SOLENOID (INSIDE RM UNIT)
3/C-3	LSV2	LIQUID LINE SOLENOID (INSIDE OPTIONAL ESS COOLER)
2/C-5, D-5	PR	POWER RELAY
2/D-5 3/A-6	PR2	POWER RELAY
2/D-3	R23	RESISTOR
2/B-6	RAS	RETURN AIR SENSOR
3/C-3	RCV	REHEAT COOLANT VALVE
2/B-6	SPT	SUCTION PRESSURE TRANSDUCER
3/C-3	UV1	UNLOADER SOLENOID VALVE #1
3/C-4	UV2	UNLOADER SOLENOID VALVE #2
3/D-6	SPLICE 1	WIRE SPLICE #1

CONNECTOR LEGEND

SHEET NO. /ZONE	SYMBOL	DESCRIPTION
2/B-5, 2/D-5	J1	LOGIC POWER CONNECTOR
2/D-5	J2	DISPLAY INTERFACE
2/D-5	J3	DN/TEST CONNECTOR
2/C-5	J4	INPUT CONNECTOR
2/D-4	J5	RELAY BOARD INTERFACE CONNECTOR
2/B-5	J6	SENSOR CONNECTOR
NOT SHOWN	J7	DIAGNOSTIC INTERFACE (ON LOGIC BOARD)
2/A-5 - D-5	JP2	LOGIC BOARD INTERFACE CONNECTOR
3/B-1, B-2	JP3	BOOST PUMP CONNECTOR
3/B-2, B-4	JP4	CLUTCH/FAIL CONNECTOR
3/B-3	JP5	HEAT CONNECTOR
3/C-3, C-4	JP6	UNLOADER CONNECTOR
3/B-7	JP7	EVAPORATOR FAN / SPEED
3/A-5	JP8	24 VOLT POWER
3/B-5, B-6	JP9	CONDENSER FAN / SPEED

Y66-00054

Figure 5-11. Wiring Schematic - Legend - Y13-R3501-01

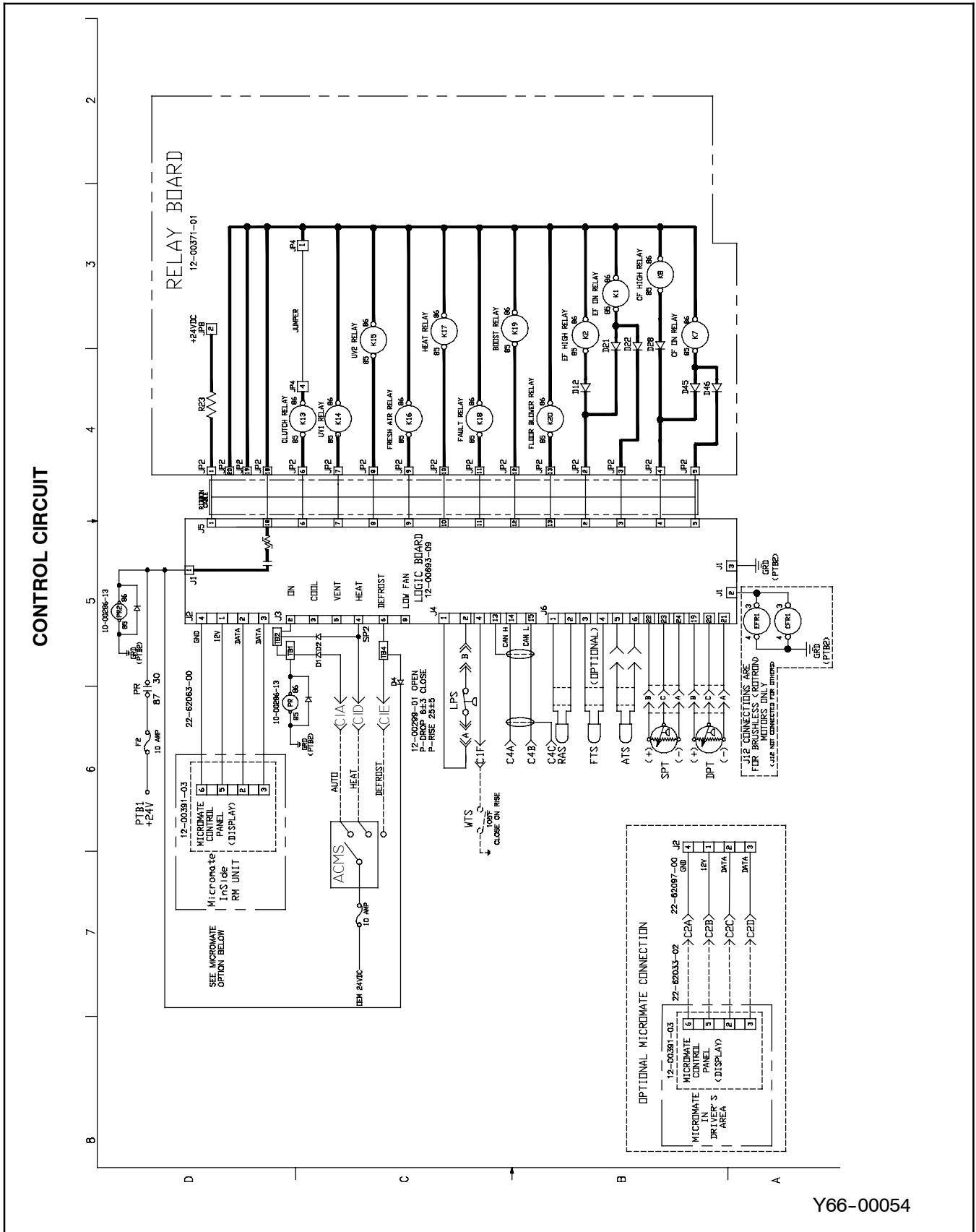

Y66-00054

Figure 5-12. Wiring Schematic - Control Circuit - Y13-R3501-01

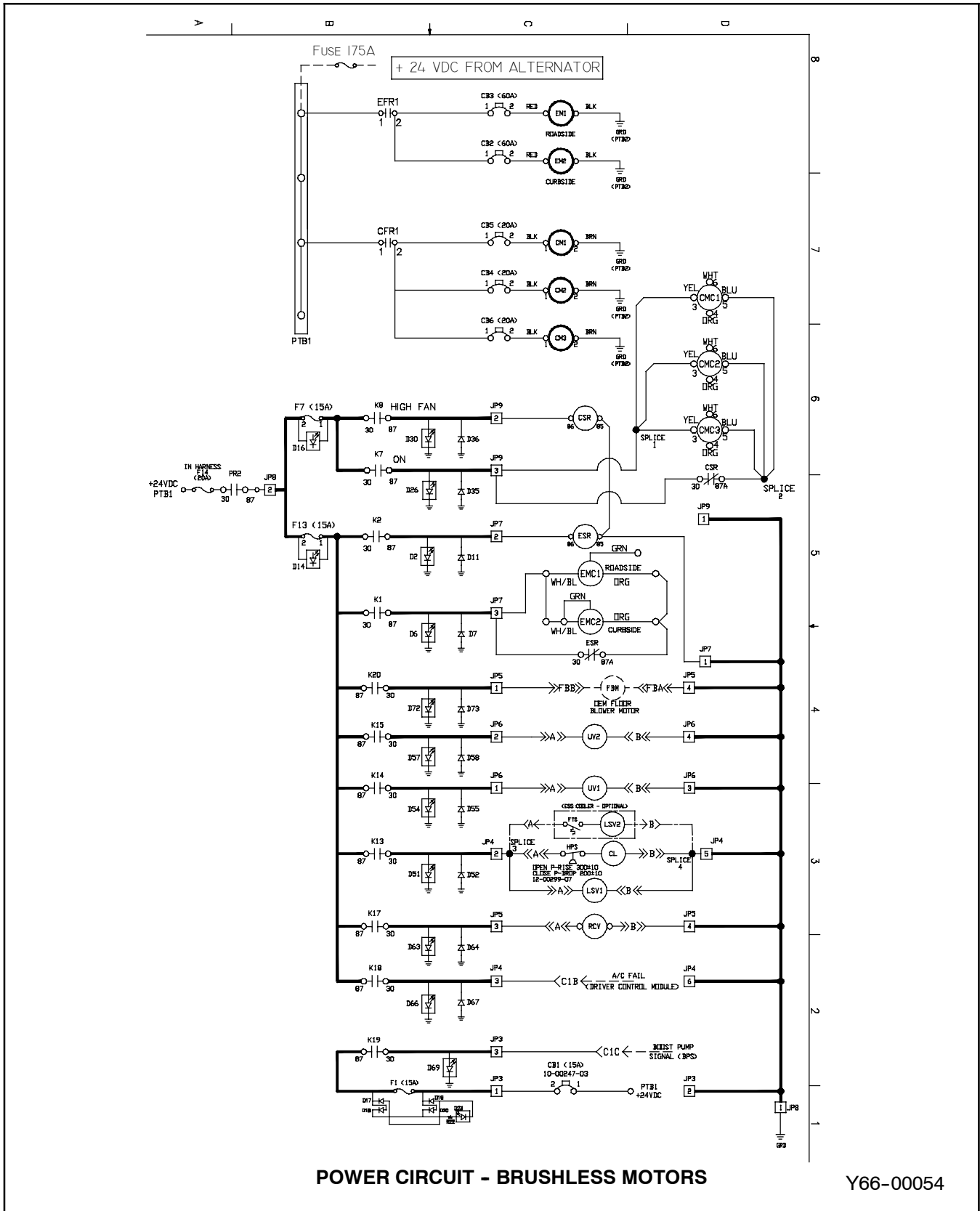

Figure 5-13. Wiring Schematic - Power Circuit - Y13-R3501-01



INDEX

A

Air Filter	4-11
Alarm	2-6, 3-1
Alarm Clear	3-1
Alarm Codes	3-1
Alarm Queue	3-1
Ambient Lockout	1-12

B

Boost Pump	2-4
------------	-----

C

Circuit Breaker	1-12
Clutch	2-5, 4-12
Compressor	1-5, 1-10, 4-11
Compressor Oil	1-10
Condenser Fan	2-5
Condenser Fan Motor	4-16, 4-17
Condensing Section	1-1
Control Panel	1-9, 1-10
Cooling Mode	2-3

D

DESCRIPTION	1-1
Diagnostics	2-2, 2-6
Discharge Pressure	2-4

E

Evacuation	4-5
Evacuation, One Time	4-6
Evacuation, Triple	4-6

Evaporator	1-4
Evaporator Fan	2-4

F

Fan Motor Operation Sequence	2-4
Fan Motor Operation Sequence, Brushless Motors	2-5
Fan Motor Operation Sequence, Permanent Magnet and Wound Field Motors	2-5
Filter-Drier	1-14, 4-8
Filter-Drier Inlet Valve	1-14
Fresh Air Connection	1-5
Fuse	1-12

H

Heating Cycle	1-13
Heating	2-3
High Pressure Switch	1-10, 1-11, 4-7
Hour Meter	2-6

L

Liquid Line Solenoid	1-14, 2-6, 4-8
Liquid-Suction Heat Exchanger	1-14
Logic Board	1-9, 2-1, 3-1, 4-21
Low Pressure Switch	1-10, 1-11, 4-7

M

Maintenance Schedule	4-1
MANIFOLD GAUGE SET	4-2
Micromate Control Panel	2-1, 3-1
Modes Of Operation	2-2

N

Noncondensibles, Check For	4-7
----------------------------	-----



INDEX

O

Oil Level, Check Compressor 4-13
Operating Controls 1-5
Operating Instructions 2-1

P

Pre-Trip Inspection 2-2
Pressure Transducer 1-11, 4-15
Pump Down 4-3, 4-4

R

Refrigerant Charge 1-10, 4-3, 4-5, 4-6, 4-7
Refrigerant Removal 4-4, 4-5
Refrigeration Cycle 1-13
Relay Board 1-8

S

Self Diagnostics 3-1
Service Valves 4-2
Shaft Seal Reservoir 4-11
Suction Pressure 2-4
Superheat 4-10

System Parameters 2-6
System Shutdown 2-2
System Start-up 2-1

T

Temperature Control 2-3, 2-4
Temperature Pressure Chart 4-22
Temperature Sensor 1-11, 4-14, 4-15, 4-17, 4-18,
4-19, 4-20
Thermostatic Expansion Valve 1-10, 1-14, 4-9
Troubleshooting 3-1
Troubleshooting No CAN Communication 3-2

U

Unit Assembly 1-1
Unloader Control 2-4

V

Vent Mode 2-4

W

Water Temperature Switch 1-10
Wiring Schematics 5-1

Every driver deserves the best possible vehicle climate with MCC products

MCC provides exceptional performance in mobile climate comfort.



www.mcc-hvac.com

Member of MCC Group • Certified ISO 9001 and ISO 14001.
Specifications subject to change without notice. MCC is a registered trademark.