



## Rooftop Condenser **K-410**

Our K-410 high capacity roof mount condenser has been specifically engineered for use in commercial, light transit and school bus applications. This unit is the perfect marriage of sleek, low profile European styling and American innovation.

The rugged fibreglass cover shrouds the high strength steel and lightweight aluminum structure underneath, while allowing complete service access without cover removal.

The highly adjustable mounting rails are designed to attach this unit to any exterior roof radius without leaving visually unsightly gaps between roof and unit cover.

MCC's innovative introduction of the roofmount condenser series to the North American bus market has given body builders the opportunity to free up skirt place for a variety of options including CNG tanks, wheelchair lifts and luggage compartments, while maintaining an aerodynamic exterior appearance to your vehicle.

The roofmount condenser is the answer to severe road salt corrosion and high radiant ground temperature environments.



### Features

- Half the height of current models
- Lower condensing temperatures and pressures than skirt-mounted condensers provide enhanced cooling and better efficiency
- Adaptable to 12V and 24V applications
- Corrosion resistant, lightweight housing
- Lightweight, durable fiberglass cover
- Optional fan winter guard kit

# Rooftop Condenser **K-410**

MCC Roof Mount Condensers

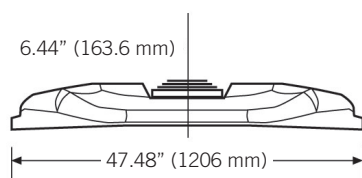
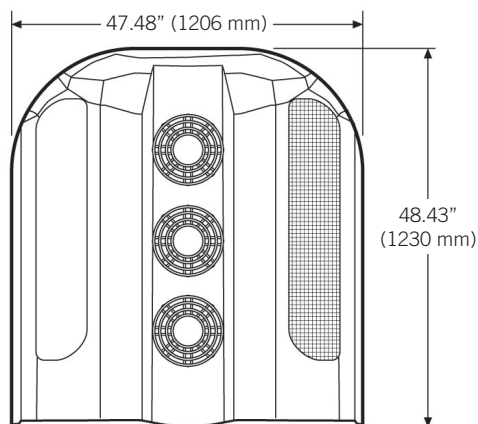

## Technical Data

Capacity	82000 Btu/hr (24 kW) IMACA <sup>[1]</sup> 57000 Btu/hr (16.7 kW) ARI <sup>[2]</sup>
Air flow	1700 CFM (288 m <sup>3</sup> /hr)
Condenser coil	Two coils each, two rows deep with internally enhanced copper tubes expanded into aluminium fins
Condenser fans	3
Fan motors	Totally enclosed, pancake-style, permanent-magnet type with extended-life permanently lubricated, sealed bearings and 4-pole graphite brushes
Max amperage requirement	23 amps @ 13.5 VDC; 11 amps @ 24 VDC
Safety controls	High refrigerant pressure cut-out 400 psi (28 bar); cut-in 300 psi (21 bar)
Filter dryer	16 in <sup>3</sup> (262 cm <sup>3</sup> )
Weight	Installed weight 80 lbs (36.3 kg)
Available color	Gel coat white

[1] IMACA conditions: 100°F (38°C) / 90°F (32°C) / 50% RH

[2] ARI conditions: 95°F (35°C) / 80°F (27°C) / 50% RH



### Mobile Climate Control