



Compressor Bock **Semi-hermetic HG**

Powerful lightweight semi-hermetic compressors for mobile application

The product of extensive experience in the transport refrigeration and air conditioning market, the Bock HG34 is a V-4 semi-hermetic compressor that offers world class performance and durability. It is available in three displacement levels. The HG34 is designed to operate at a variable speed across a wide range of frequency driven by a suction gas-

cooled 3-phase induction motor on a common shaft. Along with an optional unloader on one cylinder bank, the compressors offers the most versatile and most energy saving method of capacity control in the industry. The Bock Compressors offer many valued features sought after in the transport air conditioning market.

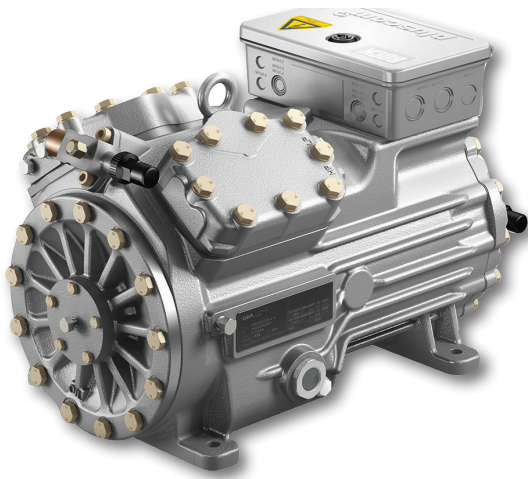

HG34

Features

- High efficiency and reliable operation
- Compact and lightweight aluminum design
- Robust lubrication system and bearing
- Extremely low noise and vibration
- Optimized for R134a, R-407C
- Special K-valve plate optimized for air conditioning applications

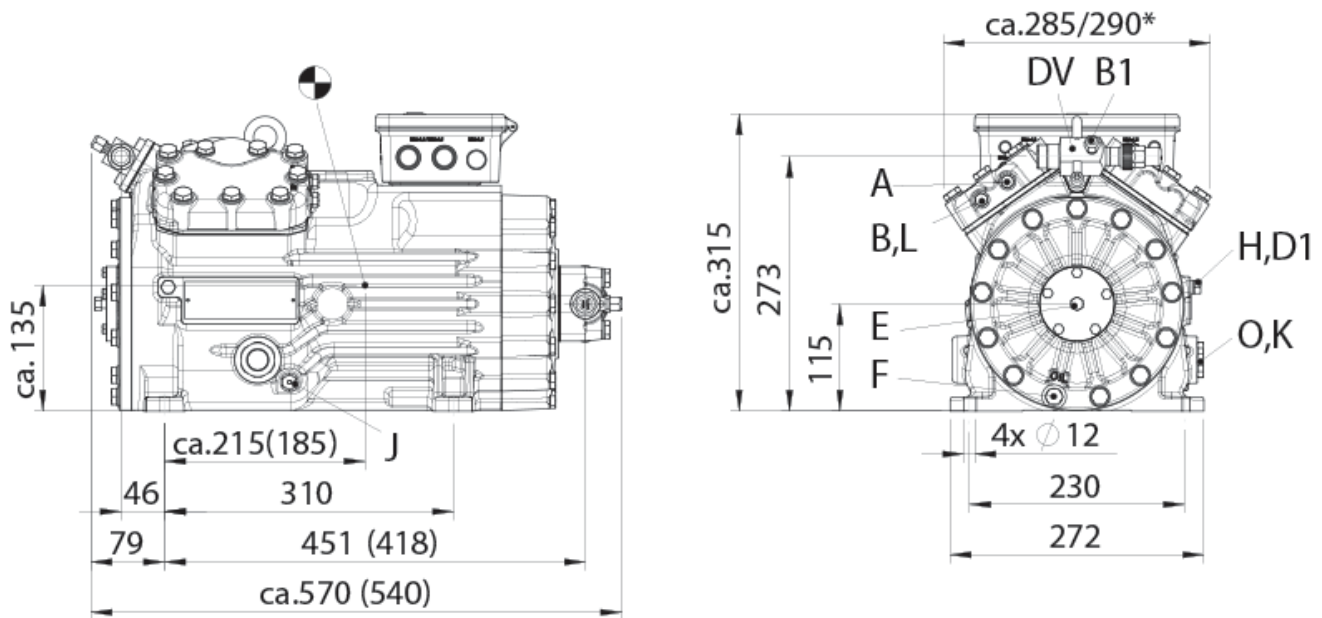

Technical Data

Semi-hermetic HG	
Compressor type	Reciprocating, 4-cylinder, V-arrangement
Swept volume	255 - 315 - 380 cm ³ (15.6 - 19.2 - 23.2 in ³)
Speed (frequency) range	(N _s) 900 - 3600 min ⁻¹ (15 - 60 Hz)
Sense of rotation	Bi-directional (insensitive to phase sequence)
Motor type	3-phase induction, 2-pole
Motor voltage	400 - 3 - 50 (480 - 3 - 60) Other voltages available
Refrigerant	R134a, R407C
Lubrication	Forced, bi-directional gerotor pump
Oil type and charge	POE, 1300 cm ³ (44 oz)
Dimensions (L x W x H)	570 x 290 x 315 mm (22.4 x 11.4 x 12.4 in)
Weight (without clutch)	59 kg (130 lbs)

