



## Compressor **Bock<sup>1</sup> FKX40 and FKX50 Bus Air Conditioning**

# World class performance, compact and robust design

The product of extensive experience in the transport refrigeration and air conditioning market, the Bock FKX40 and FKX50 open drive compressor models offer world class performance and durability. The 4 cylinder FKX40 and

6 cylinder FKX50 are available in a variety of displacement levels and can be sized to meet a wide range of applications. The Bock Compressors offer many valued features sought after in the transport air conditioning market.

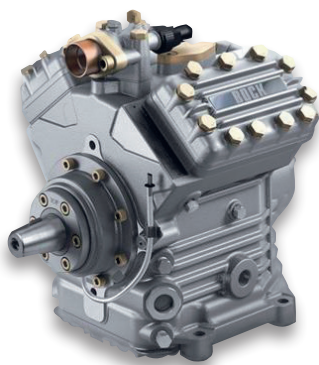

FKX40

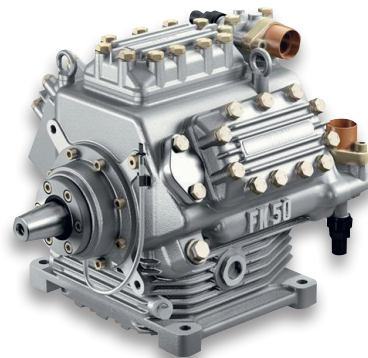

FKX50

### Features

- High efficiency and reliable operation
- Lightweight and compact aluminum design
- Robust lubrication system and bearings
- Forced-feed lubrication
- Proven shaft seal designed for long life and ease of service
- Optimized for R134a, R407C
- Special K-valve plate optimized for air conditioning applications
- Practical drain through a feely accessible flexible tube (no dismantling of the clutch necessary)

# Compressor Bock<sup>1</sup> FKX40 and FKX50 Bus Air Conditioning

MCC Compressors

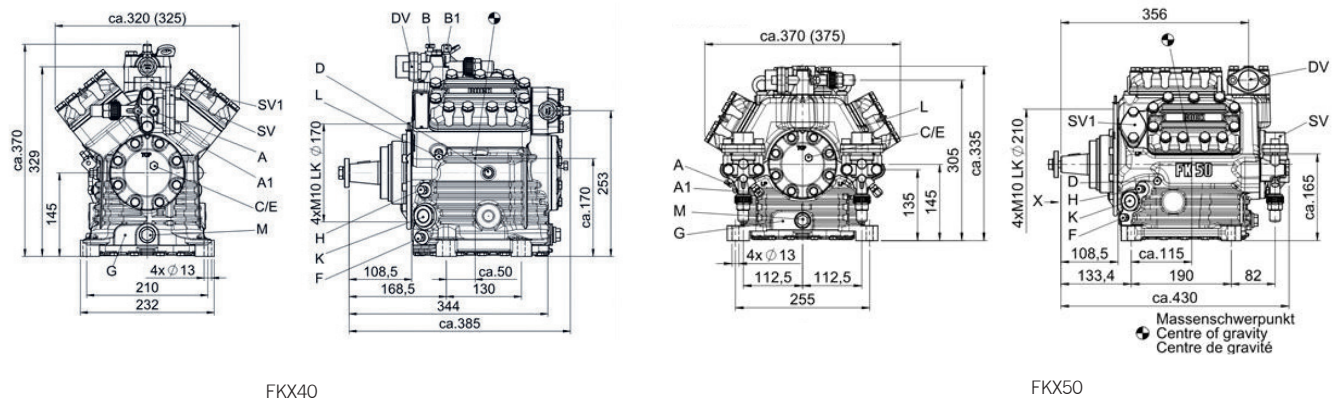

FKX40

FKX50

## Technical Data

|                         | Bock <sup>1</sup> FKX40                                   | Bock <sup>1</sup> FKX50                                   |
|-------------------------|---|---|
| Rotation                | CW/CCW  | CW/CCW  |
| Max speed               | 3500 rpm  | 3500 rpm  |
| Clutch coil             | 24 VDC  | 24 VDC  |
| Displacement            | 39.7 in <sup>3</sup> (650 cm <sup>3</sup> /rev)           | 50.7 in <sup>3</sup> (830 cm <sup>3</sup> )               |
| Number of cylinders     | 4   | 6   |
| Refrigerant             | R134a, R407C  | R134a, R407C  |
| Pulleys                 | 2-SPB, 2 – 5 V  | 2-SPB, 2 – 5 V  |
| Oil charge              | 67.6 oz (2000 cm <sup>3</sup> )                           | 67.6 oz (2000 cm <sup>3</sup> )                           |
| Dimensions (L x W x H)  | 15.2" (386.08 mm) x 12.8" (325.12 mm) x 14.6" (370.84 mm) | 16.9" (429.26 mm) x 14.8" (375.92 mm) x 13.2" (335.28 mm) |
| Weight (without clutch) | 73 lbs (33 kg)  | 93 lbs (42 kg)  |

<sup>1)</sup> Bock Compressors are now part of the Global GEA Companies

