



VIII. Heaters

Heater **Whisper UW-9**

Very compact heater

Having the same profile as the UC-9 convector, MCC heater whisper UW-9 is the ideal wall mounted heater when extra heat output is required.

As a part of the UC-9 family, the UW-9 heater is compact, it is also highly customizable suitable for motor coaches

and transit buses. The unit consists of heat exchanger with configurable water connections, two speed fans.

The UC-9 can be also be used in as a standalone heating unit or in combination with other heaters and convectors. An electrostatic or mesh filter can also be added as an option.

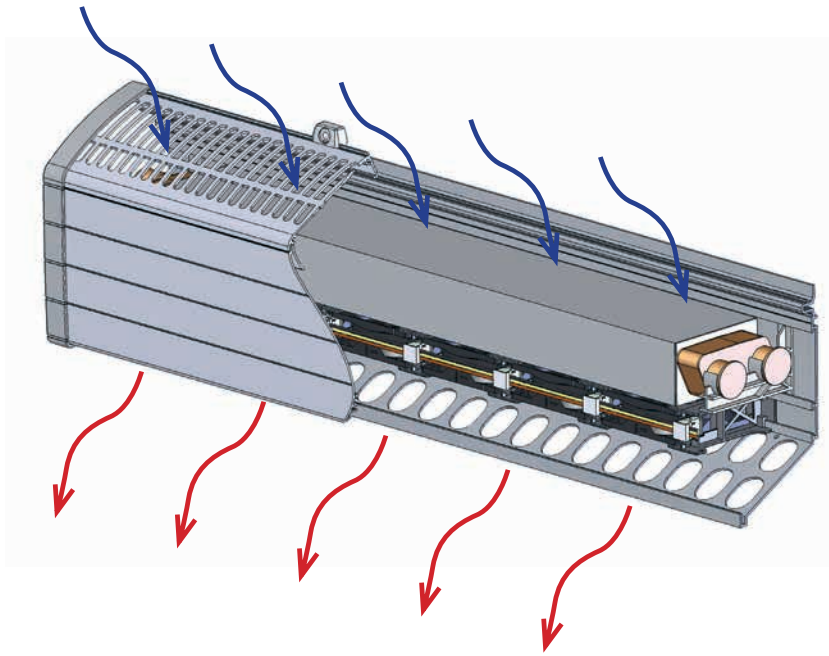

Features

- Smooth air distribution
- Rugged design
- Suitable for sloping floors
- Flexible design (3-18 fans)
- Two speed long life fans
- Lightweight

Dimensions

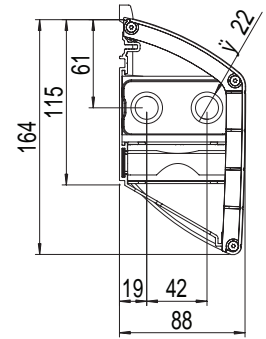
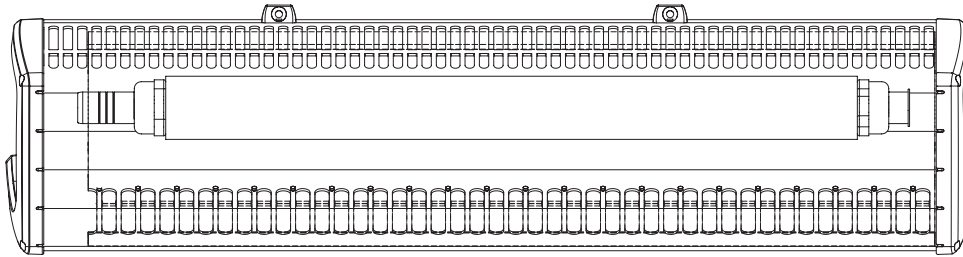

Dimensions in mm

Technical Data

Heat	15013 Btu/hr (4.4 kW) Q_{80}	18767 Btu/hr (5.5 kW) Q_{100}
Air flow @ 28V (6 fans)	61 CFM (182 m ³ /h)	
Coolant connection	Copper Ø 0.9 (22 mm)	
Voltage	12 or 24V	
Height	6.5" (165 mm)	
Lengths	10-79" (250-2000 mm)	
Cover sections	Anodized aluminum	

* The Q_x value stands for the temperature difference between the water inlet temp and the air temp in the room where the heat exchanger is. For instance water inlet temp +80°C and air temp +20°C is known as Q_{60} .

Heater **Whisper 3C, 7C and 12C**

High performance heating system

The Whisper 3C, 7C and 12C heaters are units designed for high output.

Whisper 3C available only in 24V, 7C and 12C are available in 12V and 24V versions. Thanks to its modular

design, piping can be mounted on either left or right side for easy installation. 3C, 7C and 12C are electro-magnetic interference conformance (EMC) approved according to 72/245/EG including revision 2005/83/EG.



Whisper 3C



Whisper 7C & 12C

Features

- Design for buses, off-road and marine applications
- High performance
- Rugged design
- Piping can be mounted either left or right side
- Can be mounted in horizontal or vertical position

Whisper 3C

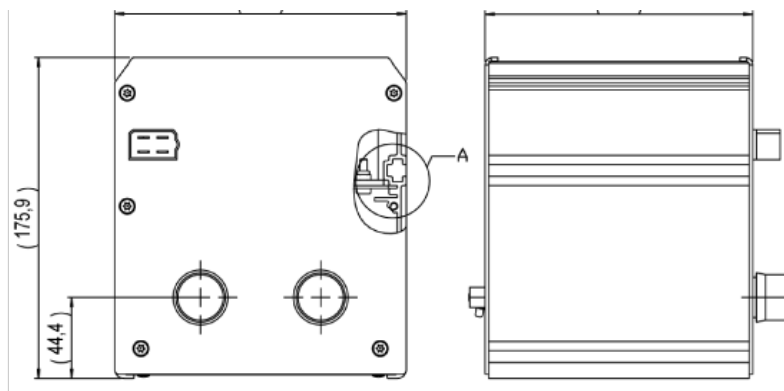

Whisper 7C & 12C

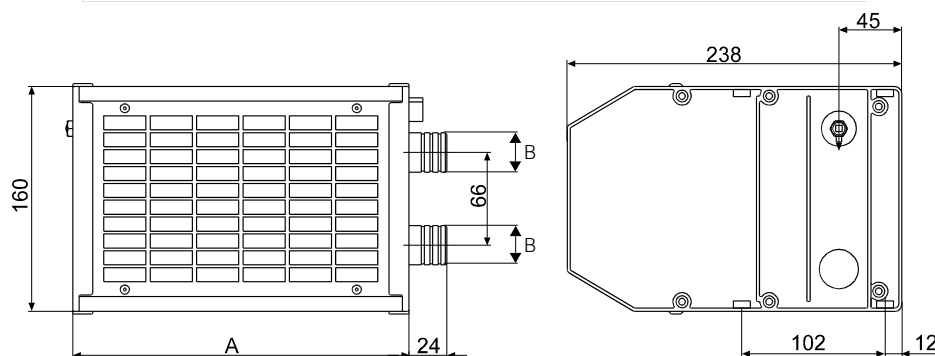

Technical Data

	3C	7C	12C
Heat @ 24V	10577 Btu/hr (3.1 kW) Q_{80} ^[1]	24567 Btu (7 kW) Q_{80} ^[1]	39240 Btu (11.5 kW) Q_{80} ^[1]
Heat @ 12V	N/A	21496 Btu (6 kW) Q_{80} ^[1]	35827 Btu (10.5 kW) Q_{80} ^[1]
Air flow @ 24 V	102 CFM (175 m ³ /h)	212 CFM (360 m ³ /h)	309 CFM (525 m ³ /h)
Air flow @ 12 V	N/A	182.5 CFM (310 m ³ /h)	256 CFM (435 m ³ /h)
Max current @ 24 V (A)	2.6 Amp	4.3	6.2
Max current @ 12 V (A)	N/A	8.3	11.7
Hose connection	22/28 mm	22/28 mm	22/28 mm
Weight	6 lbs (2.6 kg)	11.2 lbs (5.1 kg)	14.5 lbs (6.6 kg)
Depth	6.3" (160 mm)	9.3" (238 mm)	9.3" (238 mm)
Height	6.9" (175 mm)	6.3" (160 mm)	6.3" (160 mm)
Length	5.7" (147 mm)	9.4" (239 mm)	14" (356 mm)
Electrical connection	4 pin AMP 180901-0 connector		
Heat exchanger	Copper fins with brass and plates		
Casing	Natural anodised aluminium sections		
Standard colour	Natural aluminium		
Accessories	Different types of hoses, brackets etc, see product sheet		

[1] The Q_x value stands for the temperature difference between the water inlet temp and the air temp in the room where the heat exchanger is. For instance water inlet temp +80°C and air temp +20°C is known as Q_{60} .

Heater **Whisper K-200**

Economical Compact Heater

MCC Whisper K-200 compact heating unit is a part of the Whisper 200 family, its compact size means that it can be mounted anywhere. The whisper K-200 consists of a heat exchanger and four brushless fans (12VDC or 24VDC) with

long life bearings for quiet operation. All components are mounted in a rugged anodized aluminum case with integrated mounting bracket for simple installation.

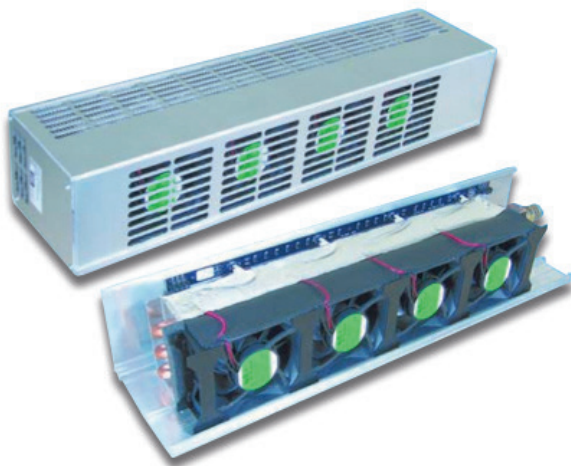

Features

- Heater system for interior heating in buses with water/ glycol based heating systems
- Piping can be mounted either left or right side
- Smooth air distribution
- Compact and light weight design
- Long life brushless fans

Dimensions

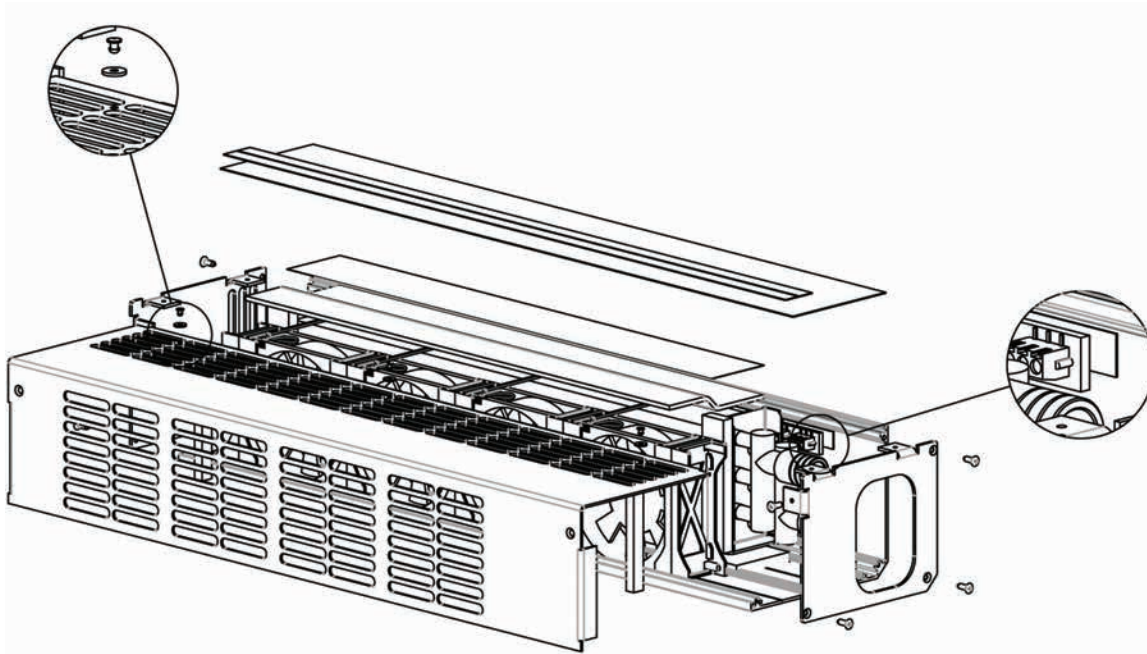

Dimensions in mm

Technical Data

Operating voltage/Maximum operating voltage	24/28 VDC	
Power consumption	0.8A/19W	
K 200 meets the requirements according to:	Low Voltage Directive 73/23/EEC EMC Directive 89/336/EEC CE Marking Directive 93/68/EEC	
Standard connection	Direct to circuit board	Black=Ground Red=High speed Blue=Low speed
Heat ^[1]	8190 Btu/hr (2.4 kW) Q_{60}	13649 Btu/hr (4.0 kW) Q_{100} AMP plug P/N 1-350346-0
Air flow	103 CFM (175 m ³ /h)	
Coolant connections	Connections to K200 are with Ø 0.9" (22 mm) hoses.	

[1] The Q_x value stands for the temperature difference between the water inlet temp and the air temp in the room where the heat exchanger is. For instance water inlet temp +80°C and air temp +20°C is known as Q_{60} .

Heater **Whisper 200/2-3-5 fans**

High performance with unique flexibility

The Whisper 200 family is a highly customizable wall mounted heating unit designed for motor coaches and buses. It consists of a coolant type heat exchanger with various fan configurations in 24V or 12V. The Whisper 200 can be customized in different configurations, with two to five fans and

front or rear water connections. It can be used as stand alone heating source or in combination with convectors.

The Whisper 200 is EMC approved according to directive 72/245/EEG including rev 2006/28/EG.

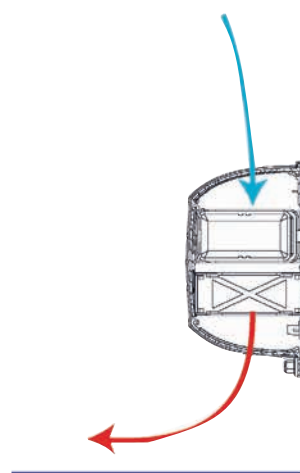

Features

- Heater blower system for buses with water/glycol based heating systems
- Smooth air distribution
- Whisper quiet operation
- Many configurations possible thanks to flexible design
- Long life two speed fans
- Low weight

Dimensions

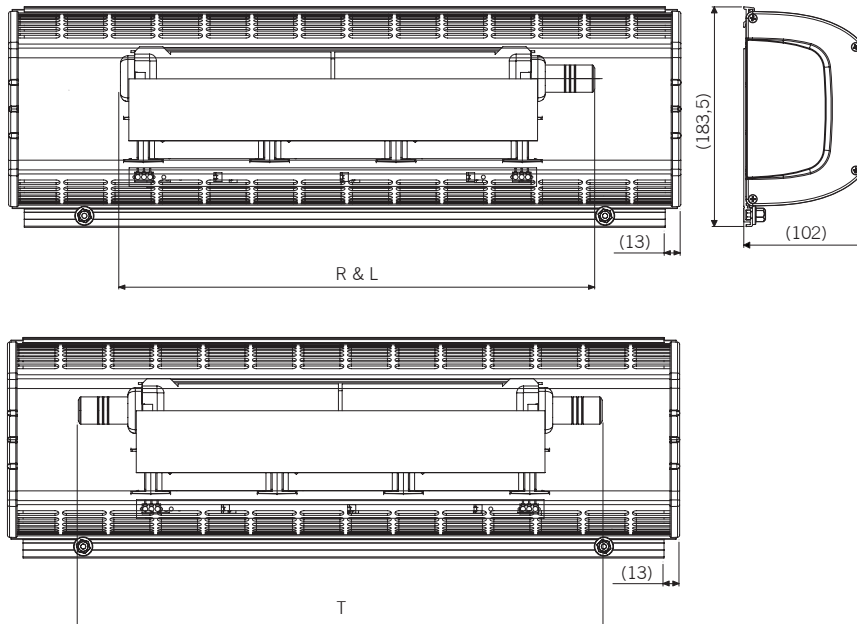

Dimensions in mm

Variant	2 Fans	3 Fans	5 Fans
Left or Right Connection (R&L)	10.2" (260 mm)	15.1" (383 mm)	23.3" (591 mm)
Through water Connection (T)	11.8" (300 mm)	17" (423 mm)	25" (631 mm)

Technical Data

	2 Fans	3 Fans	5 Fans
Heat	6824 Btu/hr (2 kW) Q_{80}	9554 Btu/hr (2.8 kW) Q_{80}	16037 Btu/hr (4.7 kW) Q_{80}
	8530 Btu/hr (2.5 kW) Q_{100}	11942.5 Btu/hr (3.5 kW) Q_{100}	20131 Btu/hr (5.9 kW) Q_{100}
Air flow	153 CFM (260 m ³ /h) \emptyset	92 CFM (156 m ³ /h)	153 CFM (260 m ³ /h)
Heat exchanger water connection	\emptyset 0.9" (22 mm)	\emptyset 0.9" (22 mm)	\emptyset 0.9" (22 mm)
Voltage	12 or 24V	12 or 24V	12 or 24V
Depth	4" (102 mm)	4" (102 mm)	4" (102 mm)
Height	7.2" (183.5 mm)	7.2" (183.5 mm)	7.2" (183.5 mm)
Length	According to request, see Whisper 200 product configuration		
Cover sections	Anodized aluminum		

* The Q_x value stands for the temperature difference between the water inlet temp and the air temp in the room where the heat exchanger is. For instance water inlet temp +80°C and air temp +20°C is known as Q_{60} .

Electric DC Voltage Heater

PTC heating element with MCC electronic temperature stabilization and safety control

This newly designed mini electric heater with fully integrated controls can be used where space is at a premium. Small and economical, but powerful for its size, it is perfect for electrically powered compact cabins, forklifts, mini

construction equipment, or as an aftermarket replacement. Simple and easy to instal, all that is needed is an electrical connection and a power supply. The heater casing is made of durable powder coated metal to withstand rigors of daily use.



Features

- Compact design with low weight
- High efficiency and quiet operation
- Integrated speed and temperature control
- Four direction airflow louvers
- Flexible mounting for bottom or side
- No maintenance other than filter cleaning
- Easy access and reusable filter
- Industry leading power management
- MCC optimized electronic controller
- CAN (J1939) capability

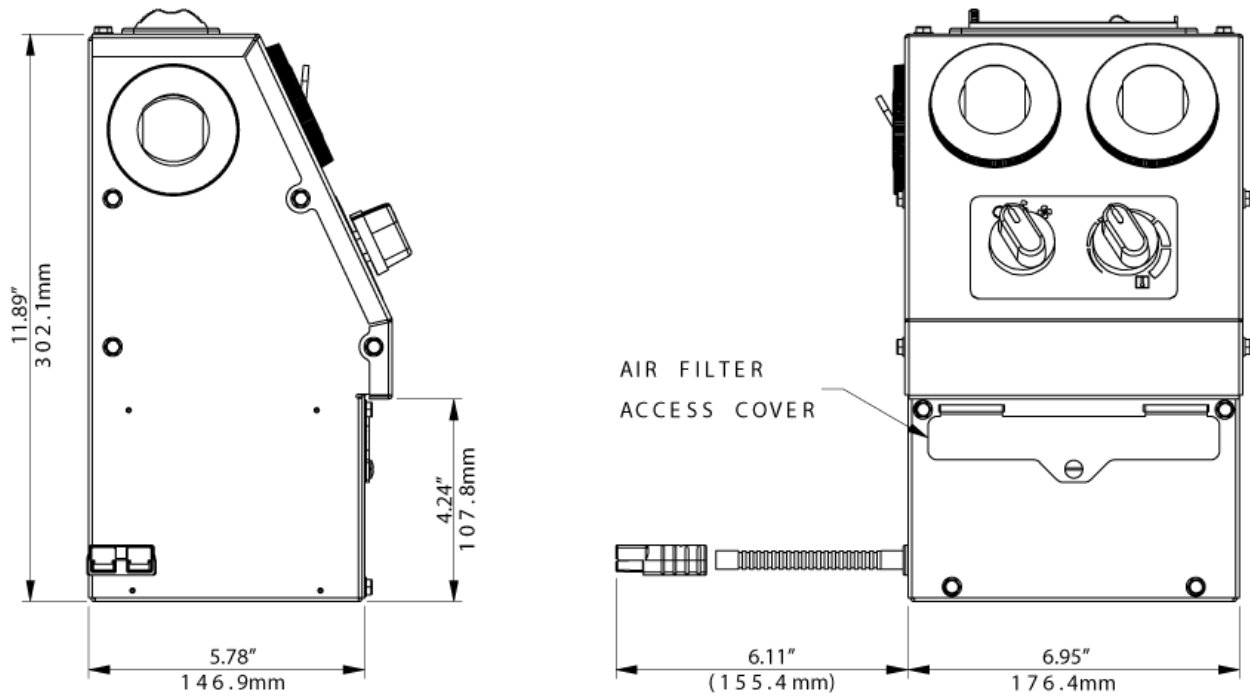

Technical Data

Airflow	~175 CFM (297 m ³ /h)
Heating Capacity	5500 Btu/hr (1600 Watts)
Noise (SPL)	60 dba at maximum speed setting
Maximum discharge temperature	60° C (140° F)
Maximum surface temperature	60° C (140° F)
Voltage	36/48/80 VDC
Amperage	~ 45/36/20 Amps
Connector	Anderson Power 2-W SB 50 (BLUE)

Fan Heater Model 201

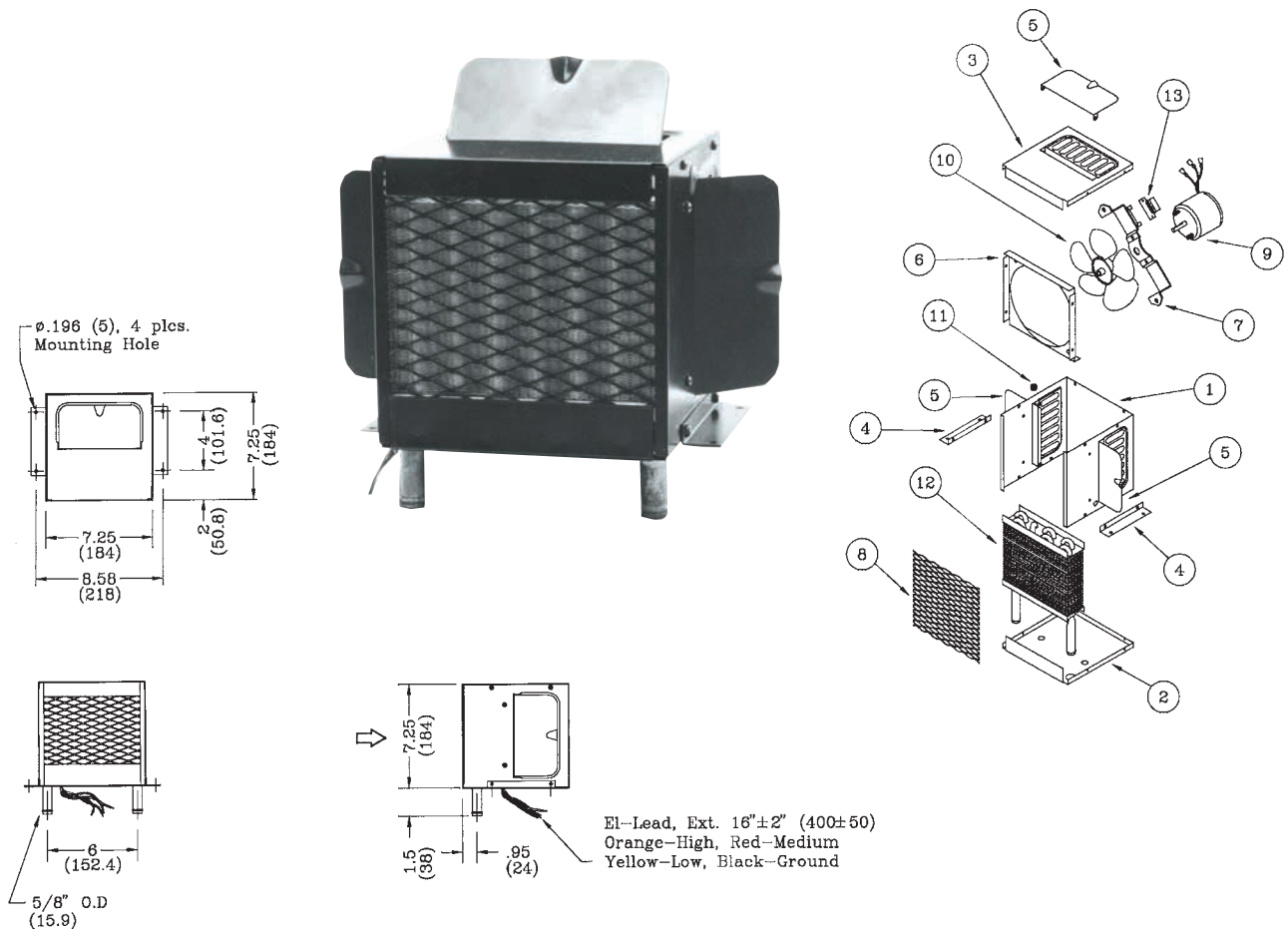

Part Descriptions: Specifications

Part No.	No.	Part No.	Description	No.	Part No.	Description	
12-0103		1	24-0135	Casing	8	24-0172	Coil Protector
12-0102		2	24-0136	Cover	9	25-0105	Motor 12V
		3	24-0137	Cover		25-0107	Motor 24V
		4	24-0133	Mounting Bracket	10	25-0023	Fan
		5	23-0009	Door (3 Pcs.)	11	28-0014	Grommet
		6	24-0138	Venturi	12	22-0042	Heater Coil
		7	24-0113	Motor Bracket	13	25-0095	Resistor

Specifications

Heating -13500 Btu/hr (3960 W)
 Air Flow -185 CFM (315 m³/h)
 Current -5.8 Amps/12V
 -2.9 Amps/24V
 Weight -7.5 lbs. (3.4 kg)
 3-Speed operated motor.

Features

The compact design of the 201 is ideal for dash or under seat mounting. Air is delivered to sides of unit and can be controlled by air doors.

Fan Heater Model 209

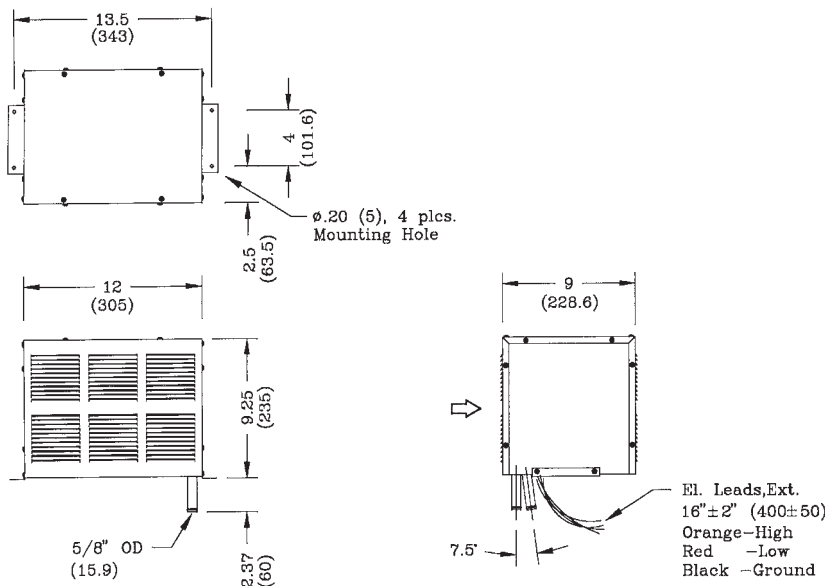
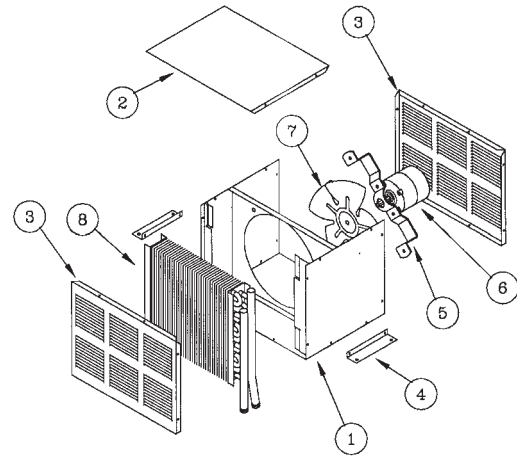

Part Descriptions: Specifications

Part No.		No.	Part No.	Description
12-0903	Heater 12V	1	24-0353	Casing
12-0904	Heater 24V	2	24-0354	Cover
		3	24-0355	Grill
		4	24-0133	Mounting Bracket
		5	24-0223	Motor Bracket
		6	25-0344	Motor 12V
			25-0107	Motor 24V
		7	25-0121	Fan C.W. (8")
		8	22-0029	Heater Coil

Specifications

- Heating - 32000 Btu/hr (9380 W)
- Air Flow - 350 CFM (595 m³/h)
- Current - 12 Amps/12V
- 6 Amps/24V
- Weight - 25.5 lbs. (11.5 kg)
- 2-Speed motor.

Features

High capacity design can be used as auxiliary heater for bus, or as stand alone cab heater.

Fan Heater Model 211

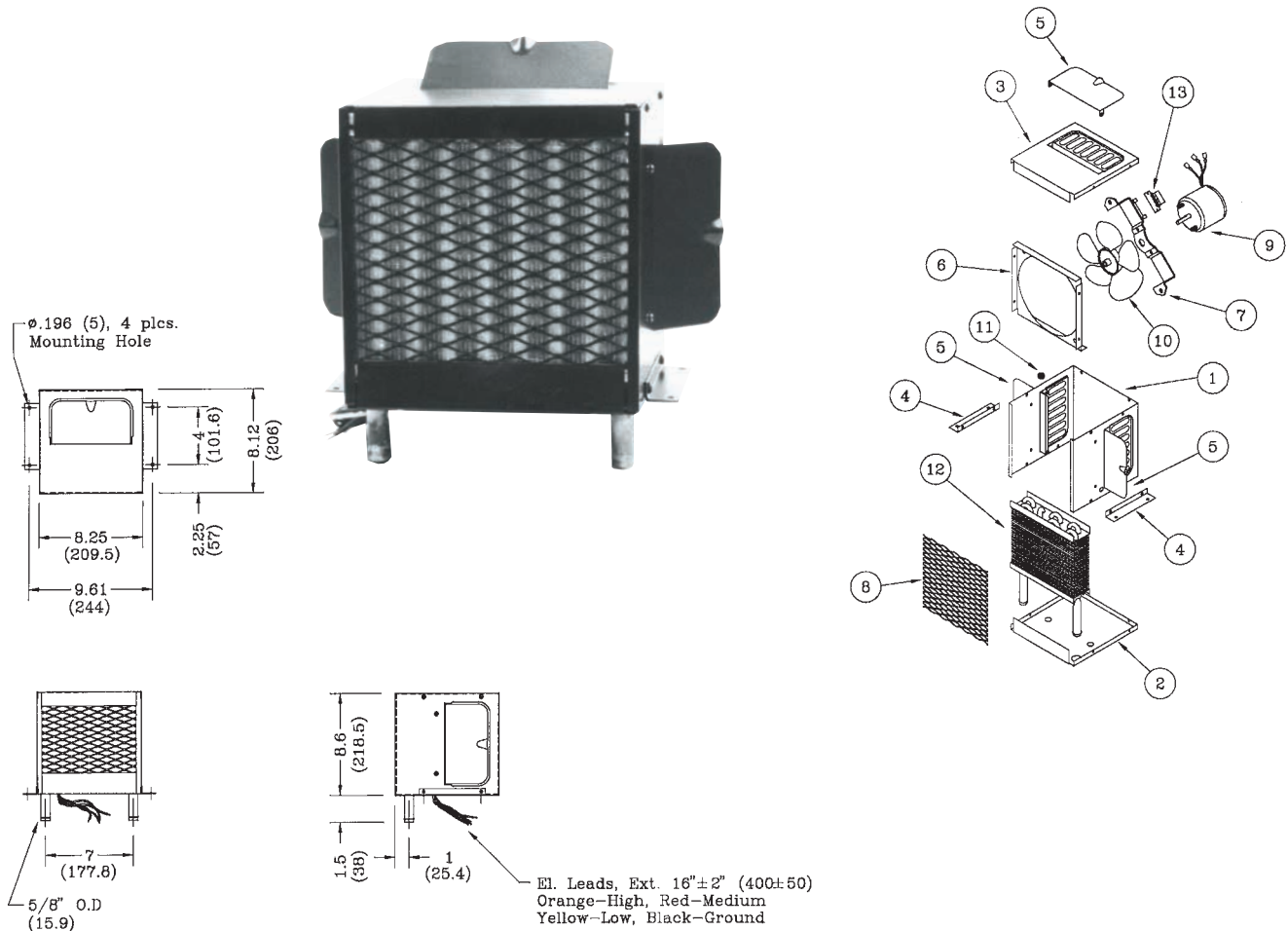

Part Descriptions: Specifications

Part No.	No.	Part No.	Description	No.	Part No.	Description
12-1103		12-1104	Heater 12V Heater 24V	1	24-0140	Casing
				2	24-0142	Cover
				3	24-0143	Cover
				4	24-0133	Mounting Bracket
				5	23-0009	Door (3 Pcs.)
				6	24-0141	Venturi
				7	24-0113	Motor Bracket
				8	24-0171	Coil Protector
				9	25-0105	Motor 12V
					25-0107	Motor 24V
				10	25-0023	Fan
				11	28-0014	Grommet
				12	22-0023	Heater Coil
				13	25-0095	Resistor

Specifications

Heating	-21000 Btu/hr (6150 W)
Air Flow	-265 CFM (450 m ³ /h)
Current	-5.8 Amps/12V -2.9 Amps/24V
Weight	-9 lbs. (4 kg)

3-Speed motor.

Features

Similar design as our popular 201. The 211 offers a higher quality heater with controllable air doors.

Fan Heater Model 213

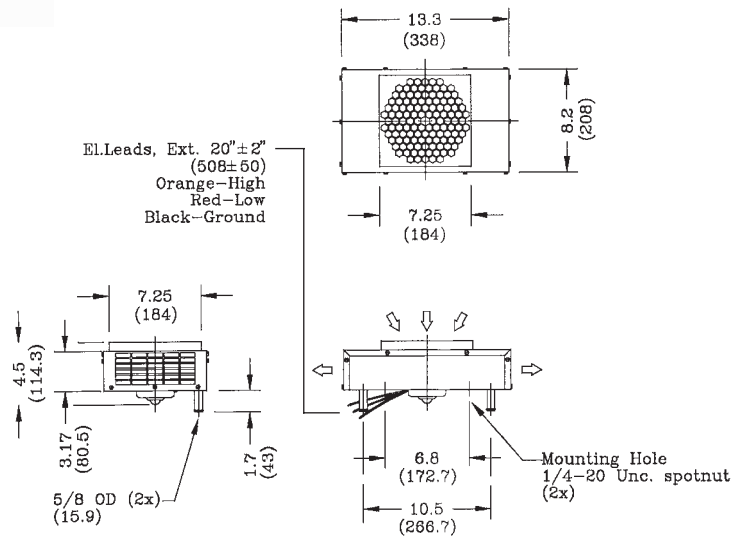
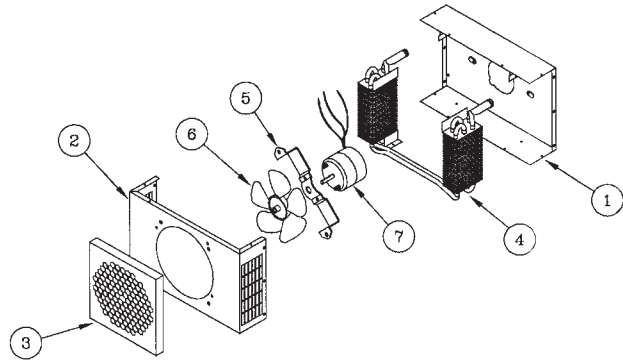

Part Descriptions: Specifications

Part No.	No.	Part No.	Description
12-1301		Heater 12V	
12-1302		Heater 24V	
Specifications			
Heating	-	12500 Btu/hr (3660 W)	
Air Flow	-	150 CFM (255 m ³ /h)	
Current	-	5.8 Amps/12V	
	-	2.9 Amps/24V	
Weight	-	7 lbs. (3.2 kg)	
2-Speed motor.			
	1	24-1120	Casing
	2	24-1121	Cover
	3	25-1122	Fan Guard
	4	22-0196	Heater Coil
	5	24-0110	Motor Bracket
	6	25-0023	Fan
	7	25-0105	Motor 12V
		25-0107	Motor 24V

Features

Slim design allows for mounting in tight spots. Can be wall mounted with heater connectors exiting the back of the unit.

Fan Heater Model 214

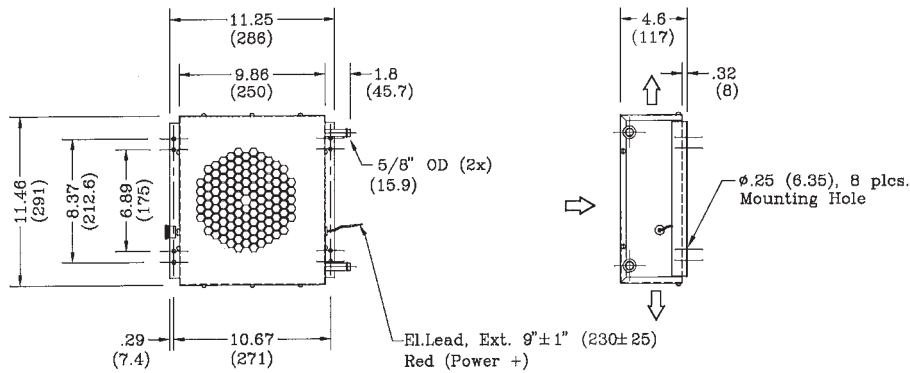
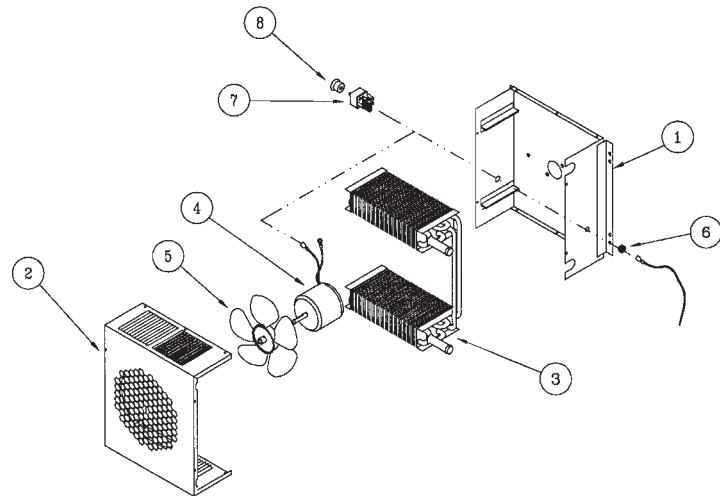
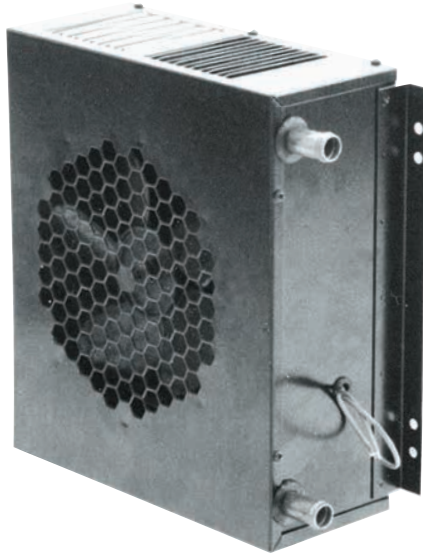

Part Descriptions: Specifications

Part No.	No.	Part No.	Description
12-1411	1	24-0042	Casing
12-1412	2	24-0043	Cover
	3	22-0073	Heater Coil
	4	25-0039	Motor 12V
		25-0043	Motor 24V
	5	25-0015	Fan
	6	28-0014	Grommet
	7	25-0028	Switch
	8	25-0067	Knob

Specifications	
Heating	-18500 Btu/hr (5420 W)
Air Flow	-175 CFM (300 m ³ /h)
Current	-4.4 Amps/12V
	-2.2 Amps/24
Weight	-9 lbs. (4 kg)
3-Speed motor and internally grounded.	

Features

With a larger capacity than the 213, the 214 offers flexible mounting solutions for wall mount situations. Fittings exit the side of the 214.

Fan Heater Model 216

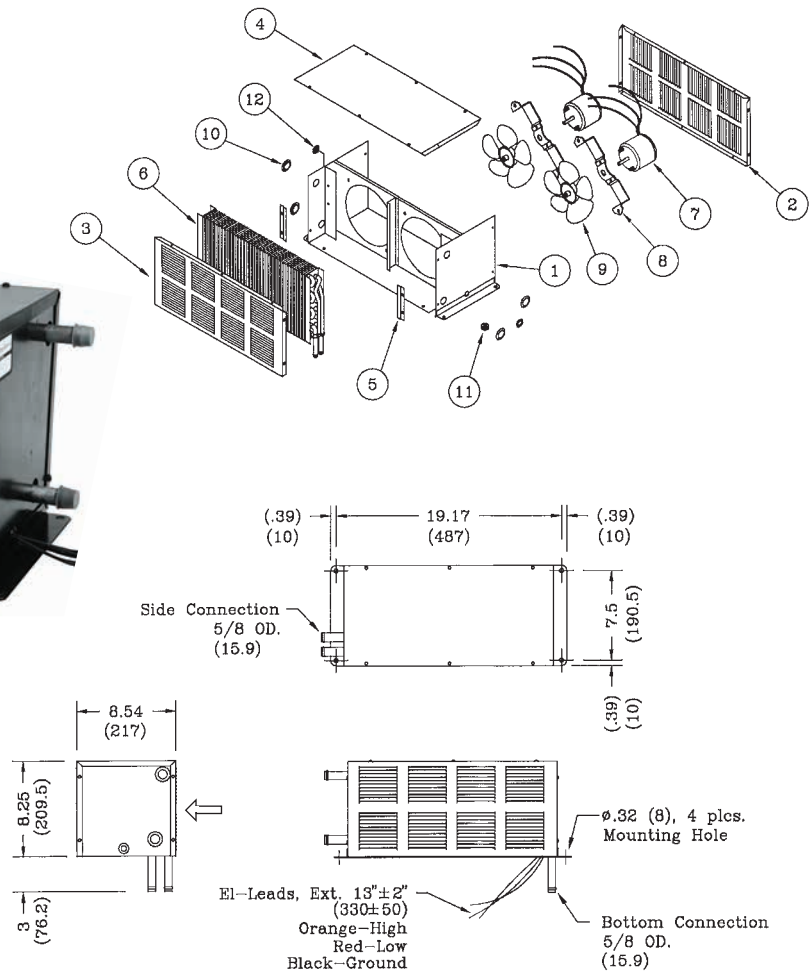

Part Descriptions: Specifications

Part No.		No.	Part No.	Description	No.	Part No.	Description
12-1601	Heater 12V -R.H.C.	1	24-0130	Casing	7	25-0105	Motor 12V
12-1602	Heater 24V -R.H.C.	2	24-0131	Grill (Inlet)		25-0107	Motor 24V
12-1621	Heater 12V -B.C.	3	24-0132	Front (Outlet)	8	24-0110	Motor Bracket
12-1622	Heater 24V -B.C.	4	24-0105	Cover	9	25-0023	Fan
		5	24-0146	Coil Support	10	28-0010	Snap-in Plug
			24-0162	Coil Support (B.C.)	11	28-0004	Grommet
			24-0163	Coil Support (B.C.)	12	28-0011	Snap-in Plug
		6	22-0038	Heater Coil			
			22-0039	Heater Coil (B.C.)			

Specifications

Heating	-42000 Btu/hr (12300 W)
Air Flow	-500 CFM (850 m ³ /h)
Current	-11.6 Amps/12V -5.8 Amps/24V
Weight	-18.5 lbs. (8.4 kg)
2-Speed motor.	

Features

High capacity heating solution for buses, fire trucks and truck bodies. The 216 delivers maximum performance for large capacity heating requirements.

Fan Heater Model 222

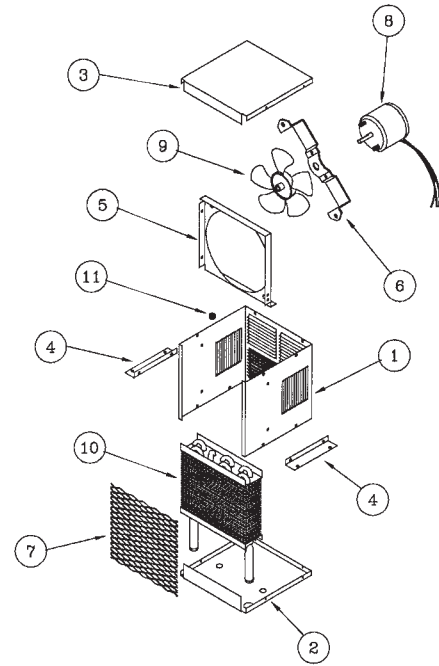
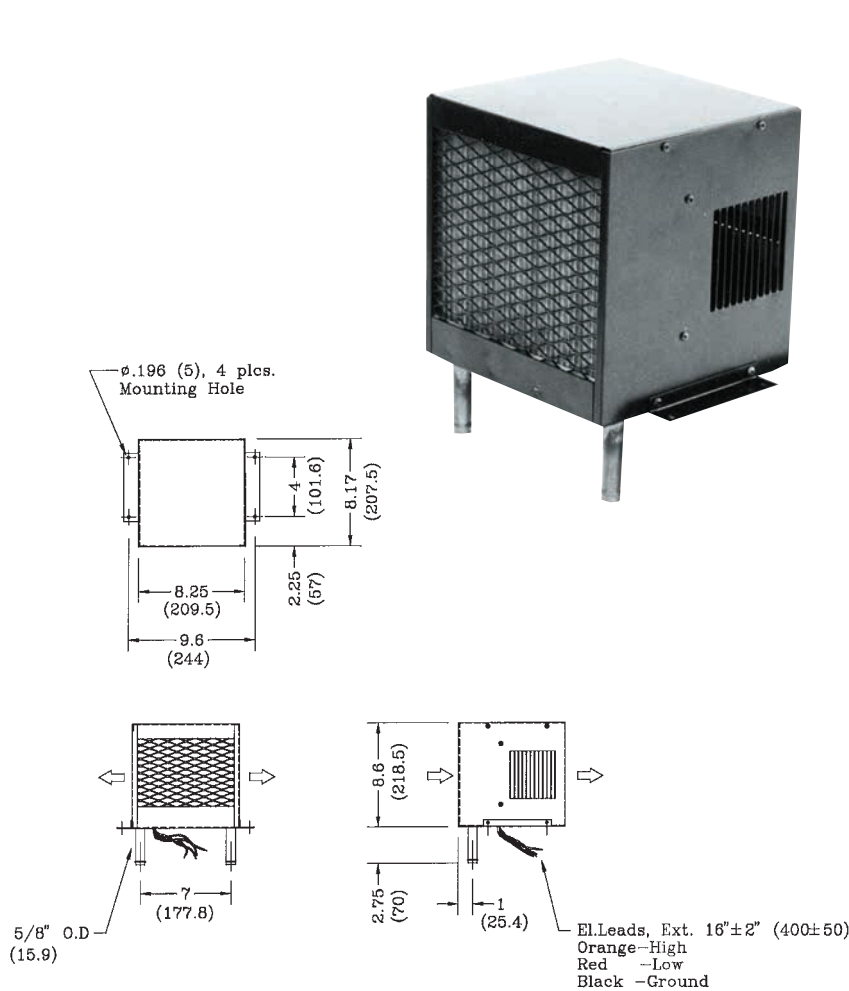

Part Descriptions: Specifications

Part No.		No.	Part No.	Description
12-2251	Heater 12V	1	24-0167	Casing
12-2252	Heater 24V	2	24-0142	Cover
		3	24-0161	Cover
		4	24-0133	Mounting Bracket
		5	24-0141	Venturi
		6	24-0110	Motor Bracket
		7	24-0171	Coil Protector
		8	25-0105	Motor 12V
			25-0107	Motor 24V
		9	25-0023	Fan
		10	22-0033	Heater Coil
		11	28-0014	Grommet

Features

The compact design of the 222 is ideal for dash or under seat mounting.

Fan Heater Model 226

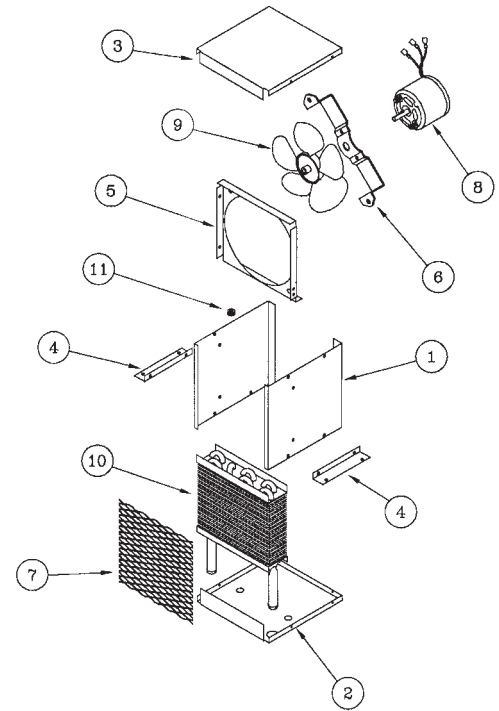
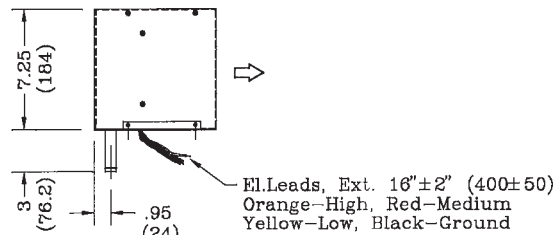
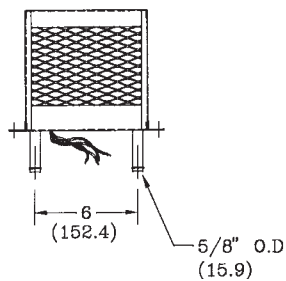
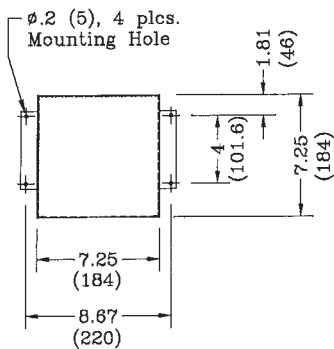

Part Descriptions: Specifications

Part No.	Description	No.	Part No.	Description
12-2611	Heater 12V	1	24-0173	Side Plate
		2	24-0136	Cover
		3	24-0160	Cover
		4	24-0133	Mounting Bracket
		5	24-0138	Venturi
		6	24-0110	Motor Bracket
		7	24-0172	Coil Protector
		8	25-0105	Motor 12V
		9	25-0023	Fan
		10	22-0052	Heater Coil
		11	28-0014	Grommet

Specifications

Heating	-13500 Btu/hr (3960 W)
Air Flow	-185 CFM (315 m ³ /h)
Current	-5.8 Amps
Weight	-4.5 lbs. (2 kg)
2-Speed motor.	

Features

The 226 was designed to offer flexible mounting and deliver air directly out front of the heater.

Fan Heater Model 238

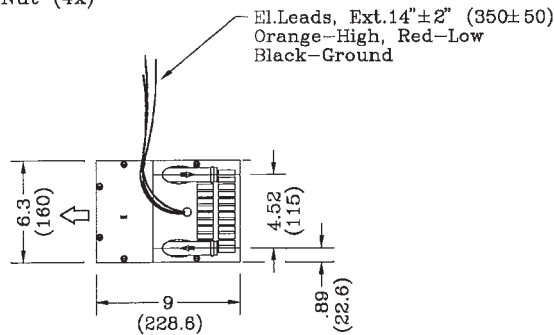
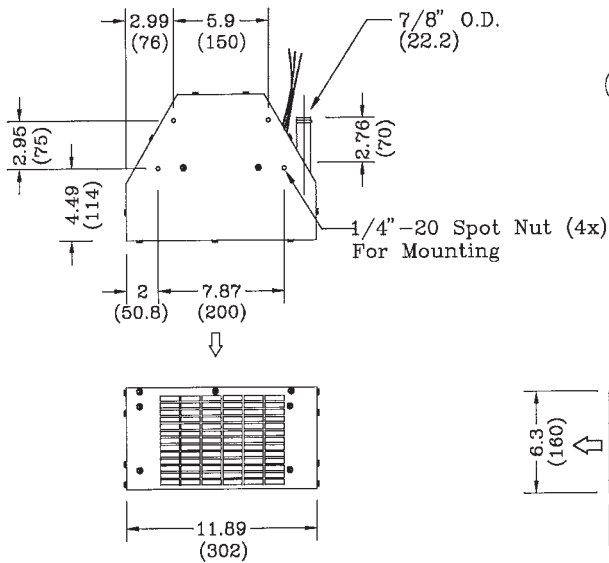
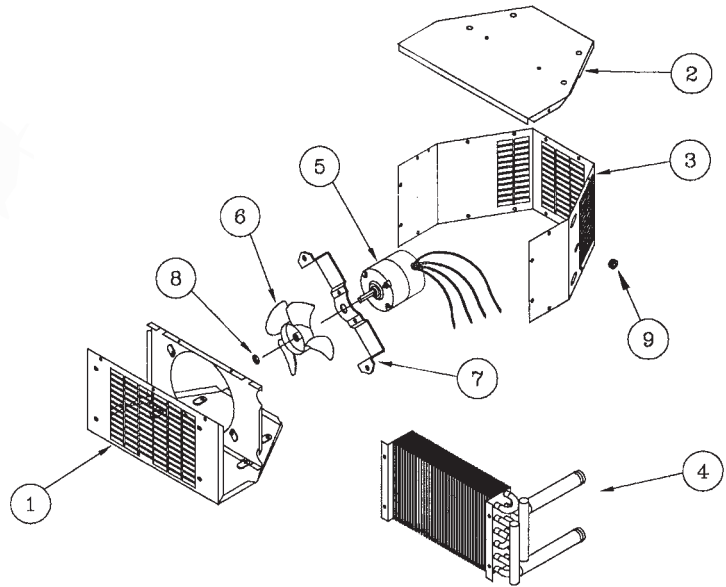
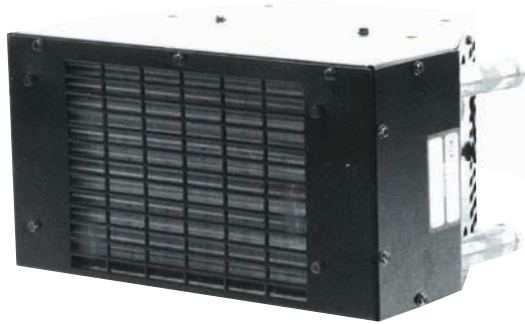

Part Descriptions: Specifications

Part No.		No.	Part No.	Description
12-3811	Heater 12V	1	24-0147	Casing
12-3812	Heater 24V	2	24-0148	Top Cover
		3	24-0149	Side Cover
		4	22-0110	Heater Coil
		5	25-0105	Motor 12V
			25-0107	Motor 24V
		6	25-0041	Fan
		7	25-0110	Motor Bracket
		8	29-0039	Retaining Ring
		9	28-0014	Grommet

Specifications

Heating	-22500 Btu/hr (6600 W)
Air Flow	-250 CFM (425 m ³ /h)
Current	-4 Amps/12V -2 Amps/24V
Weight	-11.5 lbs. (5.2 kg)
2-Speed motor.	

Features

The 238 is ideal for underseat mounting. Air is disbursed to the front of the unit.

Fan Heater Model 239

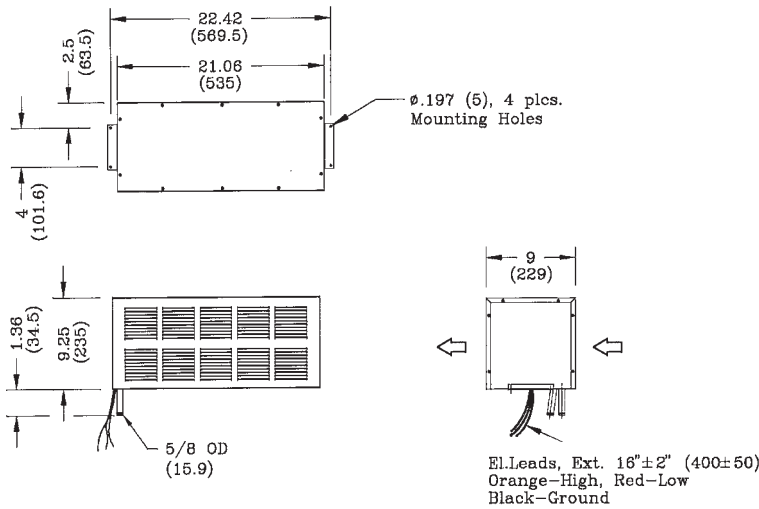
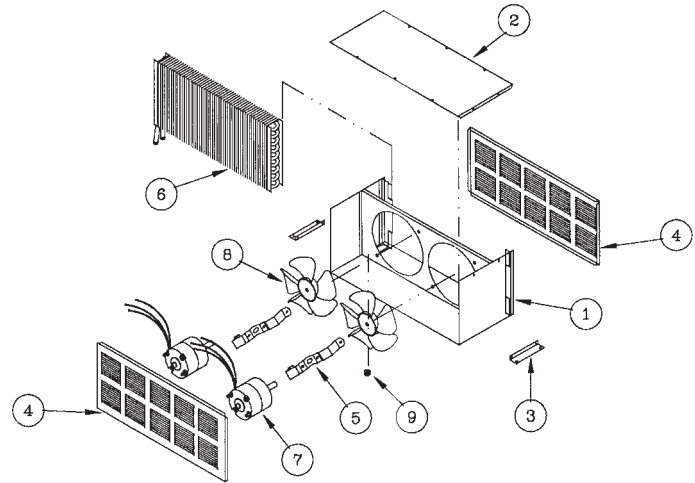

Part Descriptions: Specifications

Part No.		No.	Part No.	Description
12-3903	Heater 12V	1	24-0356	Casing
12-3904	Heater 24V	2	24-0357	Cover
		3	24-0133	Mounting Bracket
		4	24-0358	Grill
		5	24-0223	Motor Bracket
		6	22-0030	Heater Coil
		7	25-0344	Motor 12V
			25-0107	Motor 24V
		8	25-0121	Fan (8" C.W.)
		9	28-0004	Grommet

Specifications

Heating	- 64000 Btu/hr (18760 W)
Air Flow	- 800 CFM (1360 m ³ /h)
Current	- 13 Amps/12V
	- 6.5 Amps/24V
Weight	- 25 lbs. (11.3 kg)
2-Speed motor.	

Features

The 239 is our largest capacity fan heater - ideal for buses and other large capacity requirements.

Fan Heater Model 245

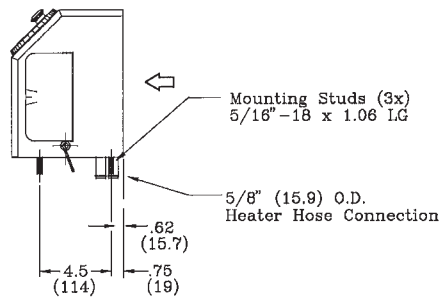
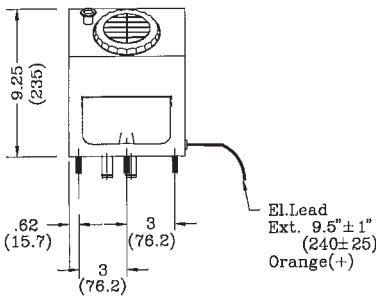
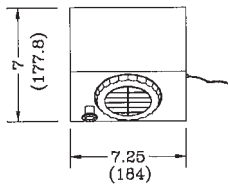
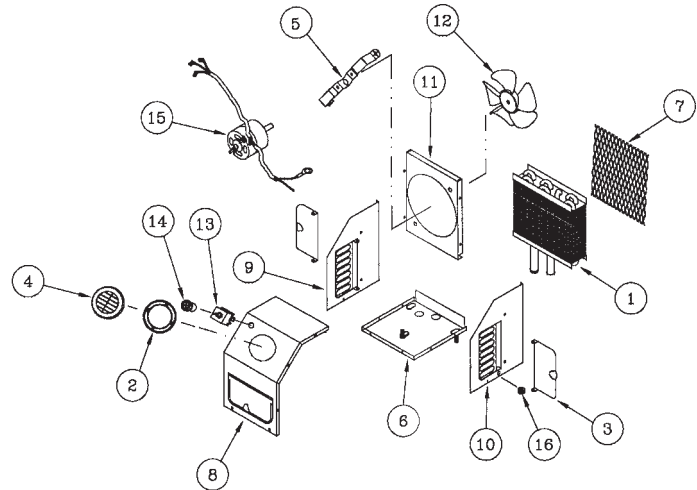
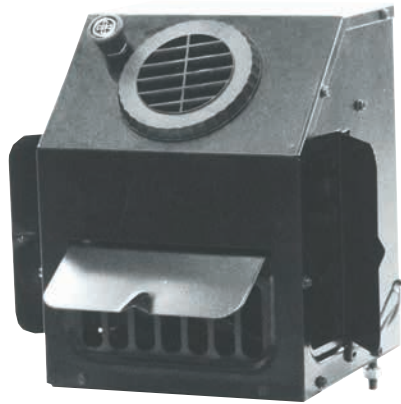

Part Descriptions: Specifications

Part No.	No.	Part No.	Description	No.	Part No.	Description	
12-4503	Heater 12V	1	22-0140	Heater Coil	10	24-0893	Side (R)
12-4504	Heater 24V	2	23-0048	Adapter	11	24-0894	Venturi
		3	23-0009	Door	12	25-0023	Fan (6.6" C.C.W.)
		4	23-0045	Louver	13	25-0029	Switch
		5	24-0110	Motor Bracket	14	25-0067	Knob
		6	24-0175	Base	15	25-0105	Motor 12V
		7	24-0890	Coil Protector		25-0107	Motor 24V
		8	24-0891	Cover	16	28-0014	Grommet
		9	24-0892	Side (L)			

Specifications
 Heating -20000 Btu/hr (5860 W)
 Air Flow -265 CFM (450 m³/h)
 Current -5.8 Amps/12V
 -2.9 Amps/24V
 Weight -8.5 lbs. (3.8 kg)
 2-Speed motor.
 Heater is internally grounded.

Features

The 245 offers the ability to control fan speed with a control on the box. Ideal for auxiliary heaters or small cab applications.

Fan Heater Model 290E (Europe only)

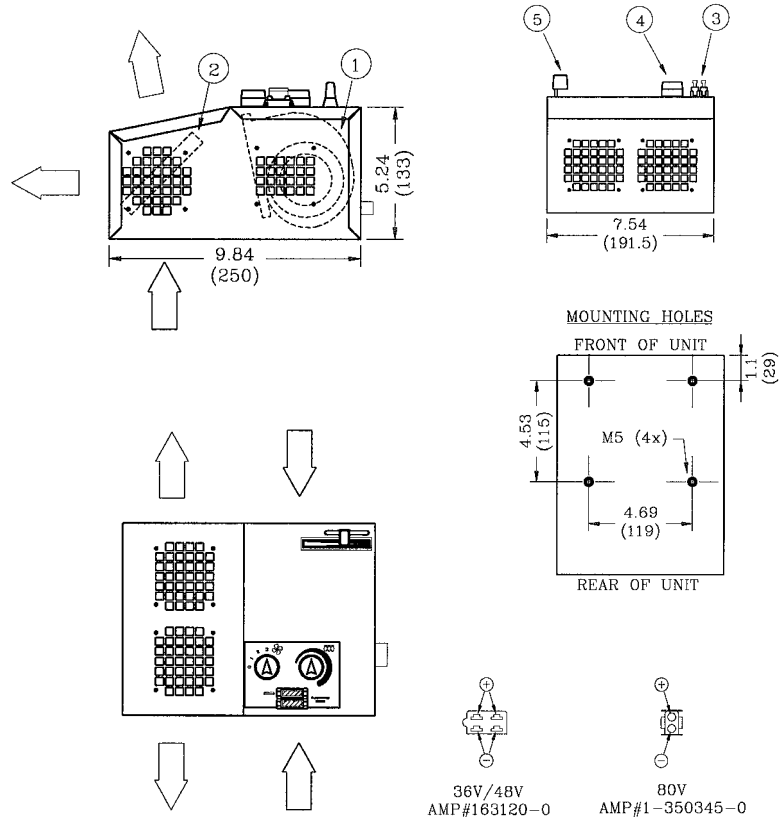

Part Descriptions: Specifications

Part No.	No.	Part No.	Description	No.	Part No.	Description
12-9080		Heater 36V		1	15-0290	Blower 24V
12-9048		Heater 48V		2	25-1171	Heater Element 80V
12-9036		Heater 80V		2	25-1170	Heater Element 48V
				2	25-1169	Heater Element 36V
				3	25-1172	Fuse 30/A 80V At 80V
				3	25-1173	Fuse 20/A/80V
				3	25-1174	Fuse 20A/32V At 36V
				4	25-1175	Knob
				5	26-0712	Lever
				6	25-1181	Resistor 36V (3.3Ω)
				6	25-1184	Resistor 48V (6.8Ω)
				6	25-1182	Resistor 80V (15Ω)
				7	25-1185	Resistor 36V (2.2Ω)
				7	25-1183	Resistor 48V (4.7Ω)
				7	25-1179	Resistor 80V (10Ω)
				8	25-1180	Thermostat
				9	25-1178	Relay 24V

Specifications	
Heating	36V - 1000 Btu/hr (292.87W) 48V - 1600 Btu/hr (468.59W) 80V - 2000 Btu/hr (585.74W)
Air Flow	82.4 CFM (140 m ³ /h)
Current	36V - 28A 48V - 33A 80V - 25A
Weight	8.8 lbs. (4kg)

Items 6 through 9 are not shown.	
Part	MCC P/N
Casing	11.058.00.001
Cover (80V)	11.058.00.002
Cover (36/48V)	11.058.00.009
Decal	20.400.00.244

Fan Heater **Model 290N** (North America only)

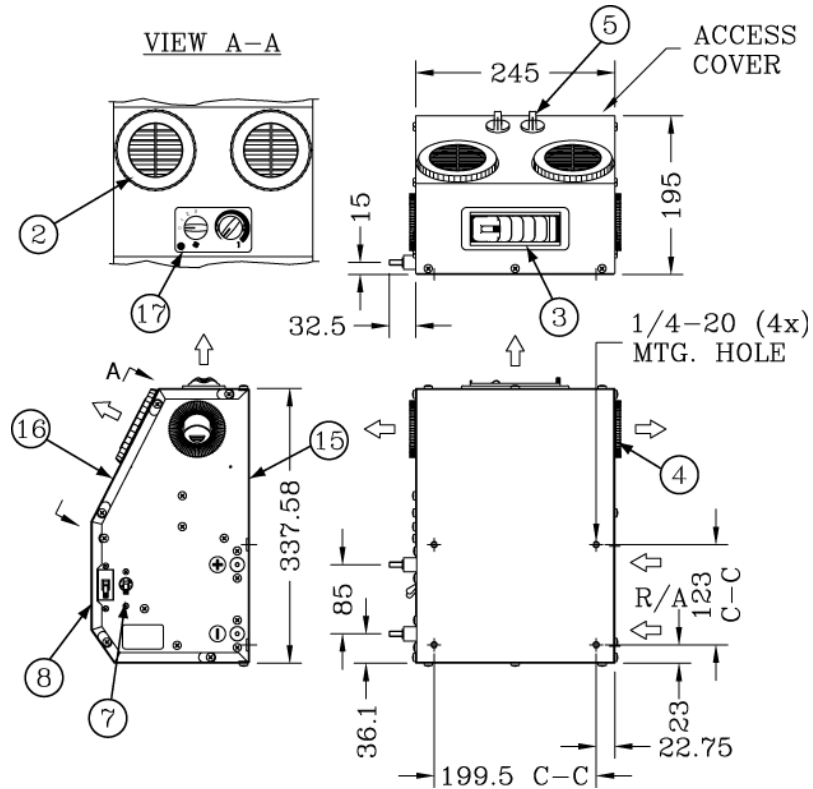

Part Descriptions: Specifications

Specifications	No.	Part No.	Description	No.	Part No.	Description
Heating		3	23-0145 Louver	11	25-1204	Contactor
		4	23-0171 Louver	12	25-1373	Resistor 10Ω (12-9038)
Air flow		5	25-0435 Knob	13	25-1760	Resistor 4Ω (12-9050)
		6	25-1160 Heater Element 48V	14	25-1761	Resistor 2.5Ω (12-9038/12-9050)
Current		6	25-1169 Heater Element 36V	15	24-4796	Casing Stainless Steel
Weight		7	25-1372 Circuit Breaker 8A/80V	16	24-4797	Cover Stainless Steel
		8	25-1481 Circuit Breaker 50A/80V	17	28-0722	Overlay
		8	25-2459 Circuit Breaker 60A/80V			Items 1,6,10 to 14 are not shown

Blower Heater Model 202

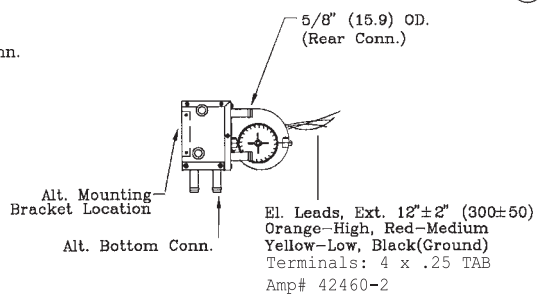
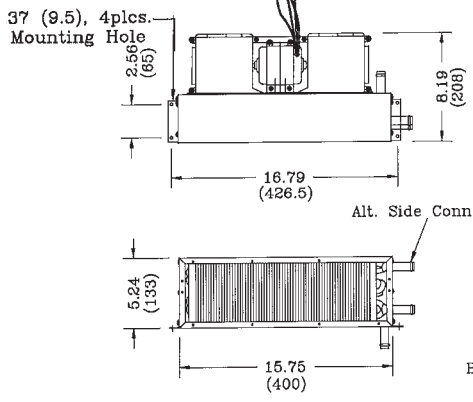
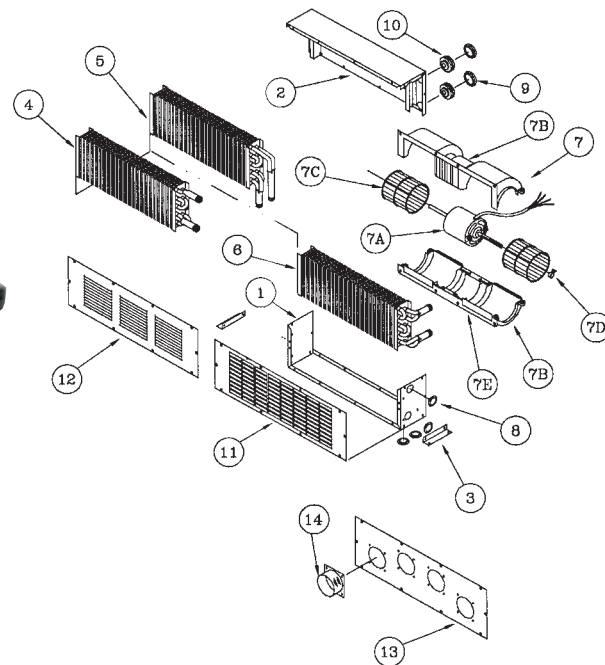

Part Descriptions: Specifications

Part No.	No.	Part No.	Description	No.	Part No.	Description
12-0203		1	Heater 12V - Rear Conn.	7D	25-0022	Clip
12-0213		2	Heater 12V - Side Conn.	7E	25-0020	Motor Tape
12-0204		3	Heater 24V - Rear Conn.	8	28-0010	Snap-in Plug
12-0214		4	Heater 24V - Side Conn.	9	28-0013	Snap-in Plug
12-0293		5	Heater 12V - Bottom Conn.	10	28-0005	Grommet (Rear Conn.)
		6	Heater Coil (Rear Conn.)	11	24-0060	Grill
		7	Blower Assy. 12V	12	24-0045	Grill
		7A	Blower Assy. 24V	13	24-0066	Front (4 x 2\"/>

Specifications

Heating	- 24700 Btu/hr (7240 W)
Air Flow	- 295 CFM (500 m ³ /h)
Current	- 12 Amps/12V - 6 Amps/24V
Weight	- 9 lbs. (4 kg)
3-Speed motor.	

Features

The 202 offers flexible installation options to fit a wide range of applications. Can be ducted for defrost capabilities. Also available with an oil coil.

Items 11-14 are optional and have to be ordered separately.

Blower Heater Model 202 Oil

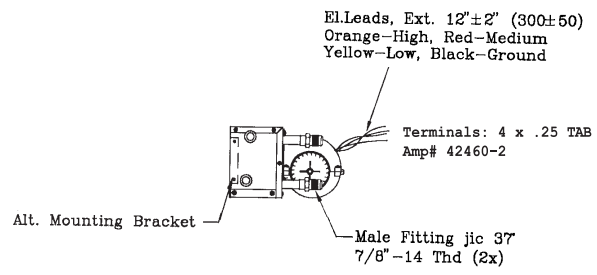
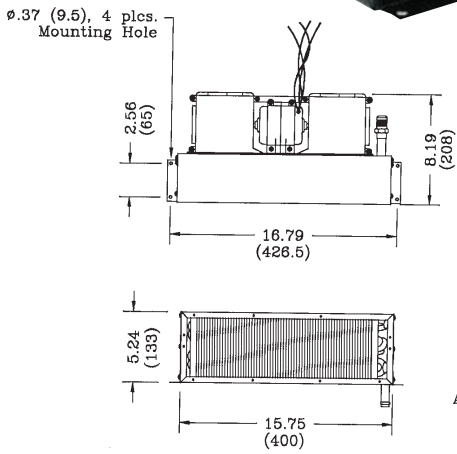
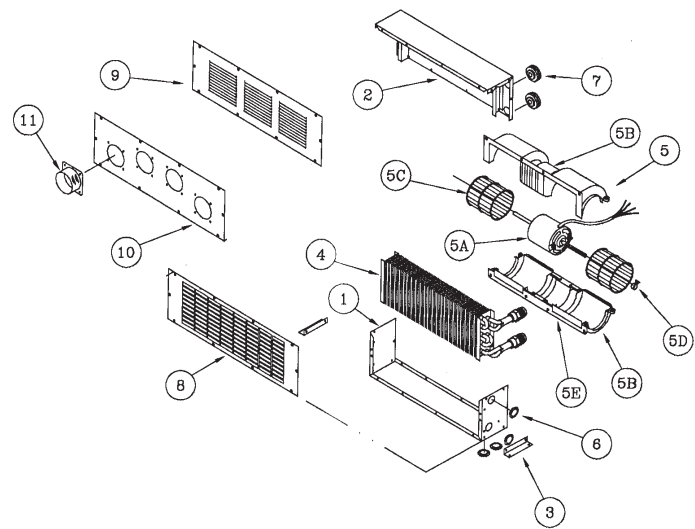

Part Descriptions: Specifications

Part No.	No.	Part No.	Description	No.	Part No.	Description
12-0253		1	24-0009 Casing	5D	25-0022	Clip
12-0254		2	24-0008 Cover	5E	25-0020	Motor Tape
		3	24-0012 Mounting Bracket	6	28-0010	Snap-in Plug
		4	22-0282 Heater Coil (Oil)	7	28-0005	Grommet
		5	15-0503 Blower Assy. 12V	8	24-0060	Grill
			15-0504 Blower Assy. 24V	9	24-0045	Grill
		5A	25-0070 Motor 12V	10	24-0066	Front (4 x 2" HA)
			25-0075 Motor 24V		24-0067	Front (4 x 2 1/2" HA)
		5B	25-0017 Blower Housing	11	23-0110	Hose Adapter 2"
		5C	25-0021 Blower Wheel		23-0125	Hose Adapter 2 1/2"

Specifications

Heating - 14500 Btu/hr (4250 W)
 Air Flow - 295 CFM (500 m3/h)
 Current - 12 Amps/12V
 - 6 Amps/24V
 Weight - 9 lbs. (4 kg)
 3-Speed motor.

Items 8-11 are optional and have to be ordered separately.

Features

The 202 offers flexible installation options to fit a wide range of applications. Can be ducted for defrost capabilities.

Blower Heater Model 205

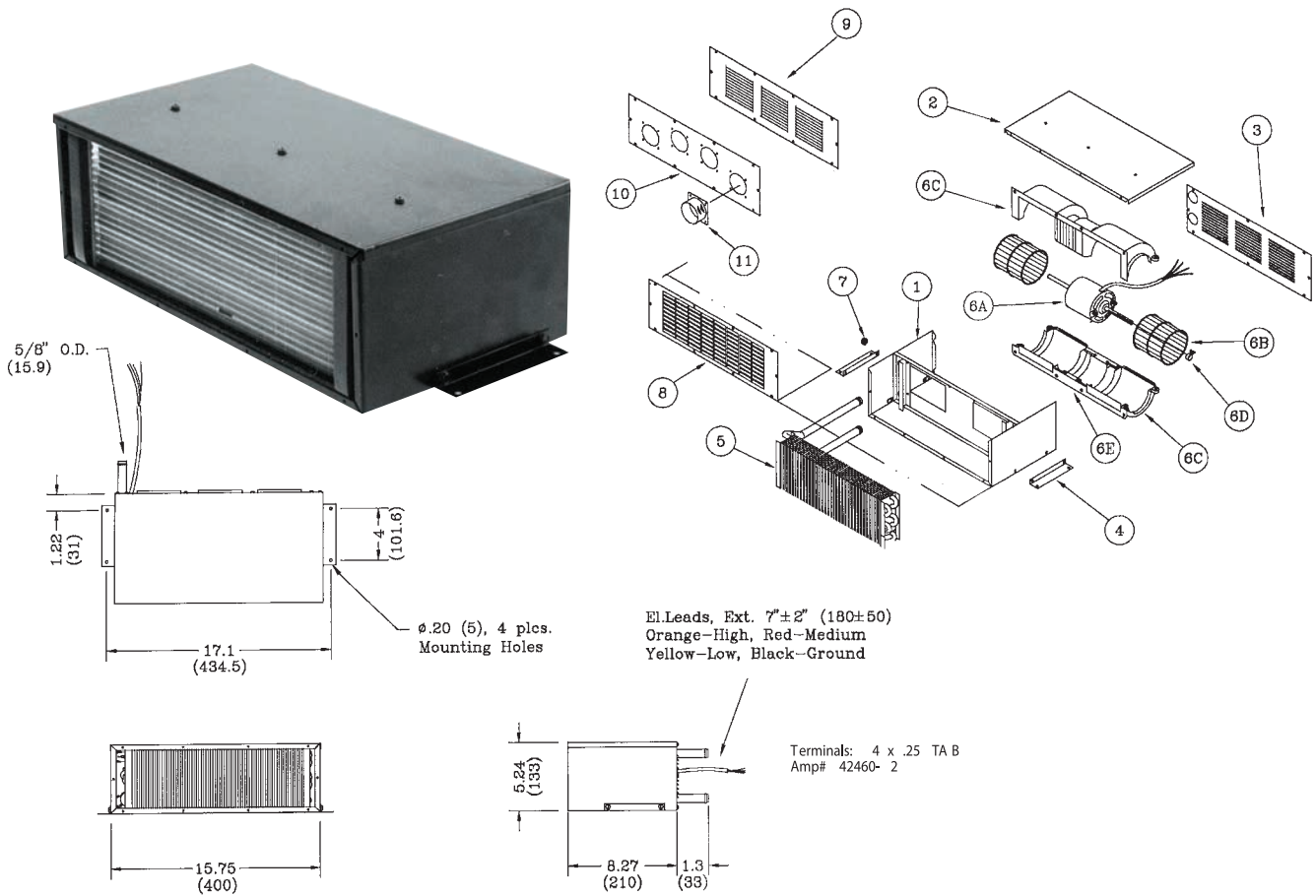

Part Descriptions: Specifications

Part No.	No.	Part No.	Description	No.	Part No.	Description
12-0503	1	24-0225	Casing	7	28-0014	Grommet
12-0504	2	24-0226	Cover	8	24-0060	Grill
	3	24-0199	Grill	9	24-0045	Grill
	4	24-0133	Mounting Bracket	10	24-0066	Front (4 x 2" HA)
	5	22-0060	Heater Coil		24-0067	Front (4 x 2 1/2" HA)
	6	15-0503	Blower Assy. 12V	11	23-0110	Hose Adapter 2"
		15-0504	Blower Assy. 24V		23-0125	Hose Adapter 2 1/2"
	6A	25-0070	Motor 12V			
		25-0075	Motor 24V			
	6B	25-0021	Blower Wheel			
	6C	25-0017	Blower Housing			
	6D	25-0022	Clip			
	6E	25-0020	Motor Tape			

Items 8-11 are optional and have to be ordered separately.

Features

A more heavy duty option than the 202. The 205 offers the same installation flexibility. Also available with an oil coil.

Blower Heater Model 205 Oil

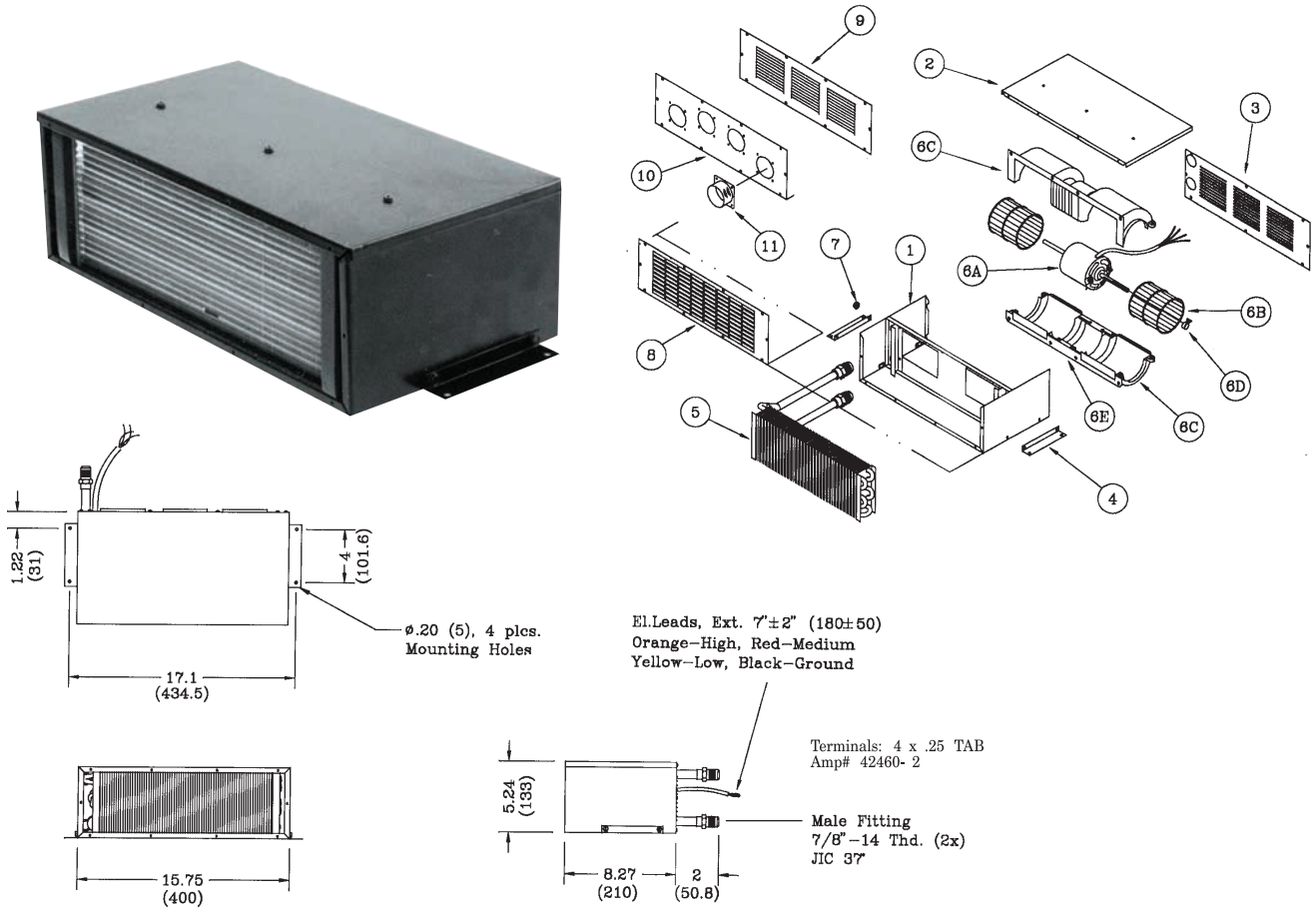

Part Descriptions: Specifications

Part No.	No.	Part No.	Description	No.	Part No.	Description	
12-0553		12-0553	Heater 12V	7	28-0014	Grommet	
12-0554		12-0554	Heater 24V	8	24-0060	Grill	
		1	24-0225	Casing	9	24-0045	Grill
		2	24-0226	Cover	10	24-0066	Front (4 x 2" HA)
		3	24-0199	Grill		24-0067	Front (4 x 2 1/2" HA)
		4	24-0133	Mounting Bracket	11	23-0110	Hose Adapter 2"
		5	22-0283	Heater Coil		23-0125	Hose Adapter 2 1/2'
		6	15-0503	Blower Assy. 12V			
			15-0504	Blower Assy. 24V			
		6A	25-0070	Motor 12V			
			25-0075	Motor 24V			
		6B	25-0021	Blower Wheel			
		6C	25-0017	Blower Housing			
		6D	25-0022	Clip			
		6E	25-0020	Motor Tape			

Items 8-11 are optional and have to be ordered separately.

Features

A more heavy duty option than the 202. The 205 offers the same installation flexibility.

Blower Heater Model 212

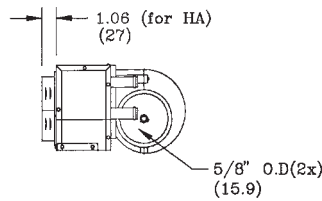
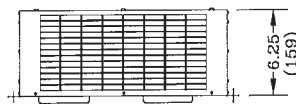
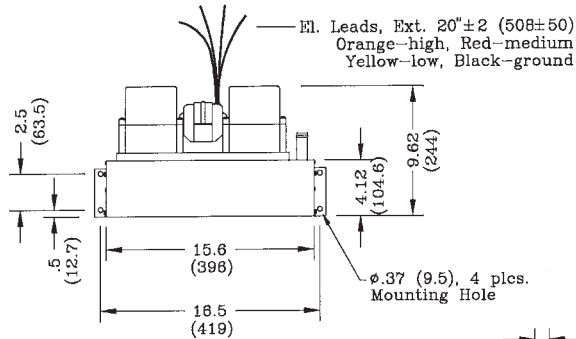
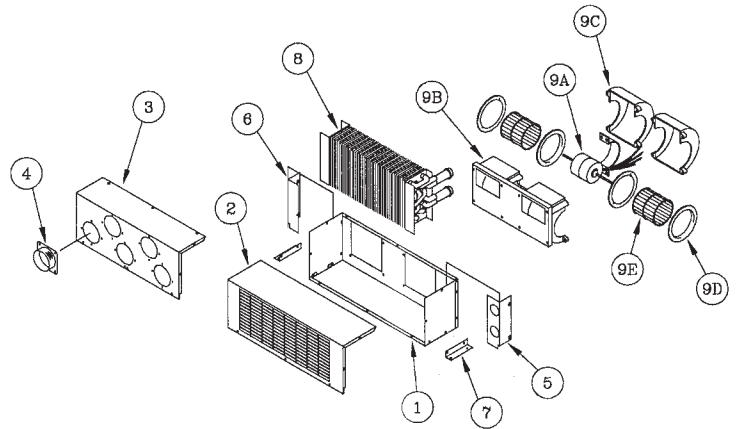

Part Descriptions: Specifications

Part No.	No.	Part No.	Description	No.	Part No.	Description
12-1203	1	24-0055	Casing	9	15-1513	Blower Assy. 12V
12-1204	2	24-0056	Cover		15-1514	Blower Assy. 24V
12-1223	3	24-1011	Cover (5 HA's)	9A	25-0053	Motor 12V, 3-Speed
12-1224	4	23-0125	Hose Adapter 2 1/2"		25-0076	Motor 24V, 3-Speed
	5	24-0057	Coil Bracket	9B	25-0048	Blower Housing
	6	24-0058	Coil Bracket	9C	25-0348	Housing Top
	7	24-0012	Mounting Bracket	9D	25-0060	Venturi
	8	22-0090	Heater Coil	9E	25-0200	Blower Wheel
					25-0022	Clip (B.W.)

Specifications

Heating	-36000 Btu/hr (10550 W)
Air Flow	-400 CFM (680 m ³ /h)
Current	-14 Amps/12V
	-8 Amps/24V
Weight	-12 lbs. (5.5 kg)
3-Speed motor.	

Features

A higher capacity heater than the 202 and 205, the 212 equipped with hose adapters offers installation flexibility for defrosting and cab ducting requirements.

Blower Heater Model 212 Oil

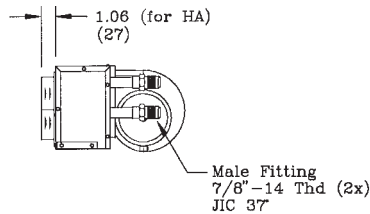
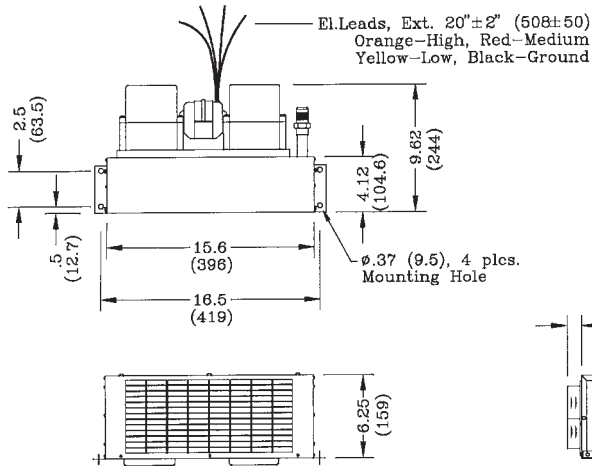
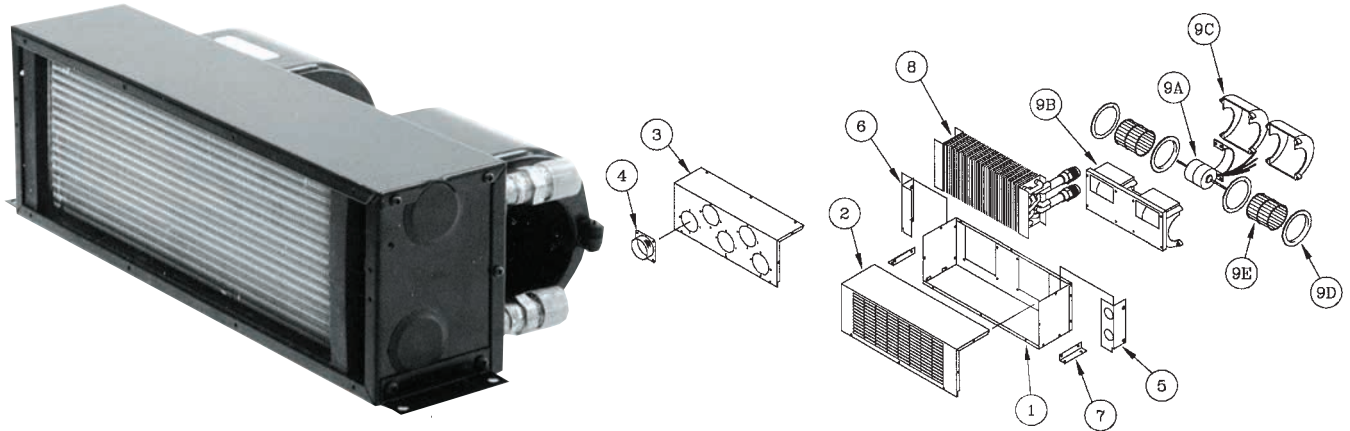

Part Descriptions: Specifications

Part No.	No.	Part No.	Description	No.	Part No.	Description
12-1251	1	24-0055	Casing	9	15-1513	Blower Assy. 12V
12-1252	2	24-0056	Cover		15-1514	Blower Assy. 24V
12-1255	3	24-1011	Cover (5 HA's)	9A	25-0053	Motor 12V, 3-Speed
12-1256	4	23-0125	Hose Adapter 2 1/2"		25-0076	Motor 24V, 3-Speed
	5	24-0057	Coil Bracket	9B	25-0048	Blower Housing
	6	24-0058	Coil Bracket	9C	25-0348	Housing Top
	7	24-0012	Mounting Bracket	9D	25-0060	Venturi
	8	22-0284	Heater Coil (Oil)	9E	25-0200	Blower Wheel
					25-0022	Clip (B.W.)

Specifications

Heating	-36000 Btu/hr (10550 W)
Air Flow	-400 CFM (680 m ³ /h)
Current	-14 Amps/12V -8 Amps/24V
Weight	-12 lbs. (5.5 kg)
3-Speed motor.	

Features

A higher capacity heater than the 202 and 205, the 212 offers installation flexibility for defrosting and cab ducting requirements.

Blower Heater Model 212 Marine

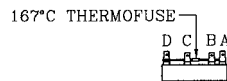
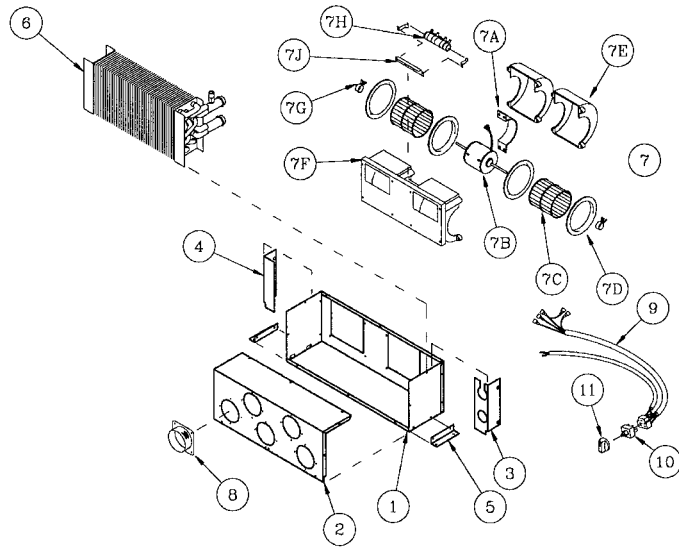
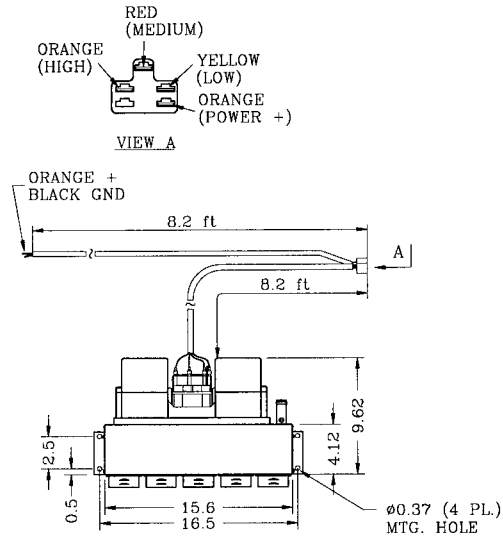

DETAIL OF RESISTOR

- A - TO MOTOR (ORANGE)
- B - LOW SPEED
- C - MED. SPEED
- D - HIGH SPEED

Important! Motor is of a non-explosion proof design. The heater must be installed in areas where flammable liquids and vapors are not present.

Part Descriptions: Specifications

Part No.	No.	Part No.	Description	No.	Part No.	Description	
12-1239	Heater 12V	1	24-3937	Casing	7D	25-0060	Venturi
		2	24-3938	Cover	7E	25-0348	Housing Top
		3	24-3939	Coil Bracket	7F	25-0048	Blower Housing
		4	24-3940	Coil Bracket	7G	28-0022	Clip
		5	24-3945	Mounting Bracket	7H	25-0601	Resistor 12V w/Bkt
		6	22-0520	Heater Coil	7J	29-0130	Resistor Bracket
		7	15-1561	Blower Assy. 12V	8	23-0125	Hose Adapter 2 1/2"
		7A	25-0861	Motor Mount	9	25-1126	Wiring Harness
		7B	25-0655	Motor 12V	10	25-0044	Switch 25 Amp
		7C	25-0200	Blower Wheel	11	25-0067	Knob

Specifications

Heating - 40000 Btu/hr (11700 W)
 Air Flow - 500 CFM (850 m³/h)
 Current - 22 Amps/12V
 Weight - 15 lbs. (6.8 kg)
 PM Motor 3-Speed motor.
 All Hardware Stainless Steel

Features

This powerful version of the popular #212 family of heaters is specifically designed for the corrosive ocean environment. Coil is made of copper with stainless steel (SS) end plates. Hardware and casing are made of SS as well. Engineering plastics are used for hose adapters and blower. Details of the blower can be found in the blower section. Hose adapters make the heater suitable for ducting to windshields etc. Switch for 3 speed operation, wiring harness and knob are included.

Low Amp Heater Model 234

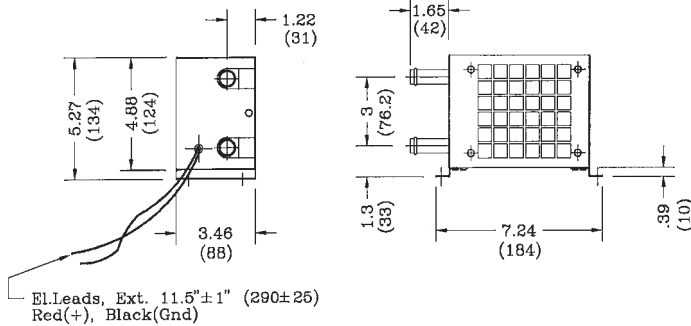
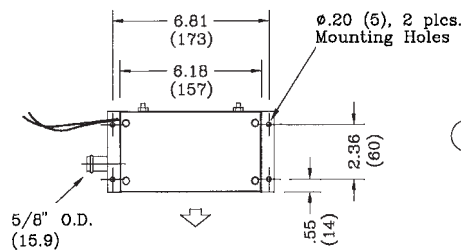
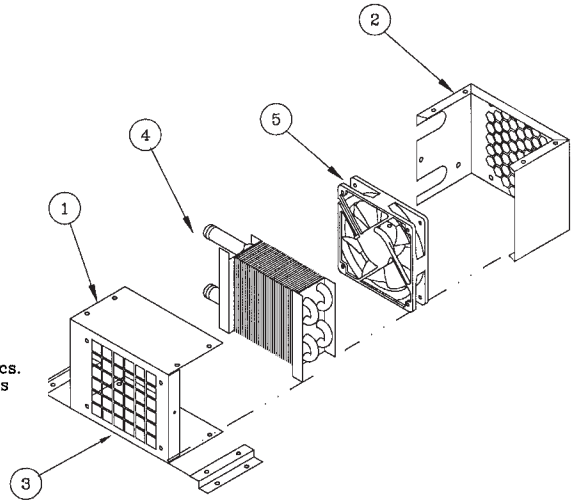

Part Descriptions: Specifications

Part No.	No.	Part No.	Description
12-3421	1	24-1105	Casing (Front)
12-3422	2	24-1106	Casing (Rear)
	3	24-1107	Mounting Bracket
	4	24-0041	Heater Coil
	5	25-0172	Fan 12V
		25-0244	Fan 24V

Specifications

Heating - 32000 Btu/hr (9380 W)
 Air Flow - 350 CFM (595 m³/h)
 Current - 12 Amps/12V
 - 6 Amps/24V
 Weight - 25.5 lbs. (11.5 kg)
 2-Speed motor.

Features

The low amp current of the 234HD allows for mounting in applications such as motor homes, where an auxiliary heater is required.

Low Amp Heater Model 236

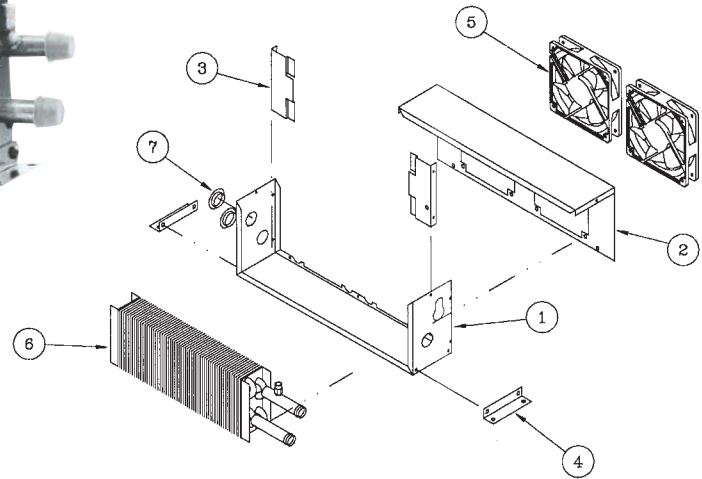
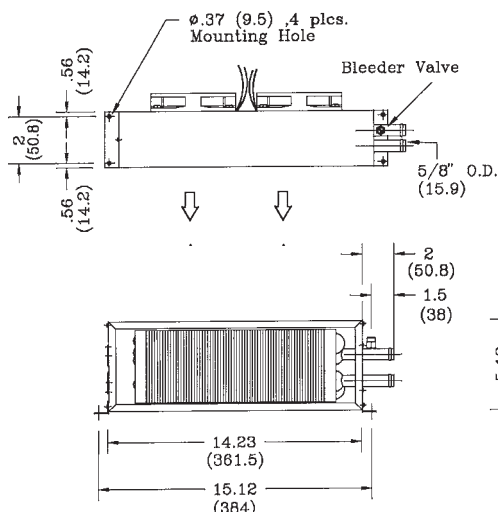
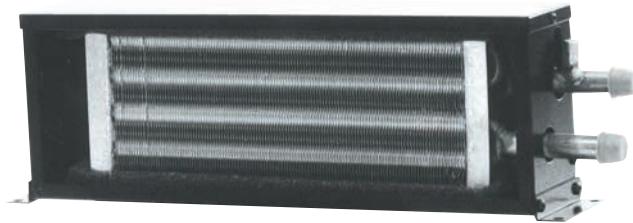

Part Descriptions: Specifications

Part No.		No.	Part No.	Description
12-3601	Heater 12V	1	24-0369	Casing
12-3602	Heater 24V	2	24-0370	Cover
		3	24-0380	Coil Bracket
		4	24-0012	Mounting Bracket
		5	25-0172	Fan 12V
			25-0244	Fan 24V
		6	22-0083	Heater Coil
		7	28-0010	Snap-in Plug

Specifications

Heating	-8700 Btu/hr (2550 W)
Air Flow	-130 CFM (220 m ³ /h)
Current	-0.7 Amps/12V
	-0.35 Amps/24V
Weight	-5 lbs. (2.3 kg)
1-Speed motor.	

Features

A larger capacity heater than the 234HD, the 236 offers the capacity to handle larger low amp heater requirements.

Low Amp Heater Model 247

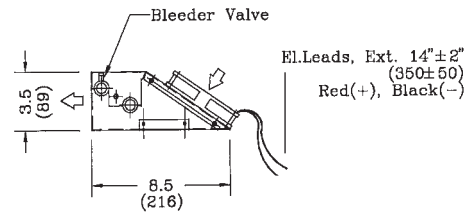
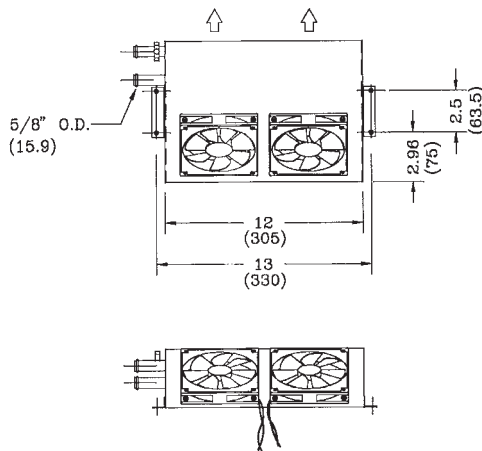
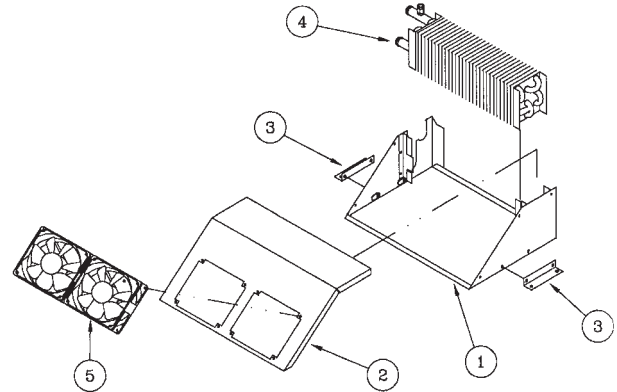
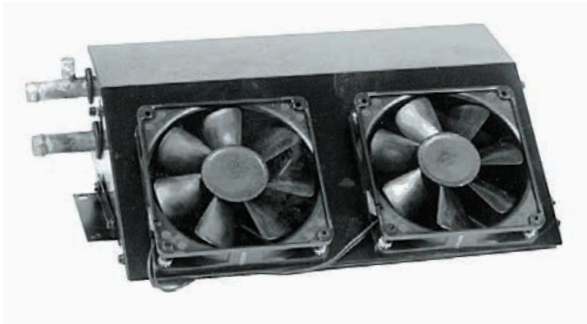

Part Descriptions: Specifications

Part No.		No.	Part No.	Description
12-4701	Heater 12V	1	24-1114	Casing
12-4702	Heater 24V	2	24-1115	Cover
		3	24-0012	Mounting Bracket
		4	22-0171	Heater Coil
		5	25-0172	Fan 12V
			25-0144	Fan 24V

Specifications

Heating	-8700 Btu/hr (2550 W)
Air Flow	-130 CFM (220 m ³ /h)
Current	-0.70 Amps/12V -0.35 Amps/24V
Weight	-6.1 lbs. (2.8 kg)
1-Speed motor.	

Features

The 247 is another option for low amp heater requirements.

Low Amp Heater Model 249

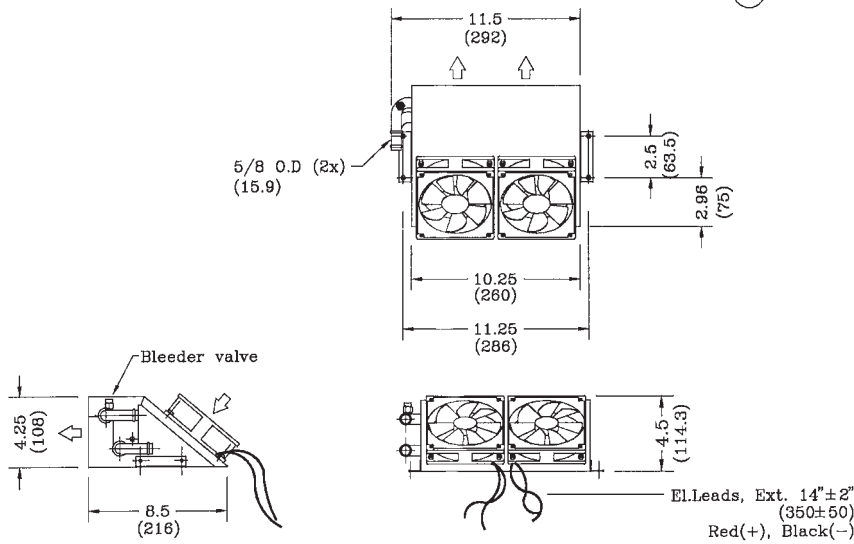
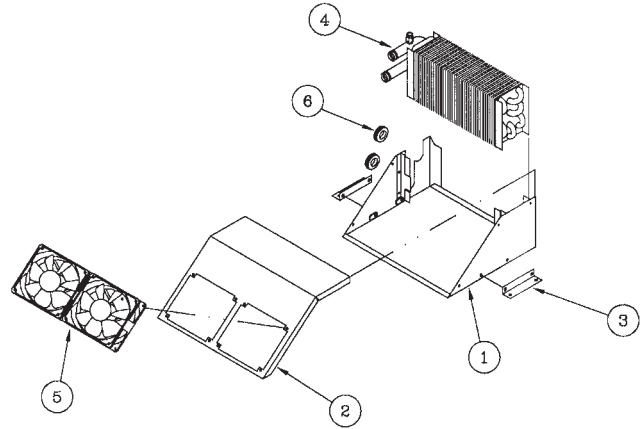

Part Descriptions: Specifications

Part No.	Description	No.	Part No.	Description
12-4901	Heater 12V	1	24-1189	Casing
		2	24-1190	Cover
		3	24-0012	Mounting Bracket
		4	22-0203	Heater Coil
		5	25-0447	Fan 12V
		6	28-0009	Grommet

Specifications	
Heating	-10000 Btu/hr (2930 W)
Air Flow	-160 CFM (270 m ³ /h)
Current	- 1.0 Amps/12V
Weight	-7.5 lbs. (3.4 kg)
1-Speed motor.	

Features

The 249 offers similar mounting and installation to the 247, in a larger capacity package.