

# UWE Electric parking heater

## - perfect heating solution for parked buses

### SUMMARY

- Electric parking heater to connect to the vehicle's water heating system
- Designed for minibuses and buses
- Range from 2kW-9.8 kW

### FEATURES

- Reliable and tried in a robust design
- Most models offers possibility to switch between two power settings

**T**he UWE Parking Heater is a reliable, tried and tested immersion heater for heating parked buses fitted with a waterborne heating system.

The immersion heater, which is available in power settings from 2 kW – 9.8 kW, is simply connected to the existing heating system and blends into the interior thanks to its discreet, compact design. The UWE Parking Heater is simply connected to the mains by an instant coupling, which makes replacing it much easier. A hose connection for water can be placed on either the right or left of the outlet. In most models there is the facility to switch manually between full and half power in one easy action, which can be useful if you have problems with the fuses.

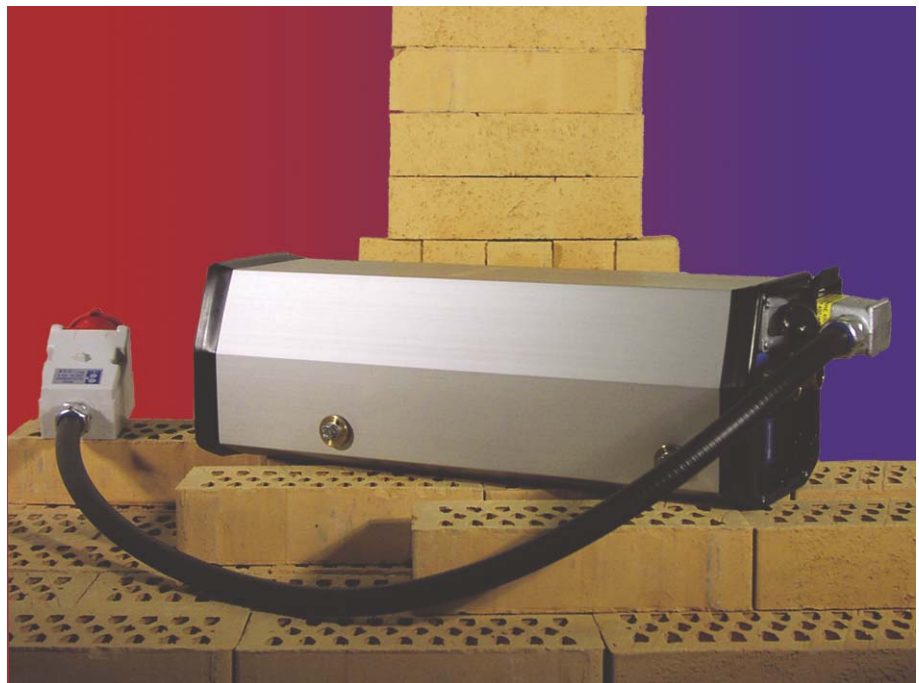

**UWE**®

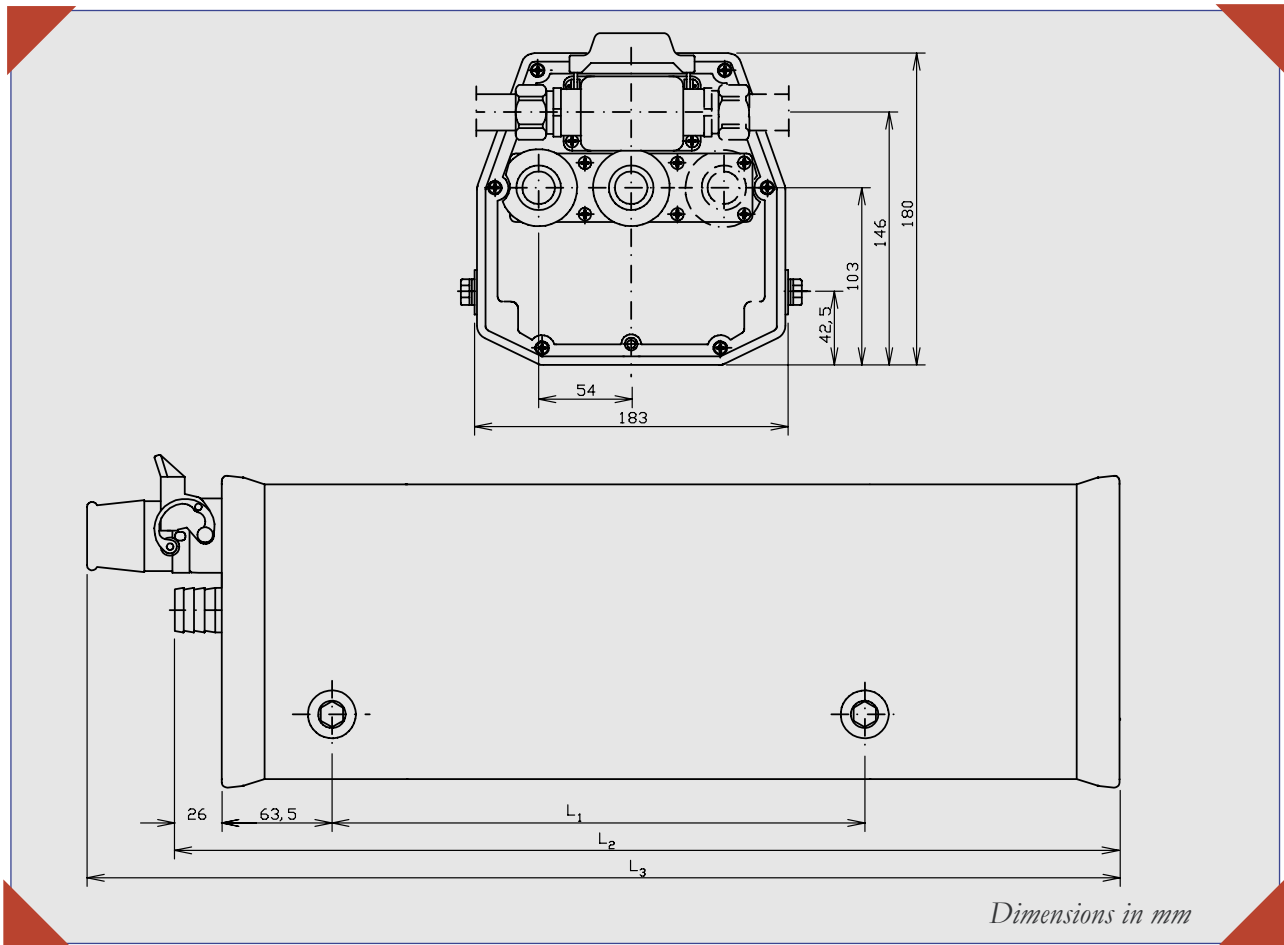

## Technical Data

Art. no.	17076	17104	17077	17078	17080	17079
Power	9800 W	9800 W (4900W)*	7600 W	6000 W (3000W)*	6000 W (3000W)*	3000 W (2000W)*
Voltage	400V 3-phase	400V 3-phase	400V 3-phase	400V 3-phase	230V 3-phase	230V 1-phase
Power cons.	15 A	15 A (7,5)	11A	10A (5A)	15A (8A)	14A (10A)
Water conn.	25 mm	25 mm	25 mm	25 mm	25 mm	25 mm
Weight, kg	12.5	12.5	12.5	10.5	10.5	9
Length L <sub>1</sub>	311	311	311	211	211	111
Length L <sub>2</sub>	550	550	550	450	450	350
Length L <sub>3</sub>	600	600	600	500	500	400

\* figures in brackets relate to alternative power setting (changed using the switch on one end).

Adv017E01en

UWE Verken AB, Box 262, S-601 04 Norrköping, Sweden  
 Tel +46 11 248800, Fax +46 11 124704  
 www.uwe.se, email:info@uwe.se  
 Member of MCC Group - Certified ISO 9001



Specifications subject to change without notice. UWE and MCC are registered trademarks.