

### Description

#### Range of application

The Defroster Global is especially designed to be used in large vehicles to serve as a defroster with air condition as an option.

Thanks to its module based construction, most of the defroster components can be flipped and/or turned to suit your demands. For instance it is possible to change from right to left water connection; air filter before or after the heat exchanger; sucking or pressing fan - all these changes can be executed in a couple of minutes.

Another great advantage with the Defroster Global is its very small dimensions (see page 3).

#### Design

The defroster unit includes two main modules: Air intake module (Option: AC), and the fan- and heat module.

#### Air intake module

The air intake module consists in the basic version of an aluminium box with an air intake. It can also be equipped with an air intake flap with flap motor, to enable regulation between fresh and recirculated air. The air intake module can also be equipped with an evaporator to enable air conditioning. See figure below.

#### Fan- and heat module

The fundamental module of the Defroster Global is the fan- and heat module which houses a double radial fan, heater core and an air filter. This module is connected together with the air intake module. See figure below.

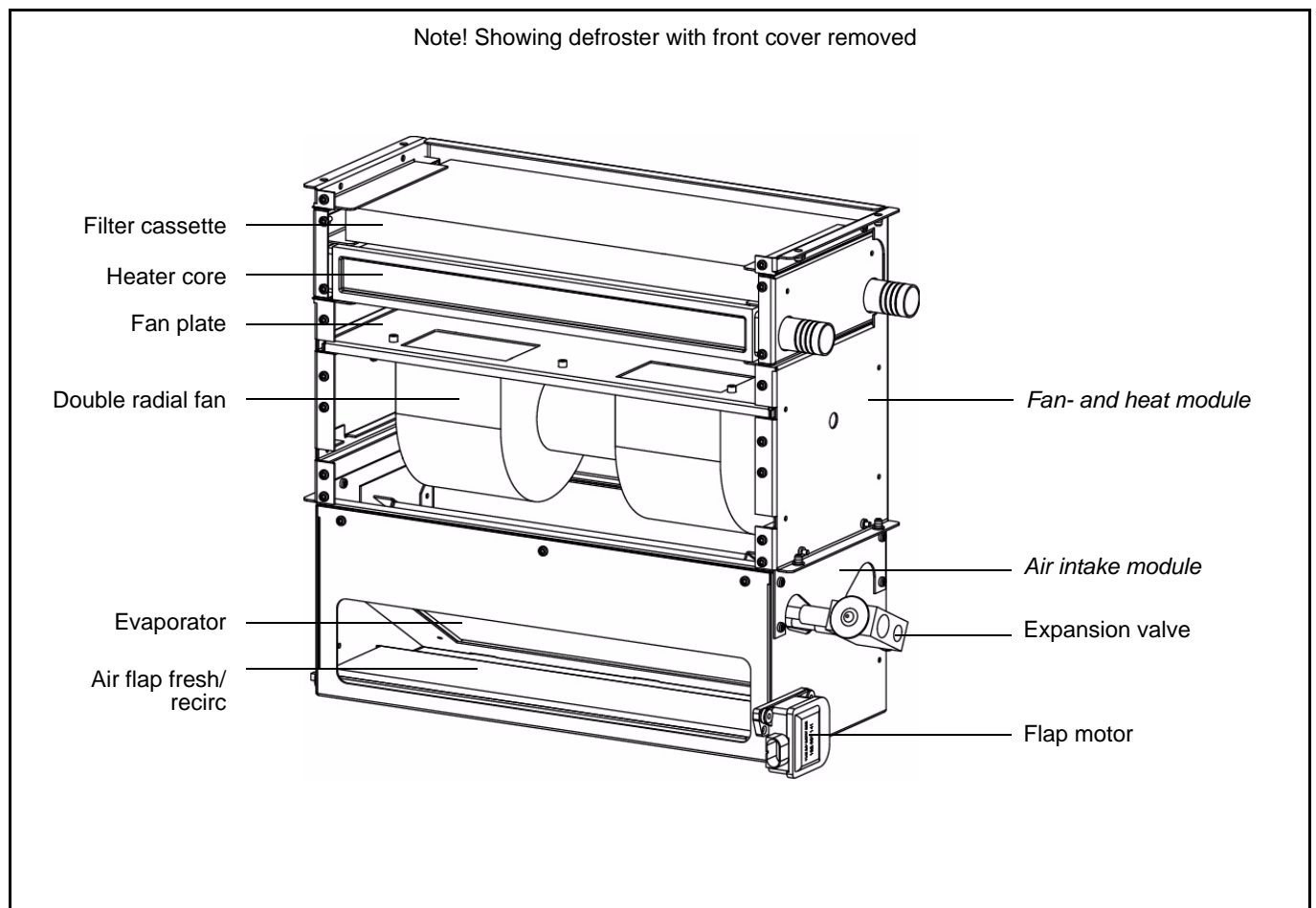

**Function**

The outside air is drawn through the double radial fan via the fresh/recirculated air intake. From the fan the air is led through the heating core and finally through the filter unit out to the defroster channels.

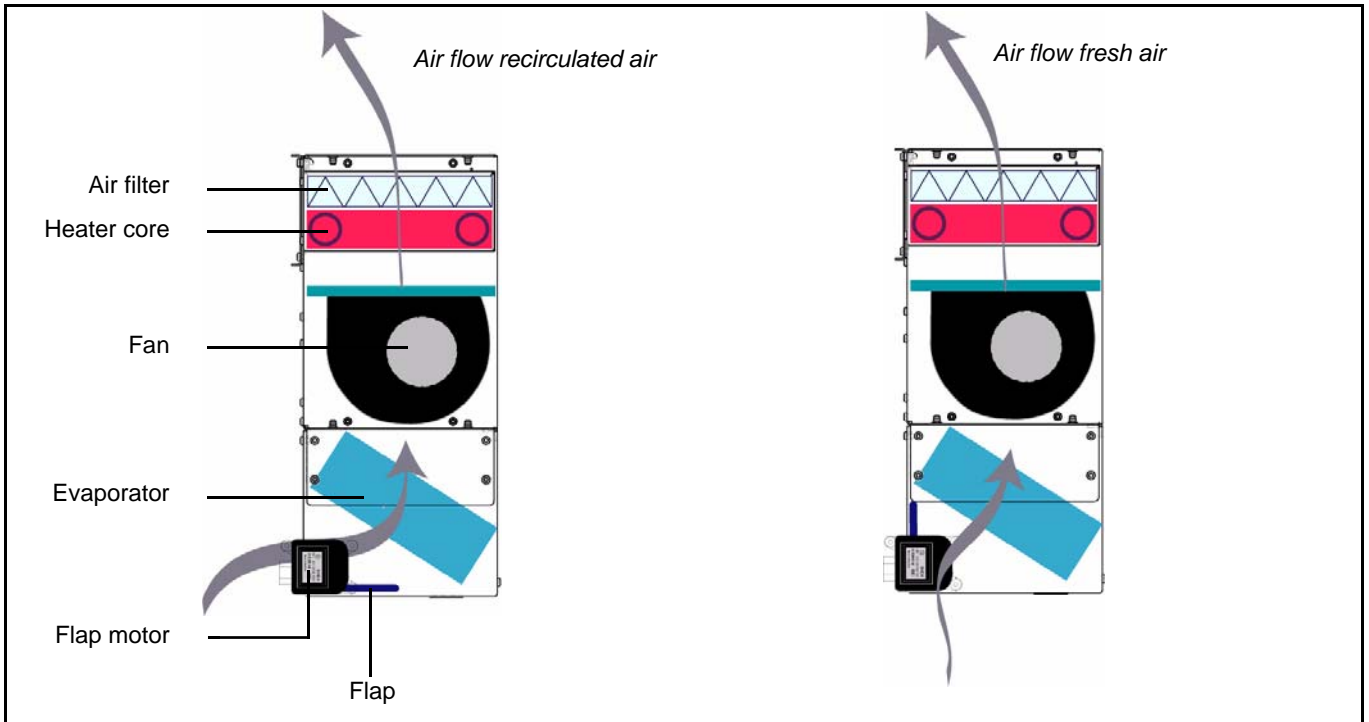

**Flexibility**

With the same parts, it is possible to change hose connections, filter before or after heater core, pressing or sucking fan etc. Some of these possibilities are shown below.

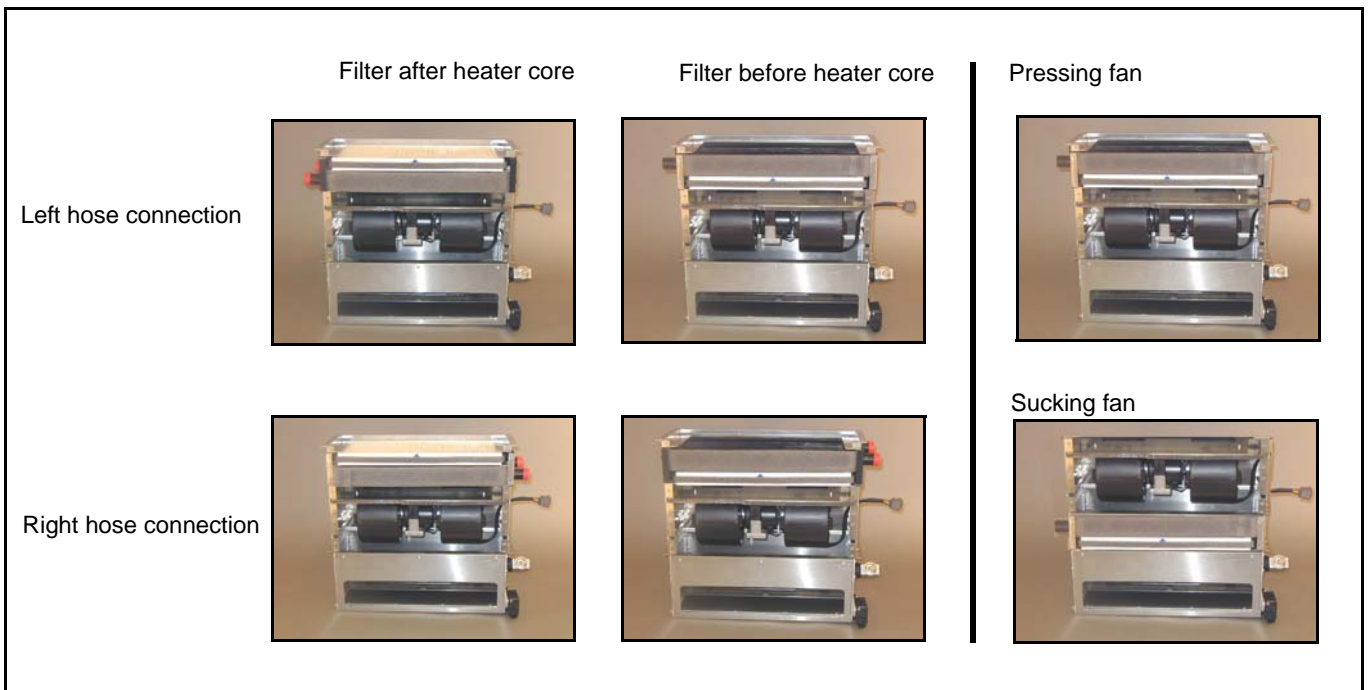

## Technical data

### Weights

Module	Part No.	Weight
Defroster (with AC)	15768	12.0 kg
Defroster (without AC)	15767	9,8 kg

### Electric characteristics

Current consumption, fan	max 15A	At 28V, air flow 870 m <sup>3</sup> /h
Current consumption, flap motor	max 250 mA	
Lifetime fan	longlife	
Protective class flap motor	IP50	

### Heat power

Speed	heat power (kW)
minimum	7 kW
medium	11 kW
maximum	16 kW

### Cooling capacity

The evaporator is dimensioned for 3kW cooling capacity

### Dimensions (mm)

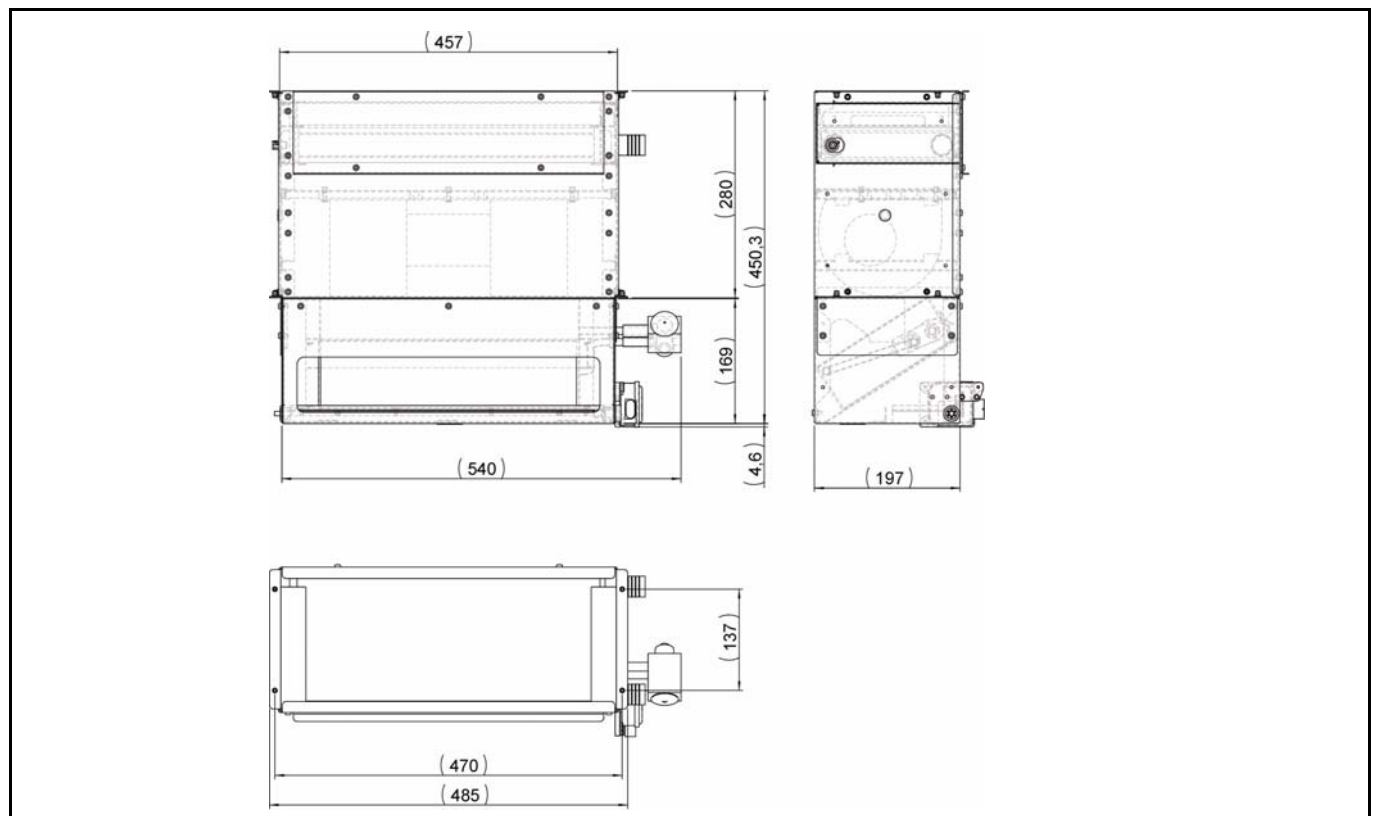

### Flow characteristics

Concern 24 V voltage, free flow defroster house with filter, but without any modules.

Speed	Air flow (no AC)	Current cons (no AC)	Air flow (AC)	Current cons (AC)
minimum	560 m <sup>3</sup> /h	5,7 A	460 m <sup>3</sup> /h	5,8 A
medium	680 m <sup>3</sup> /h	7,3 A	560 m <sup>3</sup> /h	7,3 A
maximum	870 m <sup>3</sup> /h	10,6 A	750 m <sup>3</sup> /h	10,5 A

### Connections

Connection defroster fan	Contact, male (house) Pins for male contact	Volvo 1259831 Volvo 968510
Connection flap motor	Contact, house Contact, pin	Bosch 1 928 403 095 AMP 962 885-1
Hose connection	Ø28	

### Materials

Upper and lower module	Aluminium	
Filter (see document Prd303)	Micro glass fibre paper	Efficiency: EU 5

---

**Product range**

---

IMPORTANT: When ordering Defroster Global, state with or without AC, water connection (left or right) and AC reffridgerant pipe connection (left or right).

**Defroster Global**

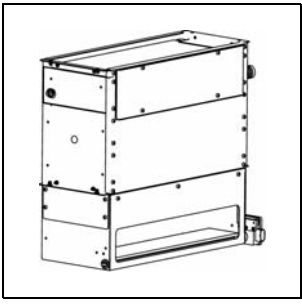
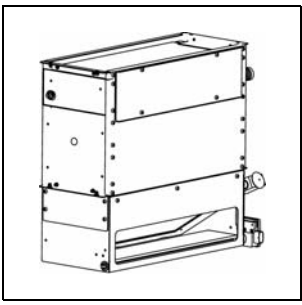
Description		Part No.
Complete Defroster Global, without AC. With air filter and pressing fan.		15767
Complete Defroster Global, with AC. With air filter and pressing fan.		15768

---

UWE Verken AB  
Box 262  
S-601 04 Norrköping, Sweden  
Phone +46 11 24 88 00  
Fax +46 11 12 47 04  
[www.uwe.se](http://www.uwe.se)

